



BY APPOINTMENT TO  
HER MAJESTY QUEEN ELIZABETH II  
MANUFACTURERS OF DAIMLER AND JAGUAR CARS  
JAGUAR CARS LIMITED COVENTRY



BY APPOINTMENT TO  
HER MAJESTY QUEEN ELIZABETH  
THE QUEEN MOTHER  
MANUFACTURERS OF DAIMLER AND JAGUAR CARS  
JAGUAR CARS LIMITED COVENTRY



BY APPOINTMENT TO  
HIS ROYAL HIGHNESS THE PRINCE OF WALES  
MANUFACTURERS OF DAIMLER AND JAGUAR CARS  
JAGUAR CARS LIMITED COVENTRY

# JAGUAR XK8

## 2000 Model Year XK8 Range Electrical Guide

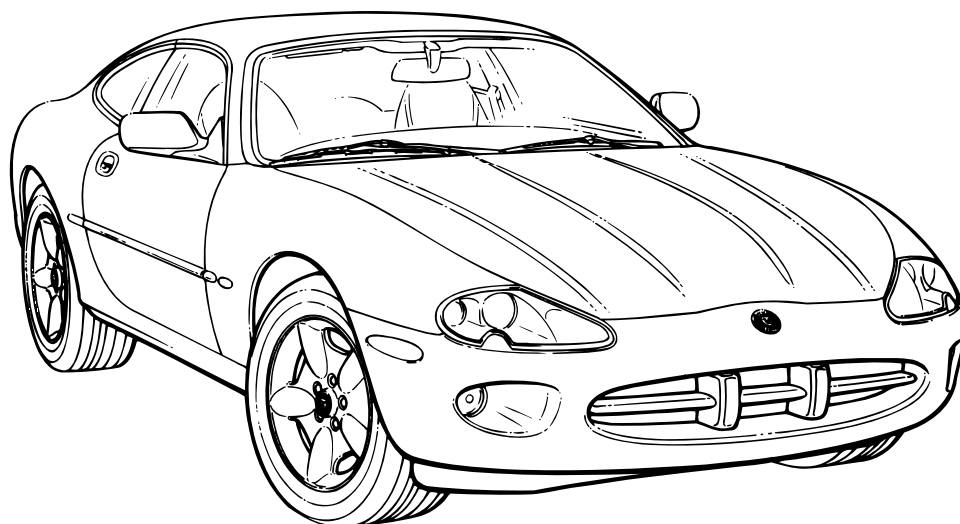

Published by Parts and Service Communications  
Jaguar Cars Limited

Publication Part Number – JTP 727





## Electrical Guide Format

This Electrical Guide is made up of two major sections. The first section, at the front of the book, provides general information for and about the use of the book, and information and illustrations to aid in the understanding of the XK8 electrical / electronic systems, as well as the location and identification of components.

The second section includes the Figures, which are the basis of the book. Each Figure is identified by a Figure Number (i.e. Fig. 01.1) and Title, and is accompanied by a page of data containing information specific to that Figure.

It is recommended that the user read through the front section of the book to develop a familiarity with the layout of the book and with the system of symbols and abbreviations used. The Table of Contents on the following pages should help to guide the user.

## Standard Abbreviations

The following abbreviations are used throughout this Electrical Guide:

B+	Battery Voltage
CAN	Controller Area Network
COUPE	Coupe Vehicles
CONV.	Convertible Vehicles
DI	Direction Indicator
LH	Left-Hand
LHD	Left-Hand Drive
N/A	Normally Aspirated
NAS	North American Specification
RH	Right-Hand
RHD	Right-Hand Drive
ROW	Rest of World
SC	Supercharged
SCP	Standard Corporate Protocol Network
VIN	Vehicle Identification Number

## Vehicle Identification Numbers (VIN)

VIN ranges are presented throughout the book in the following manner:

➔ VIN 123456 indicates "up to VIN 123456"; VIN 123456 ➔ indicates "from VIN 123456 on".

## XK8 Electrical System Architecture

The XK8 system "architecture" incorporates two data networks: a controller area network (CAN) for the engine, drive train and related systems, and a standard corporate protocol network (SCP) for the body systems. Any vehicle subsystem depicted on the figures with the CAN or SCP included uses data derived from the network, or transmits data via the network to achieve control. Messages for both networks are cataloged in the Appendix of this book. When appropriate, the user will be referred to the Appendix by a note on the Data page. In addition to the two networks, the XK8 uses a serial data bus (ISO) for diagnostics and for the programming of certain control modules.

The XK8 uses both power and logic grounds; however, it does not use a common logic ground stud connection as in previous vehicles.



Table of Contents: Figures .....	3 – 4
Component Index .....	5 – 9
User Instructions .....	10 – 11
Symbols and Codes .....	12 – 15
Connectors .....	16
Main Power Distribution .....	17
Harness Layout .....	18 – 19
Ground Point Location .....	20
Relay and Fuse Box Location .....	21
Control Module Location .....	22 – 23
Control Module Pin Identification .....	24 – 31
Electrical Guide Figures and Data .....	follows after page 31 (pages are numbered by Figure number)
Appendix (CAN and SCP messages) .....	follows Figures and Data



**FIGURES**

<b>Fig.</b>	<b>Description</b>	<b>Variant</b>
<b>01 Power Distribution</b>		
01.1	Main Power Distribution	All Vehicles
01.2	Battery Power Distribution: Driver and Passenger Fuse Boxes	All Vehicles
01.3	Battery Power Distribution: Trunk, Engine Compartment and EMS Fuse Boxes	All Vehicles
01.4	Ignition Switched Power Distribution	All Vehicles
01.5	Engine Management Switched Power Distribution	All Vehicles
<b>02 Ground Distribution</b>		
02.1	Ignition Switched Ground Distribution	All Vehicles
<b>03 Battery; Starter; Generator</b>		
03.1	Battery; Starter; Generator: AJ27 N/A	AJ27 N/A Vehicles
03.2	Battery; Starter; Generator: AJ27 SC	AJ27 SC Vehicles
<b>04 Engine Management</b>		
04.1	AJ27 N/A NAS Engine Management: Part 1	AJ27 N/A NAS Vehicles
04.2	AJ27 N/A ROW Engine Management: Part 1	AJ27 N/A ROW Vehicles
04.3	AJ27 N/A Engine Management: Part 2	AJ27 N/A Vehicles
04.4	AJ27 SC NAS Engine Management: Part 1	AJ27 SC NAS Vehicles
04.5	AJ27 SC ROW Engine Management: Part 1	AJ27 SC ROW Vehicles
04.6	AJ27 SC Engine Management: Part 2	AJ27 SC Vehicles
<b>05 Transmission</b>		
05.1	AJ27 N/A Automatic Transmission	AJ27 N/A Vehicles
05.2	AJ27 SC Automatic Transmission	AJ27 SC Vehicles
05.3	Gearshift Interlock	All Vehicles
<b>06 Chassis</b>		
06.1	Anti-Lock Braking; Traction Control	All Vehicles
06.2	Power Assisted Steering	All Vehicles
06.3	Suspension Adaptive Damping	Adaptive Damping Vehicles
06.4	Adaptive Speed Control	Adaptive Speed Control Vehicles
<b>07 Climate Control</b>		
07.1	Climate Control: Part 1	All Vehicles
07.2	Climate Control: Part 2	All Vehicles
<b>08 Instrumentation; Audible Warnings</b>		
08.1	Instrument Packs	All Vehicles
08.2	Audible Warnings	All Vehicles
<b>09 Exterior Lighting</b>		
09.1	Exterior Lighting: Front	All Vehicles
09.2	Exterior Lighting: Rear	All Vehicles
09.3	Headlamp Leveling	Headlamp Leveling Vehicles



## FIGURES

Fig.	Description	Variant
<b>10</b>	<b>Interior Lighting</b>	
10.1	Interior Lighting .....	All Vehicles
10.2	Dimmer-Controlled Lighting .....	All Vehicles
<b>11</b>	<b>Steering Column; Mirrors</b>	
11.1	Steering Column Movement .....	All Vehicles
11.2	Mirror Movement .....	All Vehicles
11.3	Interior and Exterior Mirrors; Fold-Back Mirrors .....	All Vehicles
<b>12</b>	<b>Seat Systems</b>	
12.1	Driver Seat: Memory .....	Memory Seat Vehicles
12.2	Driver Seat: Non Memory .....	Non Memory Seat Vehicles
12.3	Passenger Seat: 3-Way Movement .....	3-Way Movement Vehicles
12.4	Passenger Seat: 2-Way Movement .....	2-Way Movement Vehicles
<b>13</b>	<b>Door Locking</b>	
13.1	Central Door Locking .....	All Vehicles
<b>14</b>	<b>Wash / Wipe System</b>	
14.1	Wash / Wipe System .....	All Vehicles
<b>15</b>	<b>Window Lifts; Convertible Top</b>	
15.1	Window Lifts .....	All Vehicles
15.2	Convertible Top .....	Convertible Vehicles
<b>16</b>	<b>In-Car Entertainment</b>	
16.1	Standard In-Car Entertainment .....	Standard ICE Vehicles
16.2	Premium In-Car Entertainment .....	Premium ICE Vehicles
<b>17</b>	<b>Communications; Navigation</b>	
17.1	Telephone .....	All Vehicles
17.2	Navigation System .....	Navigation Only Vehicles
17.3	Navigation System with TV and VICS .....	TV and VICS Vehicles
<b>18</b>	<b>Supplementary Restraint System</b>	
18.1	Airbag System .....	All Vehicles
<b>19</b>	<b>Ancillaries</b>	
19.1	Ancillaries: Horns; Cigar Lighters; Accessory Connectors; Garage Door Opener .....	All Vehicles
<b>20</b>	<b>Vehicle Multiplex Systems</b>	
20.1	CAN (Network); SCP Network; Serial Data Links: AJ27 N/A .....	AJ27 N/A Vehicles
20.2	CAN (Network); SCP Network; Serial Data Links: AJ27 SC .....	AJ27 SC Vehicles



ABS / Traction Control Control Module .....	Fig. 06.1	Body Processor Module .....	Fig. 03.1
.....	Fig. 20.1	.....	Fig. 03.2
.....	Fig. 20.2	.....	Fig. 05.3
Accelerometers .....	Fig. 06.3	.....	Fig. 08.2
Active Security Sounder .....	Fig. 13.2	.....	Fig. 09.1
.....	Fig. 20.1	.....	Fig. 09.2
.....	Fig. 20.2	.....	Fig. 10.1
Adaptive Damping Control Module .....	Fig. 06.3	.....	Fig. 11.1
.....	Fig. 20.1	.....	Fig. 11.2
.....	Fig. 20.2	.....	Fig. 11.3
Adaptive Speed Control Booster Control Module .....	Fig. 06.4	.....	Fig. 12.1
.....	Fig. 20.2	.....	Fig. 12.2
.....		.....	Fig. 12.3
Adaptive Speed Control Brake Booster .....	Fig. 06.4	.....	Fig. 12.4
.....		.....	Fig. 13.1
Adaptive Speed Control Control Module .....	Fig. 06.4	.....	Fig. 13.2
.....	Fig. 20.2	.....	Fig. 13.3
.....		.....	Fig. 14.1
Adaptive Speed Control Master Switch .....	Fig. 06.4	.....	Fig. 15.1
.....		.....	Fig. 15.2
Air Assist Close Valve .....	Fig. 04.1	.....	Fig. 19.1
.....	Fig. 04.2	.....	Fig. 20.1
.....		.....	Fig. 20.2
Air Conditioning Compressor Clutch .....	Fig. 04.3	Brake Booster Pressure Sensors .....	Fig. 06.4
.....	Fig. 04.6	Brake Cancel Switch .....	Fig. 04.3
.....	Fig. 07.2	.....	Fig. 04.6
Air Conditioning Control Module .....	Fig. 04.3	.....	Fig. 06.4
.....	Fig. 04.6	Brake Fluid Reservoir .....	Fig. 06.1
.....	Fig. 07.1	Brake Switch .....	Fig. 04.1
.....	Fig. 07.2	.....	Fig. 04.2
.....	Fig. 20.1	.....	Fig. 04.4
.....	Fig. 20.2	.....	Fig. 04.5
Air Conditioning Control Panel .....	Fig. 07.1	.....	Fig. 05.3
.....	Fig. 10.2	.....	Fig. 06.1
Air Intake – LH & RH Blower .....	Fig. 07.1	.....	Fig. 06.3
Airbag / SRS Control Module .....	Fig. 18.1	.....	Fig. 09.2
.....	Fig. 20.1	Canister Close Valve (CCV) .....	Fig. 04.1
.....	Fig. 20.2	.....	Fig. 04.4
Airbag Interrogation Connector .....	Fig. 18.1	CD Auto-Changer .....	Fig. 16.1
Airbag – Driver Side (Steering Wheel) .....	Fig. 18.1	.....	Fig. 16.2
.....		.....	Fig. 17.2
Airbag – Passenger Side .....	Fig. 18.1	Cellular Telephone Control Module .....	Fig. 17.1
Ambient Temperature Sensor .....	Fig. 07.1	Center Console Switch Pack .....	Fig. 09.1
Antenna Motor .....	Fig. 16.1	.....	Fig. 09.2
.....	Fig. 16.2	.....	Fig. 10.2
Aspirator Assembly .....	Fig. 07.1	Cigar Lighter .....	Fig. 10.2
Audible Warning Speaker (Column Switchgear) .....	Fig. 08.2	.....	Fig. 19.1
Auto Tilt Switch (Column Switchgear) .....	Fig. 11.1	Crankshaft Position Sensor (CKPS) .....	Fig. 04.1
Battery .....	Fig. 03.1	.....	Fig. 04.2
.....	Fig. 03.2	.....	Fig. 04.4
Blower Motors .....	Fig. 07.2	.....	Fig. 04.5
		Camshaft Position Sensors (CMPS) .....	Fig. 04.1
		.....	Fig. 04.2
		.....	Fig. 04.4
		.....	Fig. 04.5
		Column Joy Stick (Column Switchgear) .....	Fig. 11.1
		Convertible Top Closed Switch .....	Fig. 15.2
		Convertible Top Down Switch .....	Fig. 15.2
		Convertible Top Latch Closed Switch .....	Fig. 15.2
		Convertible Top Pump .....	Fig. 15.2
		Convertible Top Raised Switch .....	Fig. 15.2



Convertible Top Ready-To-Latch Switch .....	Fig. 15.2	ECM and TCM Cooling Fan .....	Fig. 04.1
Convertible Top Switch .....	Fig. 10.2	.....	Fig. 04.2
.....	Fig. 15.2	.....	Fig. 04.4
Coolant Level Switch .....	Fig. 08.1	.....	Fig. 04.5
D – 4 Switch .....	Fig. 05.1	Engine Coolant Temperature Sensor (ECTS) .....	Fig. 04.1
Damper Solenoids .....	Fig. 06.3	.....	Fig. 04.2
Data Link Connector .....	Fig. 20.1	.....	Fig. 04.4
.....	Fig. 20.2	.....	Fig. 04.5
Dimmer Control (Column Switchgear) .....	Fig. 10.2	EGR Valve .....	Fig. 04.4
Dimmer Module .....	Fig. 10.2	Engine Compartment Security Switch .....	Fig. 13.2
Diode (BT29) – Trunk Switch .....	Fig. 10.1	.....	Fig. 13.3
Door Control Module – Driver .....	Fig. 10.1	Engine Control Module .....	Fig. 03.1
.....	Fig. 11.1	.....	Fig. 03.2
.....	Fig. 11.2	.....	Fig. 04.1
.....	Fig. 11.3	.....	Fig. 04.2
.....	Fig. 12.1	.....	Fig. 04.3
.....	Fig. 13.1	.....	Fig. 04.4
.....	Fig. 13.2	.....	Fig. 04.5
.....	Fig. 13.3	.....	Fig. 04.6
.....	Fig. 15.1	.....	Fig. 05.3
.....	Fig. 15.2	.....	Fig. 06.4
.....	Fig. 20.1	.....	Fig. 07.2
.....	Fig. 20.2	.....	Fig. 13.2
Door Control Module – Passenger .....	Fig. 10.1	.....	Fig. 13.3
.....	Fig. 11.2	.....	Fig. 20.1
.....	Fig. 13.1	.....	Fig. 20.2
.....	Fig. 13.2	Engine Oil Temperature Sensor (EOTS) .....	Fig. 04.1
.....	Fig. 13.3	.....	Fig. 04.2
.....	Fig. 15.1	.....	Fig. 04.4
.....	Fig. 15.2	.....	Fig. 04.5
.....	Fig. 20.1	Evaporator / Heater Matrix Assembly .....	Fig. 07.1
.....	Fig. 20.2	Evaporative Emission Control Valve (EVAPP) .....	Fig. 04.1
Door Lock Actuator – Driver .....	Fig. 13.1	.....	Fig. 04.2
Door Lock Actuator – Passenger .....	Fig. 13.1	.....	Fig. 04.4
Door Lock Switch – Passenger .....	Fig. 13.1	.....	Fig. 04.5
Door Lock Switches – Driver .....	Fig. 10.1	Fascia Accessory Connector .....	Fig. 19.1
.....	Fig. 13.1	Footwell Lamps .....	Fig. 10.1
.....	Fig. 13.2	Front Fog Lamps .....	Fig. 09.1
.....	Fig. 13.3	Front Lamp Units .....	Fig. 09.1
.....	Fig. 15.1	Front Side Markers (NAS only) .....	Fig. 09.1
Door Mirror Motors – Driver .....	Fig. 11.2	Fuel Tank Pressure Sensor (FTPS) .....	Fig. 04.1
Door Mirror Motors – Passenger .....	Fig. 11.2	.....	Fig. 04.4
Door Mirror – Driver .....	Fig. 11.3	Fuel Fill Flap Solenoid .....	Fig. 13.1
Door Mirror – Passenger .....	Fig. 11.3	Fuel Injectors .....	Fig. 04.3
Door Switch – Driver .....	Fig. 10.1	.....	Fig. 04.6
.....	Fig. 11.1	Fuel Level Sensor .....	Fig. 08.1
.....	Fig. 11.2	Fuel Pump .....	Fig. 04.3
.....	Fig. 13.1	Fuel Pumps .....	Fig. 04.6
.....	Fig. 13.2	Fuse Box – Driver Side .....	Fig. 01.2
.....	Fig. 13.3	.....	Fig. 01.4
Door Switch – Passenger .....	Fig. 10.1	Fuse Box – Engine Compartment .....	Fig. 01.3
.....	Fig. 13.1	.....	Fig. 01.4
.....	Fig. 13.2	.....	Fig. 07.2
.....	Fig. 13.3	.....	Fig. 09.1
Dual Linear Switch .....	Fig. 03.2	.....	Fig. 13.2
.....	Fig. 05.2	.....	Fig. 13.3
		.....	Fig. 14.1
		.....	Fig. 19.1



Fuse Box – Engine Management .....	Fig. 01.3	Key Fob Antenna .....	Fig. 13.1
.....	Fig. 01.5	.....	Fig. 13.2
Fuse Box – Passenger Side .....	Fig. 01.2	.....	Fig. 13.3
.....	Fig. 01.4	Key Transponder Module .....	Fig. 03.1
Fuse Box – Trunk .....	Fig. 01.3	.....	Fig. 03.2
.....	Fig. 01.4	.....	Fig. 13.2
.....	Fig. 04.3	.....	Fig. 13.3
.....	Fig. 04.6	.....	Fig. 20.1
.....	Fig. 07.2	.....	Fig. 20.2
.....	Fig. 09.2	Keylock Solenoid (Column Switchgear) .....	Fig. 05.3
.....	Fig. 19.1	Kickdown Switch .....	Fig. 05.2
Garage Door Opener (Roof Console) .....	Fig. 19.1	Knock Sensors (KS) .....	Fig. 04.1
Gear Selector Illumination Module .....	Fig. 05.1	.....	Fig. 04.2
.....	Fig. 05.2	.....	Fig. 04.4
.....	Fig. 05.3	.....	Fig. 04.5
.....	Fig. 10.2	Lamp Control Module .....	Fig. 09.2
.....	Fig. 20.1	Latch Control Valve .....	Fig. 15.2
.....	Fig. 20.2	Leveling Switch (Center Console Switch Pack) .....	Fig. 09.3
Gearshift Interlock Solenoid .....	Fig. 05.3	Lighting Stalk (Column Switchgear) .....	Fig. 09.1
Generator .....	Fig. 03.1	.....	Fig. 09.2
Glass Breakage Sensor (Roof Console) .....	Fig. 13.2	.....	Fig. 10.2
Glove Box Lamp .....	Fig. 10.1	.....	Fig. 11.3
Handset .....	Fig. 17.1	.....	Fig. 14.1
Headlamp Leveling Actuators .....	Fig. 09.3	Mass Air Flow Sensor (MAFS) .....	Fig. 04.1
Heated Backlight .....	Fig. 07.2	.....	Fig. 04.2
Heater Pump .....	Fig. 07.2	.....	Fig. 04.4
Heater Valve .....	Fig. 07.2	.....	Fig. 04.5
High Mount Stop Lamp .....	Fig. 09.2	Main Control Valve .....	Fig. 15.2
High Power Protection Module .....	Fig. 03.1	Major Instrument Pack .....	Fig. 05.3
.....	Fig. 03.2	.....	Fig. 08.1
Heated Oxygen Sensors (HO2S) .....	Fig. 04.1	.....	Fig. 09.1
.....	Fig. 04.2	.....	Fig. 09.2
.....	Fig. 04.4	.....	Fig. 10.2
.....	Fig. 04.5	.....	Fig. 11.2
Horn Switches (Steering Wheel) .....	Fig. 19.1	.....	Fig. 11.3
Horns .....	Fig. 13.2	.....	Fig. 12.1
.....	Fig. 13.3	.....	Fig. 13.2
.....	Fig. 19.1	.....	Fig. 13.3
Intake Air Temperature Sensor 2 (IATS 2) .....	Fig. 04.4	.....	Fig. 15.1
.....	Fig. 04.5	.....	Fig. 15.2
Ignition Coils .....	Fig. 04.3	.....	Fig. 16.1
.....	Fig. 04.6	.....	Fig. 16.2
Ignition Switch (Key-In Switch) .....	Fig. 02.1	.....	Fig. 20.1
.....	Fig. 03.1	.....	Fig. 20.2
.....	Fig. 03.2	Manifold Absolute Pressure Sensor (MAPS) .....	Fig. 04.4
.....	Fig. 10.1	Microphone .....	Fig. 17.1
.....	Fig. 11.1	Minor Instrument Pack .....	Fig. 08.1
.....	Fig. 13.1	.....	Fig. 10.2
Impact Sensors .....	Fig. 18.1	Mirror Joy Stick (Driver Door Switch Pack) .....	Fig. 11.3
Inclination Sensor .....	Fig. 13.2	.....	Fig. 11.2
Inertia Switch .....	Fig. 02.1	Mirrors .....	Fig. 07.2
Intercooler Pump .....	Fig. 04.6	Mode Switch (Transmission) .....	Fig. 05.1
Interior Rear View Mirror .....	Fig. 11.3	.....	Fig. 05.2
.....	Fig. 14.1	.....	Fig. 10.2
		Navigation Control Module .....	Fig. 10.2
		.....	Fig. 17.2
		.....	Fig. 17.3
		Navigation Display .....	Fig. 10.2
		.....	Fig. 17.2
		.....	Fig. 17.3





Navigation GPS Antenna .....	Fig. 17.2	Regulator (Generator) .....	Fig. 03.1
.....	Fig. 17.3	.....	Fig. 03.2
Neutral Switch .....	Fig. 03.1	Roof Console .....	Fig. 10.1
Not-In-Park Microswitch .....	Fig. 05.3	.....	Fig. 13.3
.....	Fig. 11.1	Seat Belt Pre-Tensioners .....	Fig. 18.1
.....	Fig. 11.2	Seat Belt Switch .....	Fig. 12.1
.....	Fig. 13.1	.....	Fig. 12.2
Number Plate Lamps .....	Fig. 09.2	.....	Fig. 12.3
Oxygen Sensors (O2S) .....	Fig. 04.1	Seat Control Module – Driver .....	Fig. 11.3
.....	Fig. 04.2	.....	Fig. 12.1
Oil Pressure Switch .....	Fig. 08.1	.....	Fig. 12.2
Parking Brake Switch .....	Fig. 04.1	.....	Fig. 20.1
.....	Fig. 04.2	.....	Fig. 20.2
.....	Fig. 17.3	Seat Control Module – Passenger .....	Fig. 11.3
Passive Security Sounder .....	Fig. 13.2	.....	Fig. 12.3
.....	Fig. 13.3	.....	Fig. 12.4
Power Amplifier .....	Fig. 16.2	.....	Fig. 20.1
.....	Fig. 17.2	.....	Fig. 20.2
.....	Fig. 17.3	Seat Cushion (Heater) – Driver .....	Fig. 12.1
Power Assisted Steering Control Module .....	Fig. 06.2	.....	Fig. 12.2
Powerwash Pump .....	Fig. 14.1	Seat Cushion (Heater) – Passenger .....	Fig. 12.3
Pedal Position Sensors (PPS) .....	Fig. 04.1	.....	Fig. 12.4
.....	Fig. 04.2	Seat Heater Switch (Center Console Switch Pack) .....	Fig. 12.1
.....	Fig. 04.4	.....	Fig. 12.2
.....	Fig. 04.5	.....	Fig. 12.3
Pre-Tensioner Control Module .....	Fig. 18.1	.....	Fig. 12.4
Puddle Lamps .....	Fig. 10.1	Seat Lumbar Pump – Driver .....	Fig. 12.1
Quarter Light Lifts .....	Fig. 15.2	.....	Fig. 12.2
Radiator Fan Control Relay Module .....	Fig. 04.3	.....	Fig. 12.3
.....	Fig. 04.6	.....	Fig. 12.4
.....	Fig. 07.2	Seat Lumbar Pump – Passenger .....	Fig. 12.3
Radiator Fans .....	Fig. 04.3	Seat Motors – Driver .....	Fig. 12.1
.....	Fig. 04.6	.....	Fig. 12.2
.....	Fig. 07.2	Seat Motors – Passenger .....	Fig. 12.3
Radio / Cassette Head Unit .....	Fig. 10.2	.....	Fig. 12.4
.....	Fig. 16.1	Security Active Indicator .....	Fig. 13.2
.....	Fig. 16.2	.....	Fig. 13.3
.....	Fig. 17.2	Security and Locking Control Module .....	Fig. 09.2
.....	Fig. 17.3	.....	Fig. 11.3
Vehicle Speed Interface Module .....	Fig. 17.2	.....	Fig. 13.1
Radio / Cassette Head Unit .....	Fig. 17.3	.....	Fig. 13.2
Radio Antenna .....	Fig. 16.1	.....	Fig. 13.3
.....	Fig. 16.2	.....	Fig. 15.1
Radio Control Switches (Steering Wheel) .....	Fig. 16.1	.....	Fig. 15.2
.....	Fig. 16.2	.....	Fig. 20.1
Rain Sensing Module .....	Fig. 14.1	.....	Fig. 20.2
Rain Sensor .....	Fig. 14.1	Side DI Repeaters (ROW) .....	Fig. 09.1
Reader / Exciter Coil (Column Switchgear) .....	Fig. 13.2	Solar Sensor .....	Fig. 07.1
.....	Fig. 13.3	Speakers – Mid-Bass .....	Fig. 16.1
Rear Interior Lamp (Coupe Only) .....	Fig. 10.1	.....	Fig. 16.2
Rear Side Markers (NAS Only) .....	Fig. 09.2	Speakers – Tweeter .....	Fig. 16.2
Refrigerant 4-Way Pressure Switch .....	Fig. 04.3	Speakers – Fascia .....	Fig. 16.1
.....	Fig. 04.6	.....	Fig. 16.2
.....	Fig. 07.2	Speakers – Rear (Convertible) .....	Fig. 16.1
Regulator (Generator) .....	Fig. 03.1	.....	Fig. 16.2
.....	Fig. 03.2	Speakers – Rear Quarter .....	Fig. 16.1
Roof Console .....	Fig. 10.1	.....	Fig. 16.2
.....	Fig. 13.3	Speaker – Rear (Coupe) .....	Fig. 16.2
Seat Belt Pre-Tensioners .....	Fig. 18.1		
Seat Belt Switch .....	Fig. 12.1		
.....	Fig. 12.2		
.....	Fig. 12.3		
Seat Control Module – Driver .....	Fig. 11.3		
.....	Fig. 12.1		
.....	Fig. 12.2		
.....	Fig. 20.1		
.....	Fig. 20.2		
Seat Control Module – Passenger .....	Fig. 11.3		
.....	Fig. 12.3		
.....	Fig. 12.4		
.....	Fig. 20.1		
.....	Fig. 20.2		
Seat Cushion (Heater) – Driver .....	Fig. 12.1		
.....	Fig. 12.2		
Seat Cushion (Heater) – Passenger .....	Fig. 12.3		
.....	Fig. 12.4		
Seat Heater Switch (Center Console Switch Pack) .....	Fig. 12.1		
.....	Fig. 12.2		
.....	Fig. 12.3		
.....	Fig. 12.4		
Seat Lumbar Pump – Driver .....	Fig. 12.1		
.....	Fig. 12.2		
Seat Lumbar Pump – Passenger .....	Fig. 12.3		
Seat Motors – Driver .....	Fig. 12.1		
.....	Fig. 12.2		
Seat Motors – Passenger .....	Fig. 12.3		
.....	Fig. 12.4		
Security Active Indicator .....	Fig. 13.2		
.....	Fig. 13.3		
Security and Locking Control Module .....	Fig. 09.2		
.....	Fig. 11.3		
.....	Fig. 13.1		
.....	Fig. 13.2		
.....	Fig. 13.3		
.....	Fig. 15.1		
.....	Fig. 15.2		
.....	Fig. 20.1		
.....	Fig. 20.2		
Side DI Repeaters (ROW) .....	Fig. 09.1		
Solar Sensor .....	Fig. 07.1		
Speakers – Mid-Bass .....	Fig. 16.1		
.....	Fig. 16.2		
Speakers – Tweeter .....	Fig. 16.2		
Speakers – Fascia .....	Fig. 16.1		
.....	Fig. 16.2		
Speakers – Rear (Convertible) .....	Fig. 16.1		
.....	Fig. 16.2		
Speakers – Rear Quarter .....	Fig. 16.1		
.....	Fig. 16.2		
Speaker – Rear (Coupe) .....	Fig. 16.2		



Speed Control On / Off Switch .....	Fig. 04.3	Trunk Switch .....	Fig. 10.1
.....	Fig. 04.6	.....	Fig. 13.1
.....	Fig. 10.2	.....	Fig. 13.2
.....		.....	Fig. 13.3
Speed Control Switches (Steering Wheel) .....	Fig. 04.3	Valet Switch .....	Fig. 10.2
.....	Fig. 04.6	.....	Fig. 13.1
.....	Fig. 06.4	.....	Fig. 13.2
.....		.....	Fig. 13.3
Squab (Heater) – Driver .....	Fig. 12.1	Vanity Lamps .....	Fig. 10.1
.....	Fig. 12.2	Variable Steering Converter .....	Fig. 06.2
Squab (Heater) – Passenger .....	Fig. 12.3	Vehicle Information Control Beacon Module .....	Fig. 17.3
.....	Fig. 12.4	Vehicle Information Control Infrared Sensor .....	Fig. 17.3
Stability / Traction Control Switch .....	Fig. 06.1	Vehicle Information Control Module .....	Fig. 17.3
Starter Motor .....	Fig. 03.1	Vehicle Speed Interface Module .....	Fig. 17.3
.....	Fig. 03.2	.....	Fig. 20.1
Steering Column Motors .....	Fig. 11.1	.....	Fig. 20.2
Suppression Module .....	Fig. 03.1	Vent Assembly .....	Fig. 07.1
.....	Fig. 03.2	Variable Valve Timing Solenoid Valves (VVT Solenoid Valves) ..	Fig. 04.1
Switch Pack – Driver Door .....	Fig. 10.2	.....	Fig. 04.2
Switch Pack – Driver Door Memory .....	Fig. 10.2	Wash / Wipe Stalk (Column Switchgear) .....	Fig. 14.1
.....	Fig. 11.1	Wheel Speed Sensors .....	Fig. 06.1
.....	Fig. 11.2	Window Lift Switches – Driver Door .....	Fig. 15.1
.....	Fig. 12.1	Window Lift Switches – Passenger Door .....	Fig. 15.1
Switch Pack – Driver Seat .....	Fig. 12.1	Window Lift – Driver .....	Fig. 15.1
.....	Fig. 12.2	Window Lift – Passenger .....	Fig. 15.1
Switch Pack – Passenger Door .....	Fig. 10.2	Windshield Heaters .....	Fig. 07.2
Switch Pack – Passenger Seat .....	Fig. 12.3	Windshield Wash Pump and Fluid Level Sensor .....	Fig. 14.1
.....	Fig. 12.4	Wiper Motor .....	Fig. 14.1
Tail Lamp Units .....	Fig. 09.2		
Telephone Antenna .....	Fig. 17.1		
Television Antenna Amplifier .....	Fig. 17.3		
Television Antennas .....	Fig. 17.3		
Television Module .....	Fig. 17.3		
Throttle Motor .....	Fig. 04.1		
.....	Fig. 04.2		
.....	Fig. 04.4		
.....	Fig. 04.5		
Throttle Position Sensors (TPS) .....	Fig. 04.1		
.....	Fig. 04.2		
.....	Fig. 04.4		
.....	Fig. 04.5		
Transmission Control Module: AJ27 N/A .....	Fig. 05.1		
.....	Fig. 20.1		
.....	Fig. 20.2		
Transmission Control Module: AJ27 SC .....	Fig. 05.2		
.....	Fig. 20.1		
.....	Fig. 20.2		
Transmission Rotary Switch .....	Fig. 05.1		
Trip Computer Switch Pack .....	Fig. 08.1		
.....	Fig. 10.2		
Trip Cycle Switch (Column Switchgear) .....	Fig. 08.1		
Trunk Accessory Connector .....	Fig. 19.1		
Trunk and Fuel Fill Release Switch .....	Fig. 10.2		
.....	Fig. 13.1		
Trunk Lamps .....	Fig. 10.1		
Trunk Release Solenoid .....	Fig. 13.1		



## Figure and Data Page Layout

### Figure Pages

Each Figure represents a specific electrical system of the vehicle. The Figures are arranged numerically by system (**01 – Power Distribution**, **02 – Ground Distribution**, etc.) with variations in the system identified by a numeral following a decimal point (**01.1**, **01.2**, etc.). Refer to the Table of Contents for a complete list of the Figures.

The Figures **01 – Power Distribution** detail the distribution of power to each of the systems. Numbered reference symbols refer the user to a specific Figure and from a specific Figure back to the Power Distribution Figures. This method eliminates the need to include detailed Power Distribution information on each of the Figures. Similarly, the Figure **02 – Ground Distribution** details the ignition switched ground distribution. The reference symbols are defined on page 12.

Each Figure appears on a right-hand page with a corresponding Data page to the left. The Figure and Data pages are folding pages. The user must fold out both pages in order to access all the information provided.

### Data Pages

The Data page includes information to assist the user in identifying and locating components, connectors and grounds. This information is supplemented by the illustrations in this front section of the book.

When network data is required for the understanding of a particular circuit, the user is directed to the Appendix.

Where circuits include a Control Module, Pin Out information is provided with values for “active” and “inactive” states. The values listed are approximately those that can be expected at the control module connector pins with all circuit connections made and all components connected and fitted. “Active” means a load is applied or a switch is ON; “inactive” means a load is not applied or a switch is OFF. This information is provided to assist the user in understanding circuit operation and should be used FOR REFERENCE ONLY.



## CONTROL MODULE PIN OUT INFORMATION

## FIGURE NUMBER

## COMPONENT, RELAY, CONNECTOR AND GROUND INFORMATION

**CONTROL MODULE PIN OUT INFORMATION**

**BODY PROCESSOR MODULE**

Pin	Description	Active	Inactive
FCB-1	MULTI-SENSOR LEADS	GROUND (B)	B- (4, 5, 1, 2)
FCB-2	SECURITY TRANSMITTER	GROUND (COMMON)	B-
FCB-3	STARTER SOLAR RELAY	GROUND (COMMON)	B-
FCB-4	CONTROL SIGNAL ACTIVITY	GROUND (COMMON)	B-
FCB-5	BATTERY SUPPLY VOLTAGE	B+	B-
FCB-6	SECURITY COMMUNICATIONS		

**ENGINE CONTROL MODULE**

Pin	Description	Active	Inactive
EMU-1	IMM. SIGNAL CONFIRMATION	B+ (B)	GROUND (COMMON)
EMU-2	IMM. SIGNAL	GROUND (COMMON)	GROUND (COMMON)
EMU-3	IC TO START	GROUND (COMMON)	GROUND (COMMON)
EMU-4	SECURITY ACKNOWLEDGE	GROUND (COMMON)	GROUND (COMMON)

**KEY TRANSMITTER MODULE**

Pin	Description	Active	Inactive
FKB-1	GROUND (COMMON)		
FKB-2	GROUND (COMMON)		
FKB-3	GROUND (COMMON)		
FKB-4	GROUND (COMMON)		

**Fig. 03.1**

Component	Connector / Type / Color	Location / Access
BATTERY	B741 (E) LEFT B742 (E) RIGHT	TRUNK, RIGHT HAND SIDE
BODY PROCESSOR MODULE	B741 (E) LEFT B742 (E) RIGHT	TRUNK, RIGHT HAND SIDE
ENGINE CONTROL MODULE	EMU-1 (E) 20-WAY AMP (RED) / NATURAL EMU-2 (E) 20-WAY AMP (RED) / NATURAL EMU-3 (E) 20-WAY AMP (RED) / NATURAL EMU-4 (E) 20-WAY AMP (RED) / NATURAL EMU-5 (E) 20-WAY AMP (RED) / NATURAL EMU-6 (E) 20-WAY AMP (RED) / NATURAL	ENGINE COMPARTMENT / CONTROL MODULE ENCLOSURE
GENERATOR	GEN-1 (E) LEFT GEN-2 (E) RIGHT	ENGINE COMPARTMENT / RIGHT FRONT
HIGH POWER PROTECTION MODULE	HPP-1 (E) LEFT HPP-2 (E) RIGHT	TRUNK / ADJACENT TO BATTERY
IGNITION SWITCH (KEY IN SWITCH)	ISW-1 (E) LEFT ISW-2 (E) RIGHT	STEERING COLUMN
KEY TRANSMITTER MODULE	FKB-1 (E) 20-WAY MULTICOLORED (RED) / WHITE FKB-2 (E) 20-WAY MULTICOLORED (RED) / GREEN FKB-3 (E) 20-WAY MULTICOLORED (RED) / GREEN FKB-4 (E) 20-WAY MULTICOLORED (RED) / BLACK	ADJACENT TO DRIVER SIDE FUSE BOX GEAR SELECTOR ASSEMBLY ENGINE COMPARTMENT / GENERATOR
REGULATOR (GENERATOR)	REG-1 (E) LEFT REG-2 (E) RIGHT	ENGINE COMPARTMENT / RIGHT FRONT
STARTER MOTOR	SM-1 (E) LEFT SM-2 (E) RIGHT	TRUNK BLOCK
SUPPRESSION MODULE	SM-1 (E) LEFT SM-2 (E) RIGHT	REARWARD OF RIGHT FRONT HEADLAMP

Relay	Color / Strips	Connector / Color	Location / Access
STARTER RELAY	BROWN	DN12 / BROWN	EN-1 ENCLOSURE RELAYS

Connector	Type / Color	Location / Access
B741	(E) LEFT	ENGINE COMPARTMENT / FALSE BELLYHEAD, RIGHT HAND SIDE
B742	(E) RIGHT	ENGINE COMPARTMENT / ADJACENT TO RIGHT HAND ENCLOSURE
EMU-1	20-WAY MULTICOLORED (RED) / WHITE	ENGINE COMPARTMENT / ADJACENT TO RIGHT HAND ENCLOSURE
EMU-2	20-WAY MULTICOLORED (RED) / GREEN	ENGINE COMPARTMENT / ADJACENT TO RIGHT HAND ENCLOSURE
EMU-3	20-WAY MULTICOLORED (RED) / GREEN	ENGINE COMPARTMENT / ADJACENT TO RIGHT HAND ENCLOSURE
EMU-4	20-WAY MULTICOLORED (RED) / BLACK	ENGINE COMPARTMENT / REARWARD OF ENGINE/KEY AREA
EMU-5	20-WAY MULTICOLORED (RED) / BLACK	ENGINE COMPARTMENT / ADJACENT TO TOP OF TRANSMISSION
EMU-6	20-WAY MULTICOLORED (RED) / RED	ENGINE COMPARTMENT / FALSE BELLYHEAD, RIGHT HAND SIDE

Ground	Location / Type
B741	TRUNK, RIGHT HAND SIDE
B742	TRUNK, RIGHT HAND SIDE
EMU-1	ENGINE COMPARTMENT / FALSE BELLYHEAD, RIGHT HAND SIDE
EMU-2	ENGINE COMPARTMENT / ADJACENT TO RIGHT HAND ENCLOSURE
EMU-3	ENGINE COMPARTMENT / ADJACENT TO RIGHT HAND ENCLOSURE
EMU-4	ENGINE COMPARTMENT / REARWARD OF ENGINE/KEY AREA
EMU-5	ENGINE COMPARTMENT / ADJACENT TO TOP OF TRANSMISSION
EMU-6	ENGINE COMPARTMENT / FALSE BELLYHEAD, RIGHT HAND SIDE

FOR CONTROL MODULE PIN OUT INFORMATION, UNFOLD PAGE TO LEFT.

The following abbreviations are used to represent values for Control Module Pin-Out data:

I	Input	D	Serial and Encoded Data	BA	Battery Voltage	MS	Frequency x 1000
O	Output	C	CAN Network	V	Voltage (DC)	ms	Milliseconds
SG	Signal Ground	S	SCP Network	Fz	Frequency	mV	Millivolts

**CAUTION:** The information on this data page is furnished to aid the user in understanding circuit operation. THIS INFORMATION SHOULD BE USED FOR REFERENCE ONLY.

**NOTE:** The values listed are approximately those that can be expected at the control module connector pins with all circuit connections made and all components connected and fitted. "Active" means a load is applied or a switch is ON; "inactive" means a load is not applied or a switch is OFF.

Refer to the front of this book for detailed information and illustrations regarding the location and identification of harnesses, relays, grounds, control modules and control module pins.

DATE OF ISSUE: September 1999

DATE OF ISSUE

## DATA PAGE

## FIGURE MODEL RANGE AND YEAR TITLE FIGURE NUMBER

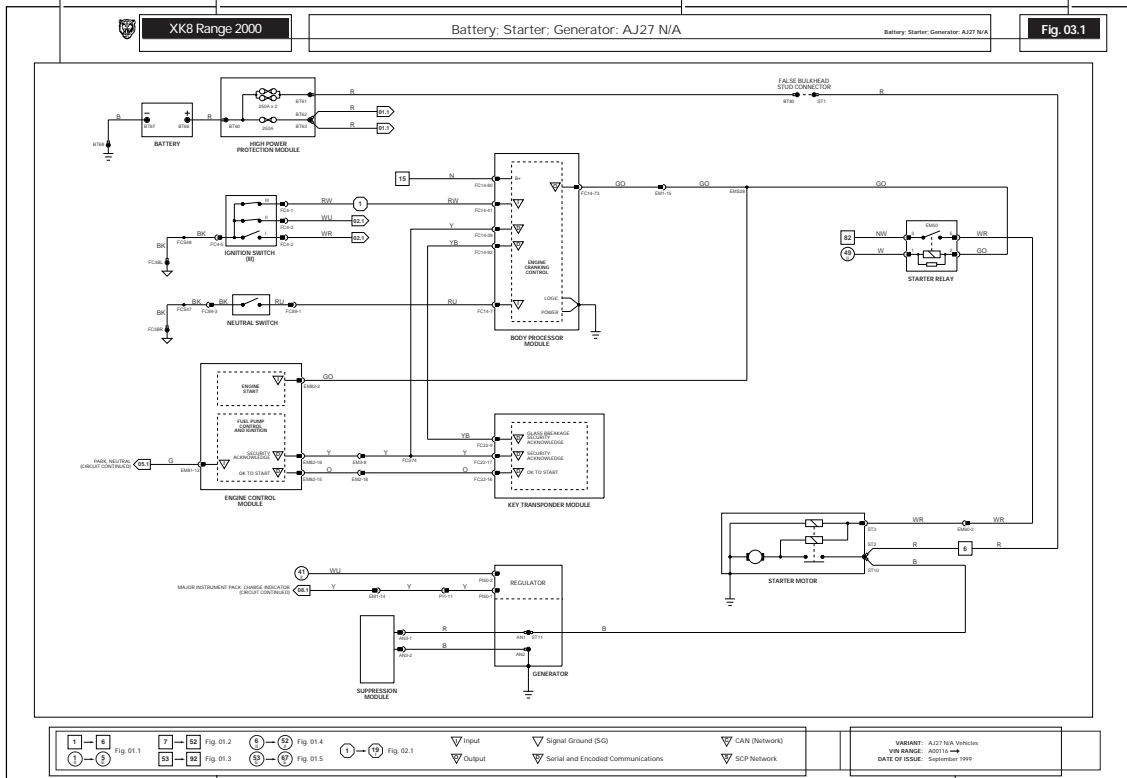

KEY TO REFERENCE SYMBOLS

## FIGURE PAGE

VARIANT, VIN RANGE AND DATE OF ISSUE



**NOTE: In the examples shown on this page, an 'X' is used where a number would appear on an actual Figure.**

### Reference Symbols

Reference symbols are used for three purposes:

- to allow the user to complete the individual system circuit to power supply or ground
- to refer the user to a related circuit
- to identify control module inputs, outputs and signal grounds

#### **Battery Power Supply**

This symbol represents a direct battery power supply and refers the user to Figure 01.1, 01.2 or 01.3.

#### **Ignition Switched Power Supply**

This symbol represents ignition switched power supply and refers the user to Figure 01.1, 01.4 or 01.5.

The suffix I indicates auxiliary power. Power is supplied in ignition switch key positions I (AUXILIARY) and II (IGNITION).

The suffix II indicates ignition power. Power is supplied in ignition switch key positions II (IGNITION) and III (ENGINE CRANK).

The suffix E indicates engine management switched power. Power is supplied in ignition switch key positions II (IGNITION) and III (ENGINE CRANK) under ECM control.

#### **Ignition Switched Ground**

This symbol represents an ignition switched ground and refers the user to Figure 02.1.

This symbol without a suffix indicates CRANK. Ground is completed in ignition switch key position III (ENGINE CRANK).

The suffix I indicates auxiliary ground. Ground is completed in ignition switch key positions I (AUXILIARY) and II (IGNITION).

The suffix II indicates ignition ground. Ground is completed in ignition switch key positions II (IGNITION) and III (ENGINE CRANK).

#### **Figure Number Reference Flag**

This symbol refers the reader to a figure number only. It does not refer to a flag with the same number on a different figure.

As used in Figures 01.1 through 02.1, the reference flag refers the user to a continuation of the circuit. In this instance, the user matches the number to a Power Supply or Ground symbol to trace the circuit.

In most other cases, it is not necessary to refer to another figure for completion of a circuit, as the reference flags are used to indicate parallel circuits and circuits that share components. Most of the circuits where this situation occurs are overlapped to avoid the necessity for cross-referencing to another figure. Exceptions to this rule are instances where signals are transmitted to or received from other system circuits. When circuits are not overlapped, they are noted by (CIRCUIT CONTINUED).

**BPM** Because the Body Processor Module appears numerous times, the abbreviation BPM is used in the reference flags on Figures 01.2 and 02.1 in order to conserve space.

### Control Module Input, Output, Data Link, Signal Ground and Network(s)

-  Input     Output     Serial and Encoded Communications     Signal Ground (SG)     CAN (Network)     SCP Network

These six symbols are employed to assist the user in visualizing the 'logic' of circuits containing control modules. The symbols identify control module input, output, data link, signal ground and network pins. These symbols are also employed on the corresponding data page.



## Wiring Symbols

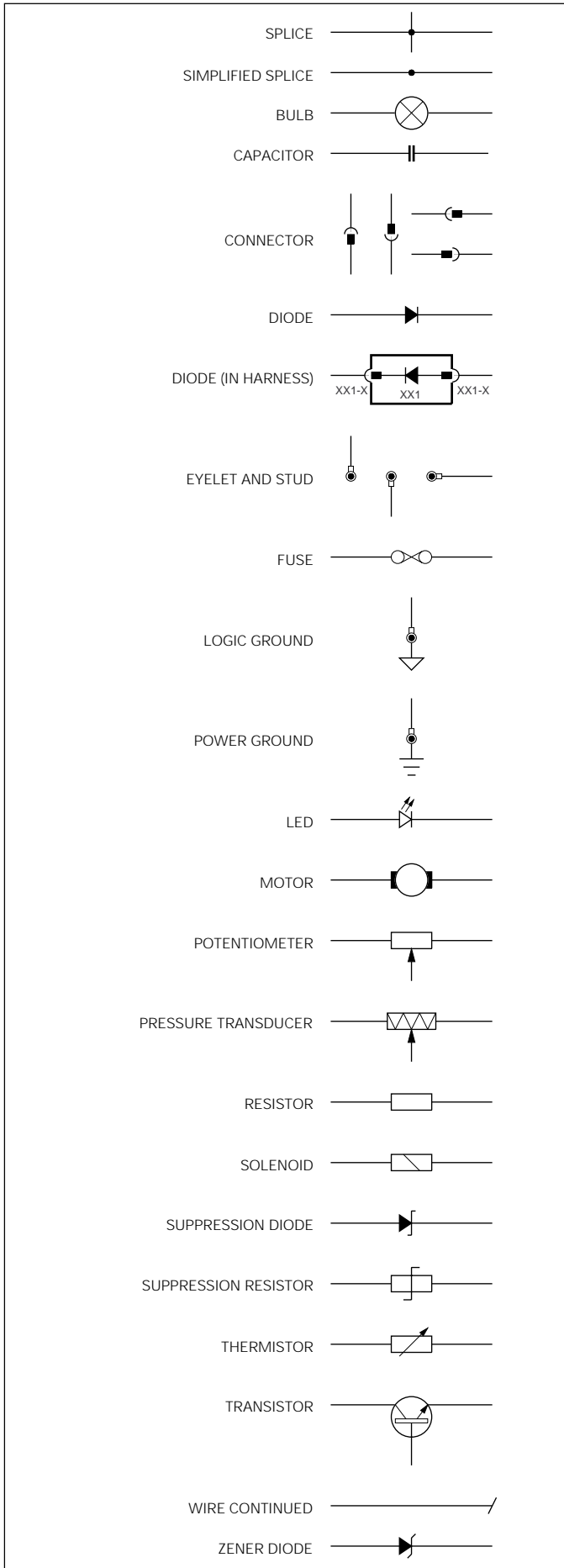

## Wiring Color Codes

N	Brown	O	Orange
B	Black	S	Slate
W	White	L	Light
K	Pink	U	Blue
G	Green	P	Purple
R	Red	BRD	Braid
Y	Yellow		

When a wire has two color code letters, the first letter indicates the main color and the subsequent letter indicates the tracer color.

## Wiring Harness Codes

Code	Description
AC	Air Conditioning (Climate Control)
AN	Generator Suppression Module
AS	Generator to Starter
BB	Trunk Bridging Link
BC	Main Power Distribution
BL	Trunk Lid
BT	Trunk
DD	Door, Driver
DP	Door, Passenger
EL	Engine Management Speed Control Link
EM	Engine Management
EN	Engine Management Side Marker Link
FC	Fascia
FL	LH Front Wheel
FR	RH Front Wheel
IC	In-Car Entertainment
IS	Inclination Sensor Link
LF	Left Forward
LL	Power Steering Link
PI	Engine
QL	Convertible LH Quarter Light Link
QR	Convertible RH Quarter Light Link
RF	Roof
RH	Rearward
RL	LH Rear Wheel
RR	RH Rear Wheel
RT	Radio Telephone
SA	Starter to Generator Link
SC	Column Switchgear
SD	Seat, Driver
SP	Seat, Passenger
SW	Steering Wheel
TL	Telephone

## Code Numbering

When numbering connectors, grounds and splices, Jaguar Engineering uses a three-position format: AC001, AC002, etc. Because space is limited in this Electrical Guide, the codes have been shortened. Thus AC001-001 becomes AC1-1, AC002-001 becomes AC2-1, etc.



## Harness Component Numbers

### Connectors

HARNESS CODE + CONNECTOR NUMBER + PIN NUMBER

EXAMPLE: FC7-24 (pin number is separated by a dash)

Where the pin number differs from LHD to RHD, the connector number will be further identified by (LHD) or (RHD).

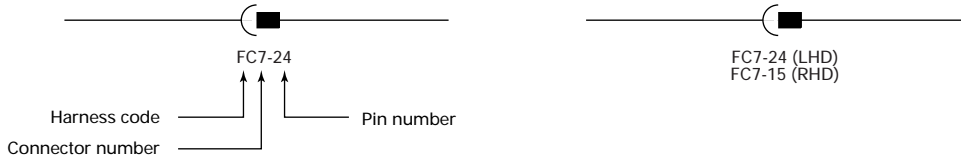

### Splices

HARNESS CODE + S (SPLICE) + SPLICE NUMBER

EXAMPLE: RHS3 (no dash is used)

NOTE: In order to avoid unnecessary circuit complication, multiple splices (more than two wires) within components, in wires leading from input components to multiple circuits and in harness 'ground' sides, are simplified so as not to show wires from other circuits.

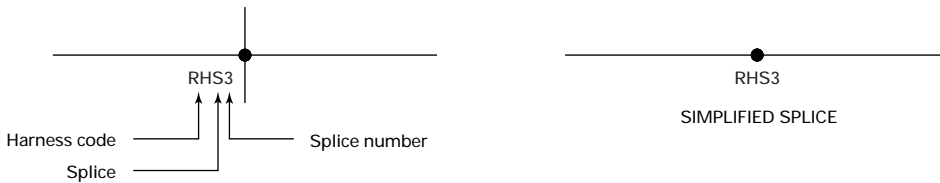

### Diodes

Harness diodes occur at connectors and are depicted as components and identified by a connector number.

EXAMPLE:



### Relay Connectors

Relay connector numbers are shown within the relay. The connector number is shown in the upper portion of the relay; the pin (terminal) number is shown adjacent to the pin. Certain relays are paired and share a modular connector. In this instance, the connector number remains the same for both relays while the pin numbers of the second relay are identified by numbers 6 – 10.

EXAMPLE:

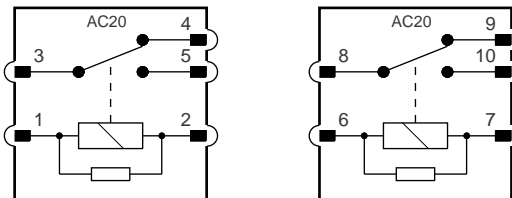



**Grounds**

HARNESS CODE + GROUND STUD NUMBER + EYELET STUD POSITION (A,B,C) + EYELET DESIGNATION (S,L,R)

**Eyelet stud position**

There may be up to three eyelets on one stud. A, B and C are used to indicate the position of the eyelet on the stud: A – first (bottom), B – second (middle), C – third (top).

**Eyelet designation**

Two eyelet variations are used: a single eyelet and an eyelet pair. The single eyelet has a single 'leg', which is identified by an S; the eyelet pair has two 'legs', identified as L (left) or R (right).

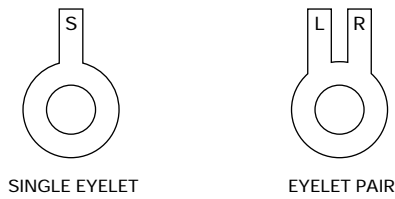

**EXAMPLES:**

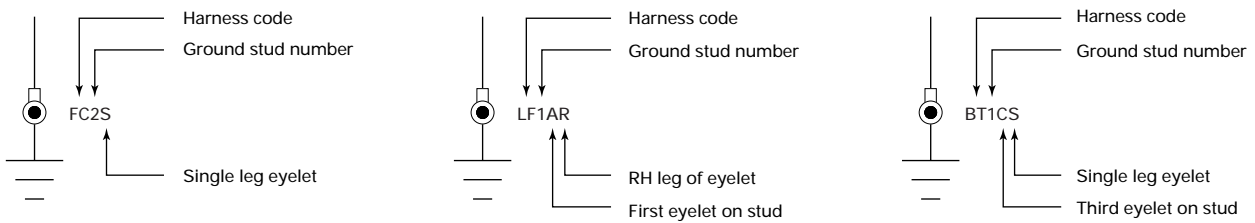

Where the ground designation differs from LHD to RHD, the RHD ground is shown in parentheses. If the ground designation is the same for LHD and RHD, only one ground designation is used.

**EXAMPLES:**







The following connectors are the common harness-to-harness connectors used throughout the vehicle.

**Multilock 040**

Low current (used as harness and 'direct' connection connector).

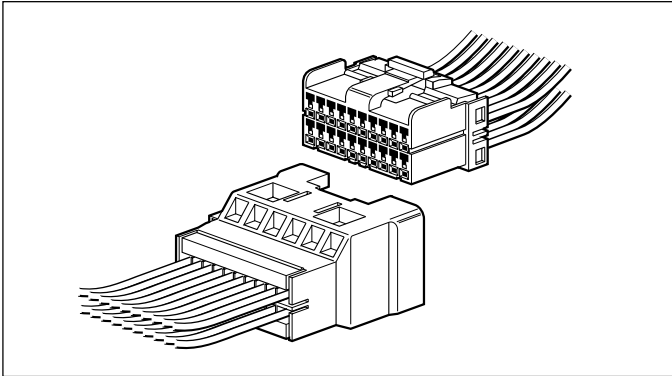
**Multilock 070**

High current (used as harness and 'direct' connection connector).

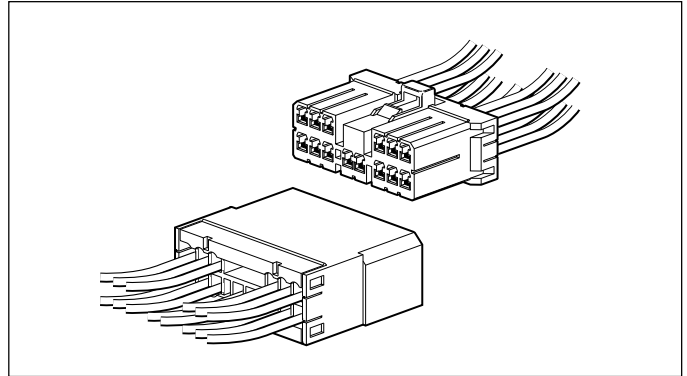
**Econoseal III LC**

Low current sealed connector.

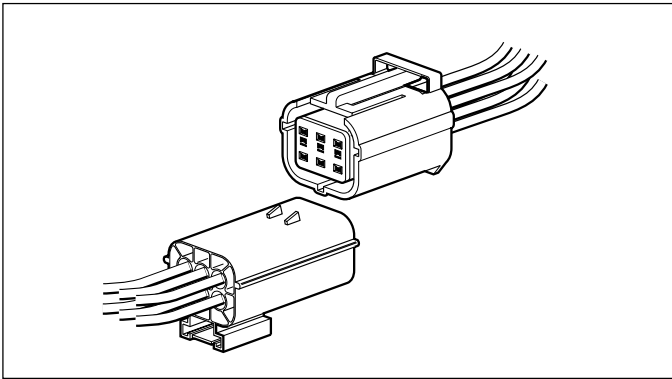
**Econoseal III HC**

High current sealed connector.

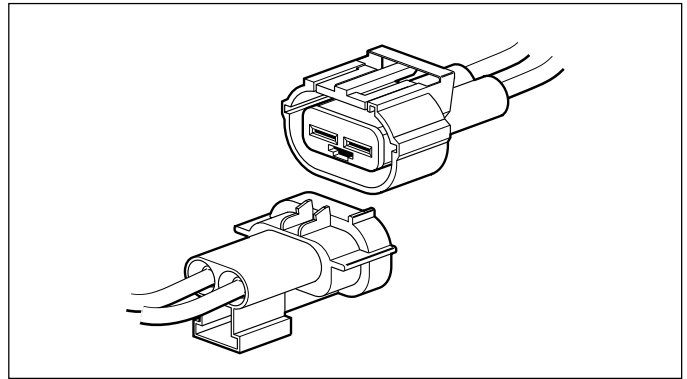
**Ford Card**

Used for SRS only.

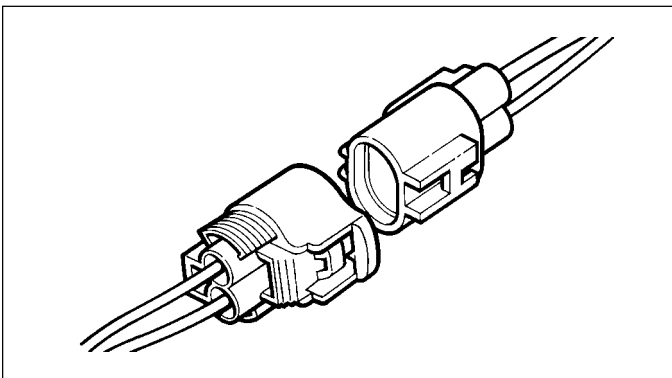

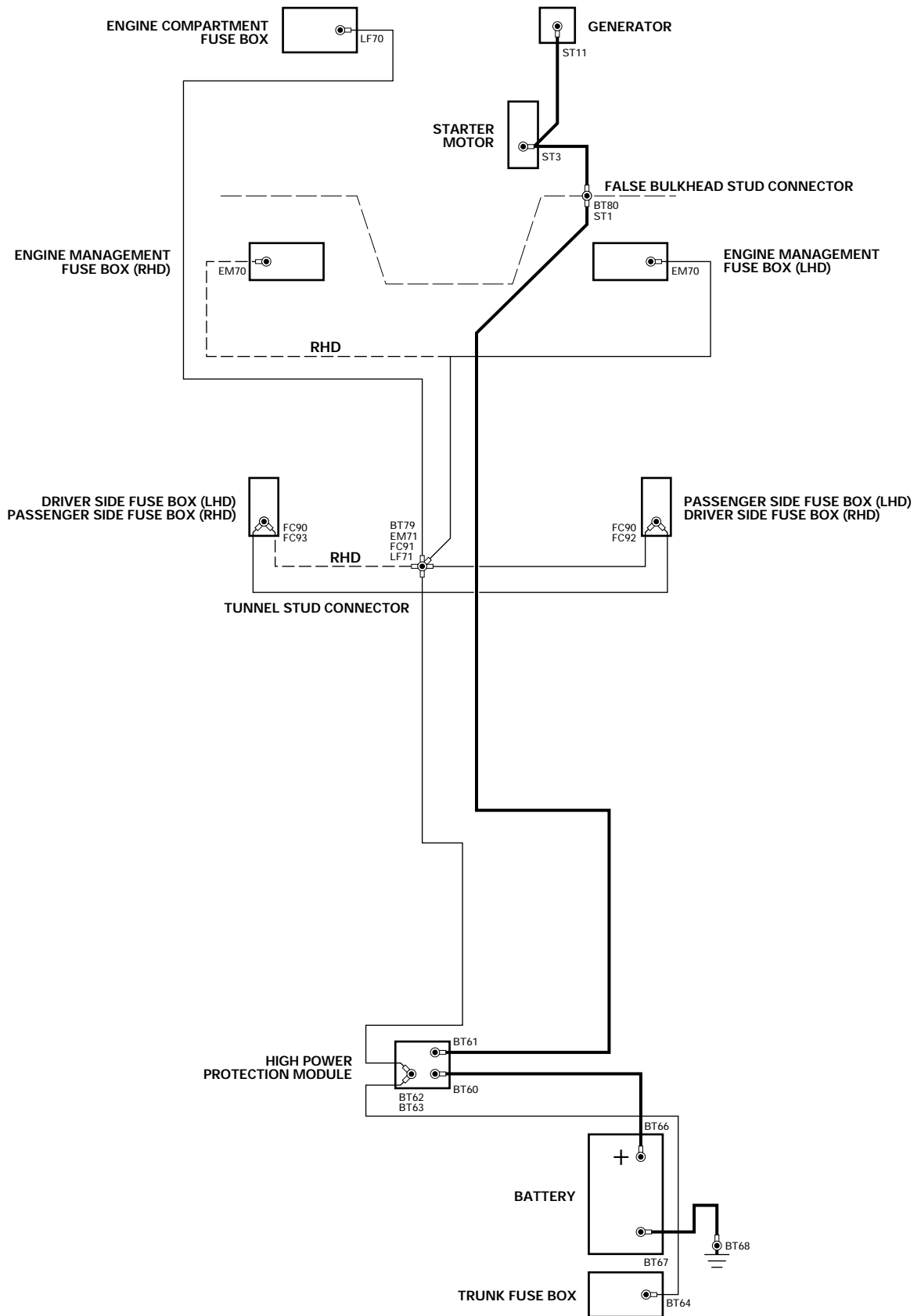



# LHD

FRONT OF VEHICLE

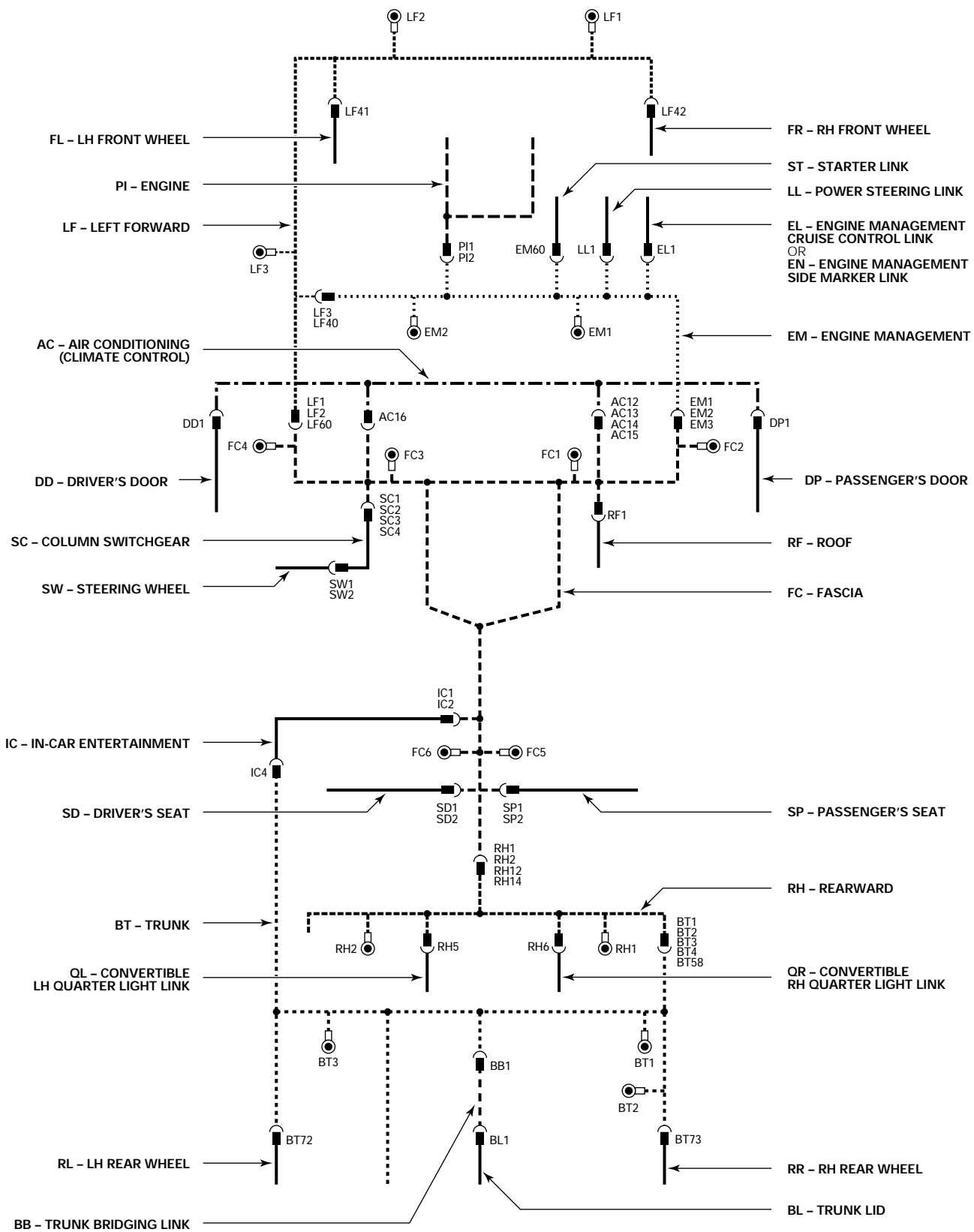



# RHD

FRONT OF VEHICLE

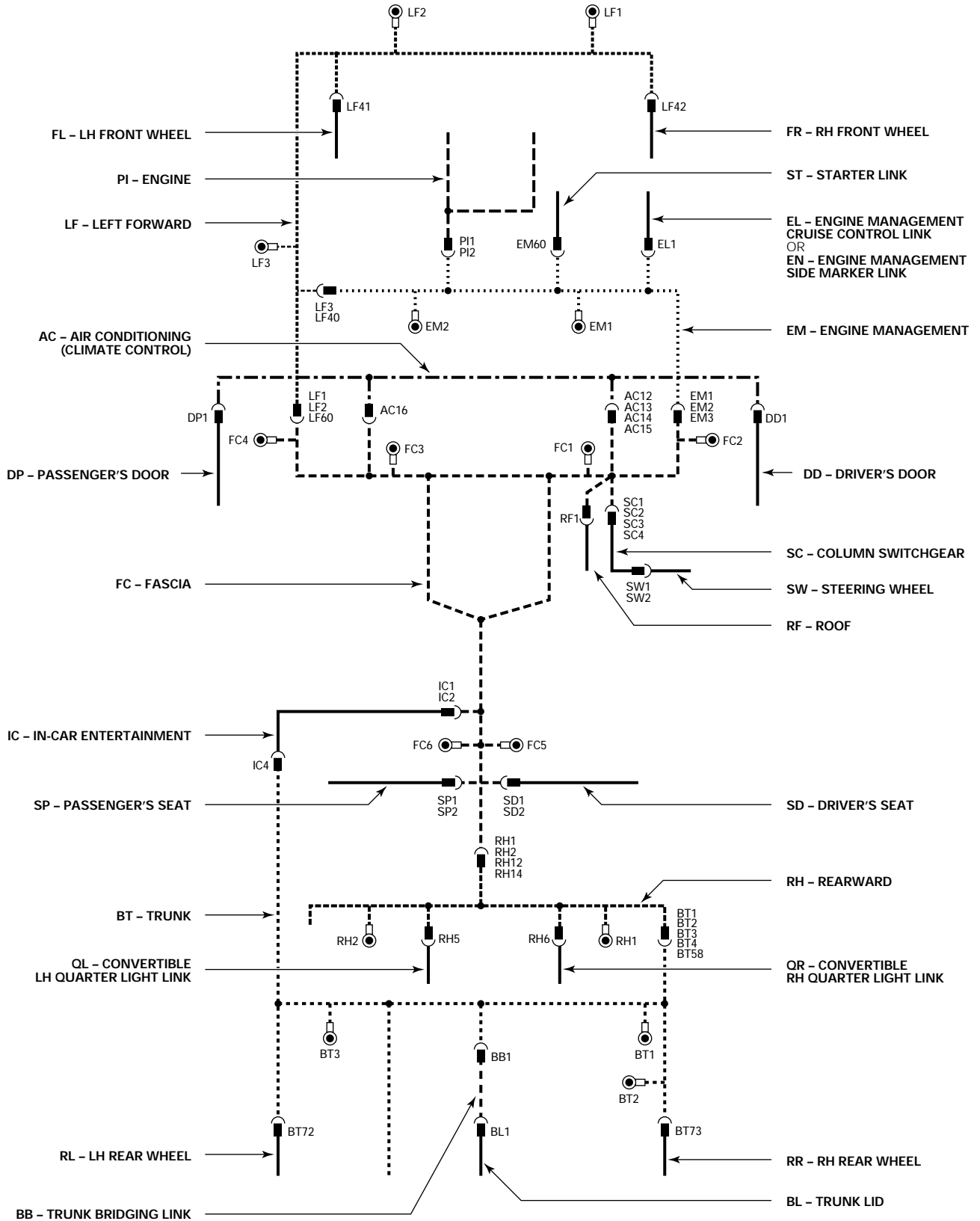

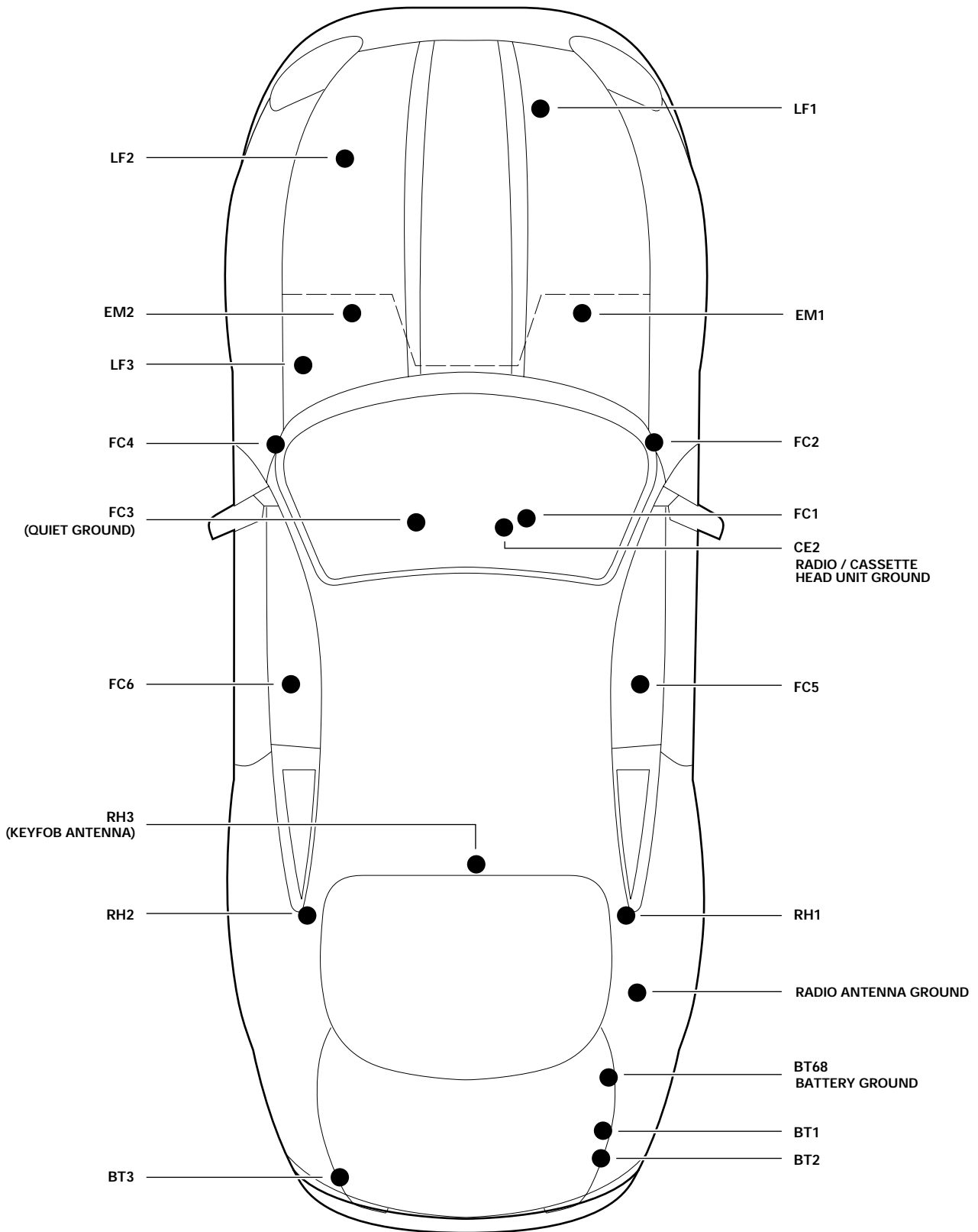

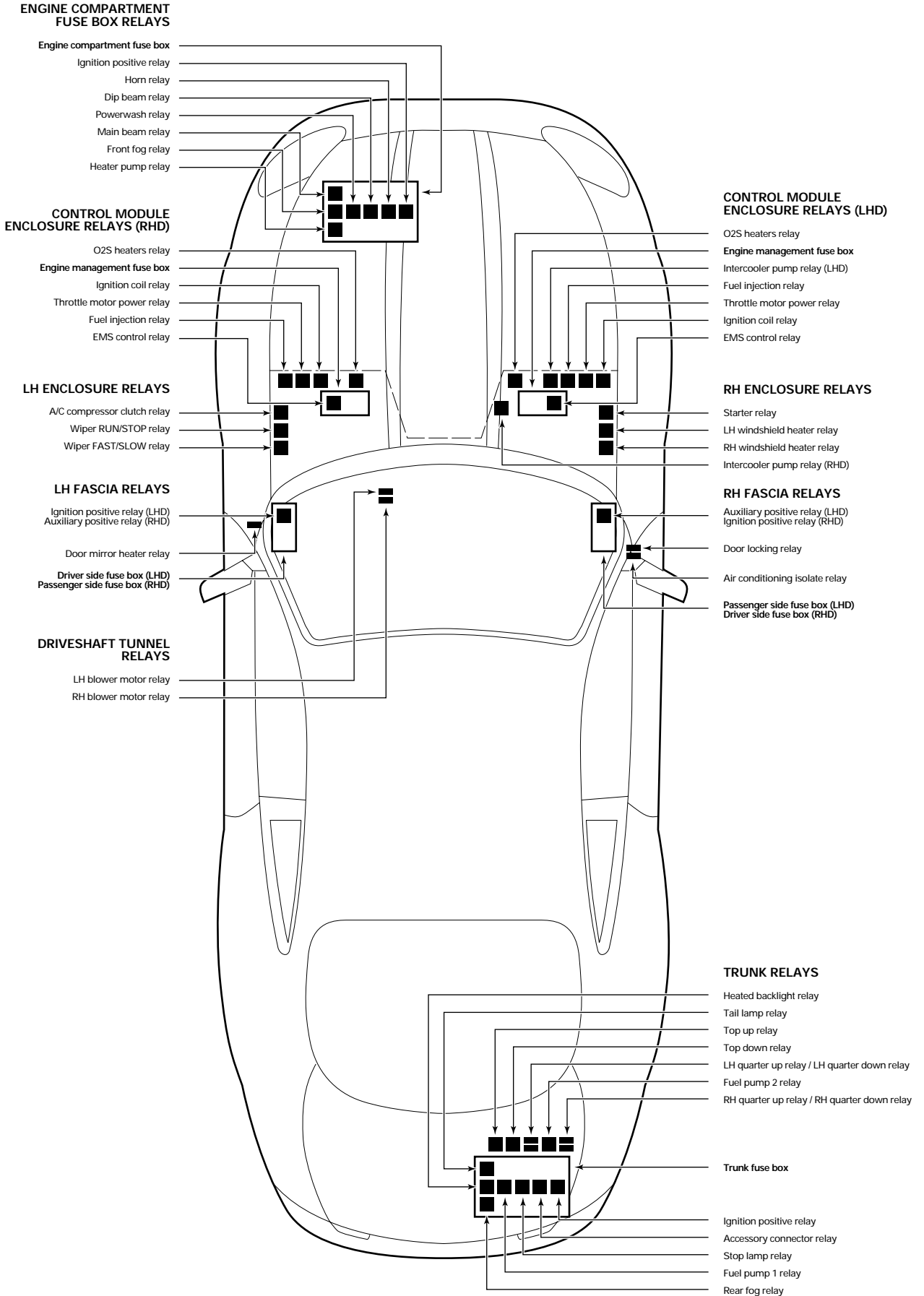

NOTE: All relays are brown, with the exception of the microrelays, which are black.



# LHD

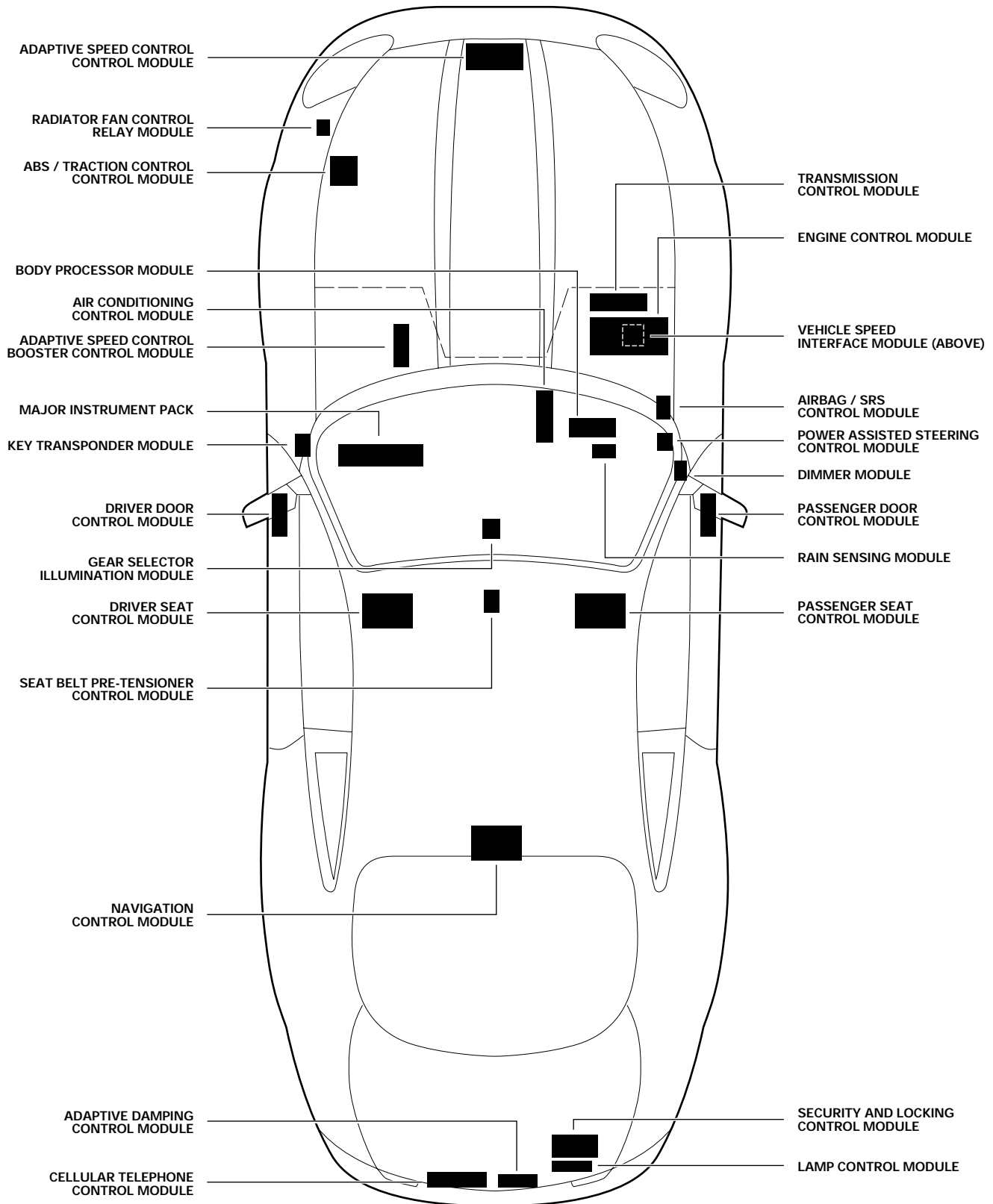



# RHD

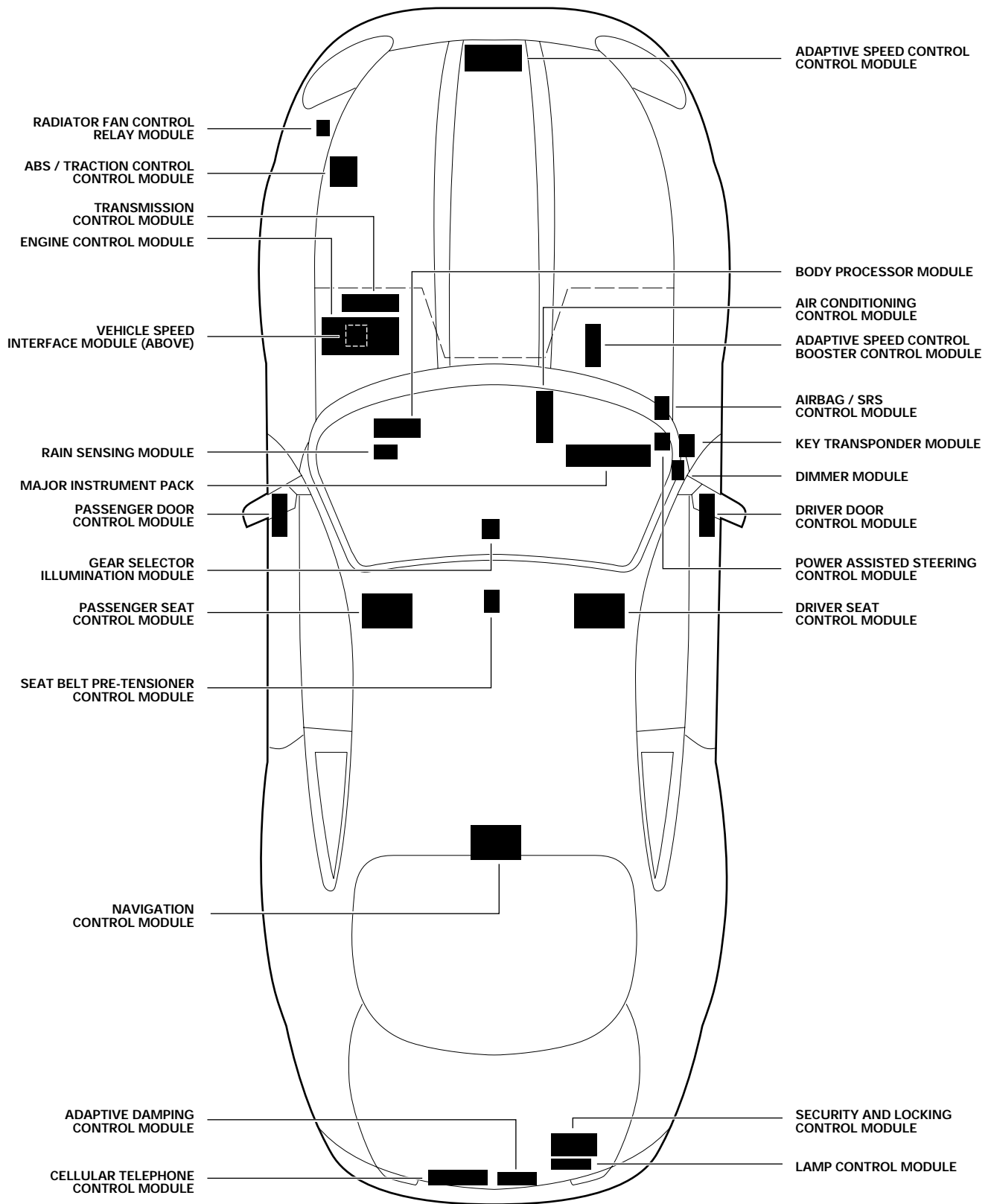





ENGINE CONTROL MODULE: AJ27 N/A

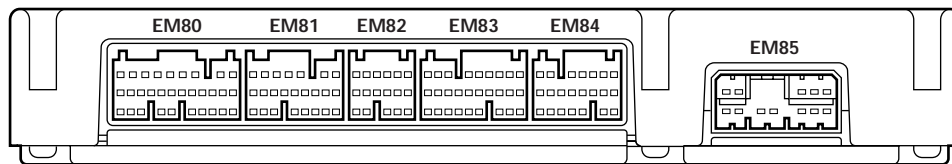

EM80 / 31-WAY / NATURAL

9	8	7	6	5	4	3	2	1			
GW	GW	R	R	G	G	B	O*	UY			
21	20	19	18	17	16	15	14	13	12	11	10
B	U	W	W	O	YU	YG	—	—	U	UY	WU
31	30	29	28	27	26	25	24	23	22		
B	—	BK	—	U	—	RW	—	UY	Y		

EM81 / 24-WAY / NATURAL

7	6	5	4	3	2	1		
RG	OG	W	WU	U	RW	OY		
16	15	14	13	12	11	10	9	8
RG*	YG	YR	WU	G	—	U	K	B
24	23	22	21	20	19	18	17	
BG	—	OY	B	—	G	R	WR	

EM82 / 17-WAY / NATURAL

6	5	4	3	2	1
GR	G	R	—	GO	OY
12	11	10	9	8	7
GU	W	Y	W	OG	BG
17	16	15	14	13	
O	Y	O	UY	WR	

EM83 / 28-WAY / NATURAL

9	8	7	6	5	4	3	2	1	
N	Y	P	BG	OY	WR	RU	—	—	
19	18	17	16	15	14	13	12	11	10
G	B	O	G	G	S	BG	BR	YG	YG
28	27	26	25	24	23	22	21	20	
GW	BW	BW	Y	Y	N	N	U	NR	

EM84 / 22-WAY / NATURAL

7	6	5	4	3	2	1	
U	BW	BW	BW	BO	BG	B	
15	14	13	12	11	10	9	8
UY	BG	BR	GU	GR	GO	GW	—
22	21	20	19	18	17		
B	BO	GB	GW	GO	GU	B	

\* Not used – ROW Vehicles.

EM85 / 312-WAY / WHITE

5	4	3	2	1
U	—	—	UY	RU
12	11	10	9	8
—	—	—	—	B
WG	7	6		
B	B	B		

ENGINE CONTROL MODULE: AJ27 SC

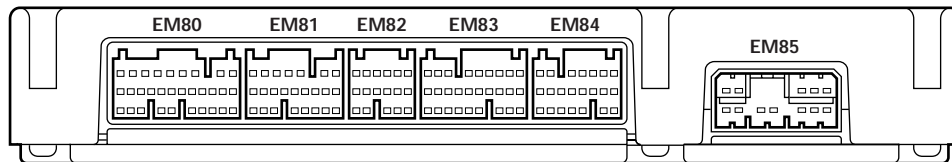

EM80 / 31-WAY / NATURAL

9	8	7	6	5	4	3	2	1			
GW	GW	R	R	G	G	B	O*	UY			
21	20	19	18	17	16	15	14	13	12	11	10
B	U	W	W	O	YU	YG	—	—	U	UY	WU
31	30	29	28	27	26	25	24	23	22		
B	—	BK	BW*	U	—	RW	—	UY	Y		

EM81 / 24-WAY / NATURAL

7	6	5	4	3	2	1		
RG	OG	W	WU	U	RW	OY		
16	15	14	13	12	11	10	9	8
RG*	YG	YR	WU	G	—	U	K	B
24	23	22	21	20	19	18	17	
BG	O	OY	B	—	G	R	WR	

EM82 / 17-WAY / NATURAL

6	5	4	3	2	1
GR	G	R	—	GO	OY
12	11	10	9	8	7
GU	W	Y	W	OG	BG
17	16	15	14	13	
O	Y	O	UY	WR	

EM83 / 28-WAY / NATURAL

9	8	7	6	5	4	3	2	1	
N	Y	P	BG	OY	WR	RU	—	—	
19	18	17	16	15	14	13	12	11	10
G	B	O	G	G	S	BG	BR	YG	YG
28	27	26	25	24	23	22	21	20	
GW	BW	BW	Y	Y	N	N	U	NR	

EM84 / 22-WAY / NATURAL

7	6	5	4	3	2	1	
U	BW	BW	BW	BO	BG	B	
15	14	13	12	11	10	9	8
UY	BG	BR	GU	GR	GO	GW	—
22	21	20	19	18	17		
B	BO	GB	GW	GO	GU	B	

\* Not used – ROW Vehicles.

EM85 / 12-WAY / WHITE

5	4	3	2	1
U	YG*	YU*	UY	RU
12	11	10	9	8
—	—	YR*	YR*	B
WG	7	6		
B	B	B		

\* Not used – ROW Vehicles.

**TRANSMISSION CONTROL MODULE: AJ27 N/A**

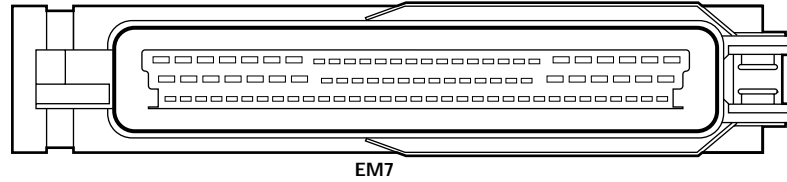

**EM7 / 88-WAY / BLACK**

1	2	3	4	5	6	7	8	9	10	11	12	13	14	15	16	17	18	19	20	21	22	23	24	25	26	27	28					
BY	-	ND	-	-	BRD	UY	BU	-	-	BS	-	U	BRD	N	US	RP	-	-	W	RB	-	B	OG	OK	-	RS	OU					
29	30	31	32	33	34	35	36	37	38	39	40	41	42	43	44	45	46	47	48	49	50	51	52	53	54	55						
WB	WB	RU	RY	OB	-	-	-	-	-	RG	R	-	G	-	-	-	-	Y	S	-	B	YP	YU	-	YB	OR						
56	57	58	59	60	61	62	63	64	65	66	67	68	69	70	71	72	73	74	75	76	77	78	79	80	81	82	83	84	85	86	87	88
-	-	Y	G	-	Y	G	-	-	-	-	-	-	-	-	-	-	-	-	-	-	-	-	-	-	-	-	-	-	-	-	-	-

**TRANSMISSION CONTROL MODULE: AJ27 SC**

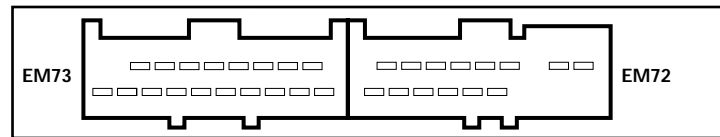

**EM73 / 18-WAY / BLACK**

23	24	25	26	27	28	29	30		
-	-	GB	GU	GU	GR	WB	B		
1	2	3	4	5	6	7	8	9	10
G	BW	RU	-	-	-	-	-	-	-

**EM72 / 14-WAY / BLACK**

33	34	35	36	37	38
BW	UY	U	O	O	RW
L	H				
G	Y				
12	13	14	15	16	17
G	BG	YB	YU	YU	OG





**ABS / TRACTION CONTROL CONTROL MODULE**

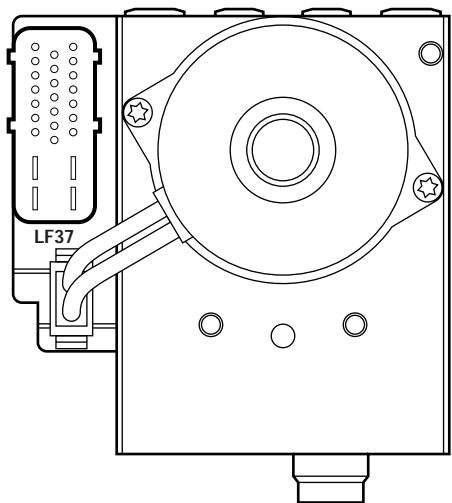

**LF37 / 25-WAY / BLACK**

1 UY	10 —	17 W
2 OG	11 —	18 R
3 Y	12 —	19 O
4 G	13 U	20 WU
5 Y	14 R	21 W
6 Y	15 G	22 U
7 O	16 RW	23 —
8 B	24 B	
9 NR	25 NW	

**ADAPTIVE DAMPING CONTROL MODULE**

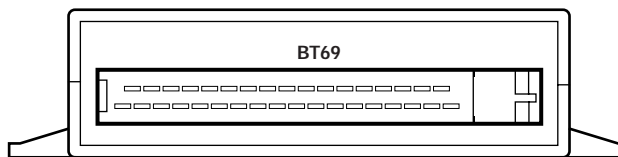

**BT69 / 35-WAY / BLACK**

19 —	20 BG	21 U	22 R	23 —	24 OG	25 U	26 OG	27 NW	28 W	29 —	30 O	31 OY	32 O	33 GU	34 OY	35 —	
1 YR	2 —	3 OY	4 —	5 —	6 —	7 —	8 —	9 —	10 O	11 WR	12 —	13 R	14 OG	15 OG	16 —	17 —	18 B



### AIR CONDITIONING CONTROL MODULE

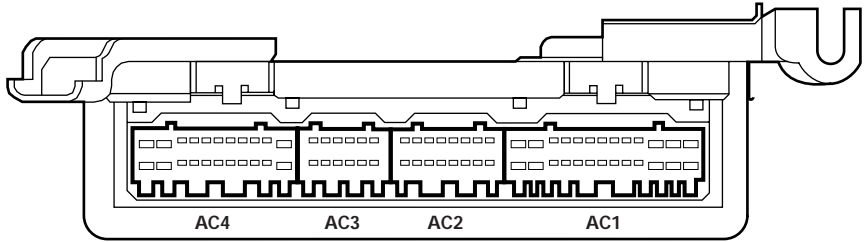

AC4 / 22-WAY / GREY

12 WR	13 B	14 B	15 —	16 —	17 U	18 GW	19 BW	20 BK	21 O	22 —
1 —	2 —	3 —	4 WU	5 —	6 —	7 U	8 U	9 UY	10 W	11 —

AC3 / 12-WAY / GREY

7 Y	8 YR	9 —	10 —	11 U	12 WU
1 UY	2 Y	3 YG	4 —	5 OY	6 U

AC2 / 16-WAY / GREY

9 —	10 O	11 YG	12 —	13 UY	14 —	15 U	16 GU
1 OG	2 RG	3 Y	4 —	5 YB	6 —	7 OG	8 GO

AC1 / 26-WAY / GREY

14 —	15 —	16 GR	17 RW	18 GU	19 RU	20 YR	21 Y	22 NR	23 —	24 —	25 O	26 GU
1 RG	2 U	3 UY	4 UY	5 GR	6 RW	7 UY	8 RW	9 R	10 —	11 —	12 OY	13 UY



## MAJOR INSTRUMENT PACK

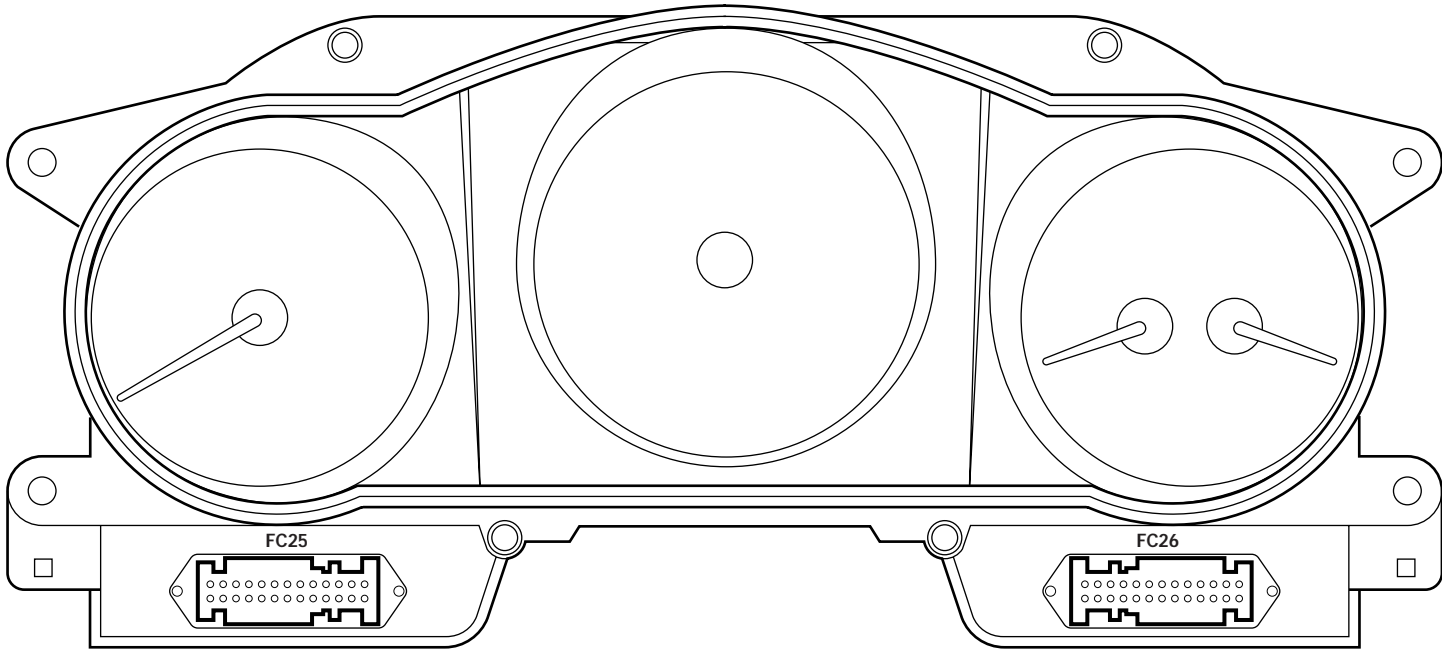

FC25 / 26-WAY / BLACK

1 WG	2 RG	3 YR	4 BK	5 —	6 RU	7 YB	8 UY	9 R	10 Y	11 Y	12 —	13 Y
14 U	15 R	16 B	17 RW	18 Y	19 O	20 —	21 —	22 —	23 G	24 G	25 BR	26 —

FC26 / 26-WAY / YELLOW

13 BW	12 RU	11 R	10 O	9 RU	8 RG	7 OG	6 U	5 OY	4 YG	3 RW	2 OY	1 R
26 —	25 —	24 —	23 OG	22 Y	21 RG	20 OY	19 G	18 OG	17 OY	16 Y	15 OY	14 RW

### BODY PROCESSOR MODULE

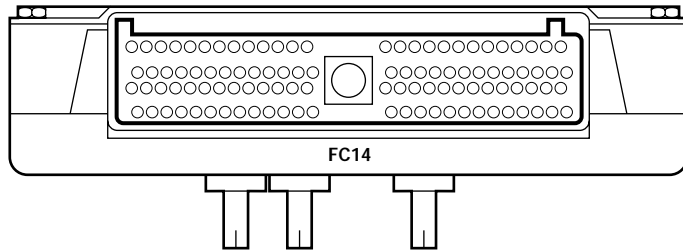

**FC14 / 104-WAY / GREY**

79 NG	80 N	81 GR	82 GR	83 GB	84 U	85 Y	86 OG	87 Y	88 YG	89 GR	90 BG	91 BW	92 YB	93 Y	94 G	95 RU	96 N	97 WG	98 GB	99 UY	100 BR	101 RW	102 N	103 —	104 NW
53 R	54 G	55 YU	56 OY	57 —	58 YB	59 Y	60 RW	61 WG	62 GU	63 Y	64 —	65 —	66 RU	67 O	68 OG	69 O	70 GW	71 YR	72 —	73 GO	74 RW	75 —	76 GO	77 GU	78 U
27 GO	28 RW	29 Y	30 U	31 Y	32 WR	33 RG	34 GO	35 G	36 GW	37 GR	38 O	39 Y	40 WU	41 RW	42 UY	43 BG	44 OY	45 U	46 —	47 —	48 OG	49 —	50 GW	51 RW	52 BW
1 RW	2 GW	3 W	4 GU	5 YR	6 Y	7 RU	8 —	9 GU	10 YR	11 YB	12 W	13 GO	14 U	15 WU	16 RW	17 OY	18 YB	19 WG	20 OG	21 —	22 WB	23 WU	24 NW	25 B	26 YG

### LAMP CONTROL MODULE

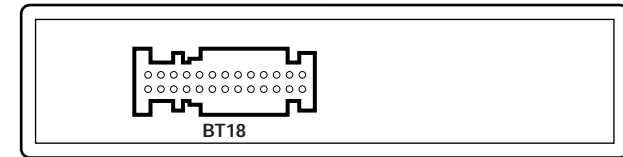

**BT18 / 26-WAY / YELLOW**

1 —	2 —	3 —	4 —	5 —	6 —	7 —	8 —	9 —	10 —	11 —	12 —	13 —
14 O	15 UY	16 RW	17 R	18 RU	19 U	20 OY	21 RU	22 RG	23 RW	24 WG	25 R	26 BK

### SECURITY AND LOCKING CONTROL MODULE

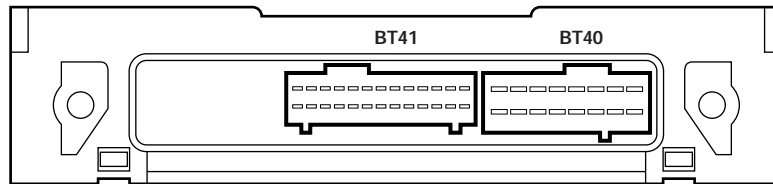

**BT41 / 26-WAY / BLACK**

13 —	12 —	11 —	10 BK	9 —	8 GW	7 YU	6 —	5 RW	4 —	3 GW*	2 —	1 R
26 YR	25 —	24 —	23 —	22 —	21 —	20 —	19 YR	18 —	17 —	16 —	15 —	14 —

**BT40 / 16-WAY / BLACK**

8 Y	7 OG	6 NR	5 Y	4 GW*	3 U*	2 O	1 O
16 U	15 NW	14 BK	13 BK	12 —	11 —	10 UY*	9 GR*

\* Not used - COUPE Vehicles.

### KEY TRANSPONDER MODULE

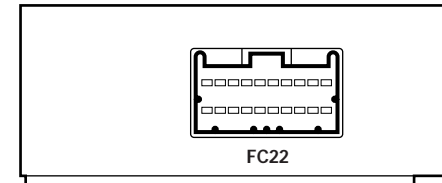

**FC22 / 20-WAY / GREEN**

10 —	9 YB	8 OG	7 O	6 O	5 —	4 NR	3 —	2 —	1 YB
20 —	19 —	18 —	17 Y	16 O	15 —	14 WU	13 WR	12 BK	11 —





## DRIVER DOOR CONTROL MODULE

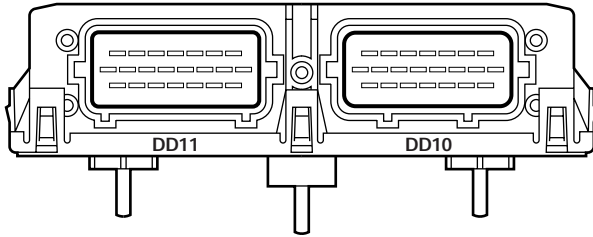

DD11 / 22-WAY / BLACK

7	6	5	4	3	2	1	
BR	WU	GU	NG	YR	U	NR	
15	14	13	12	11	10	9	8
WG	—	—	OY	—	WB	Y	BK
22	21	20	19	18	17	16	—
UY	O	GW	—	—	O	—	—

DD10 / 22-WAY / BLUE

7	6	5	4	3	2	1	
O	YB	Y	UY	U	BW	N	
15	14	13	12	11	10	9	8
OY	GW	UY	RW	U	BG	U	BK
22	21	20	19	18	17	16	—
OG	RU	WU	GB	BO	B	Y	—

## PASSENGER DOOR CONTROL MODULE

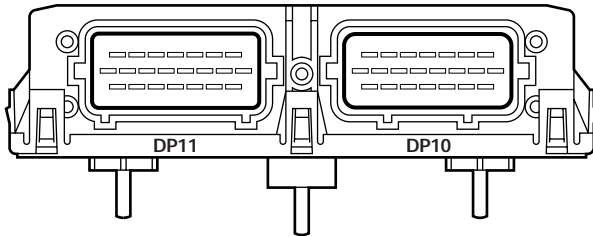

DP11 / 22-WAY / BLACK

7	6	5	4	3	2	1	
—	—	GU	—	—	—	—	
15	14	13	12	11	10	9	8
—	—	—	—	—	—	—	—
22	21	20	19	18	17	16	—
—	—	GW	—	—	—	—	—

DP10 / 22-WAY / BLUE

7	6	5	4	3	2	1	
O	YB	Y	UY	U	BW	N	
15	14	13	12	11	10	9	8
OY	GW	UY	RW	U	BG	U	BK
22	21	20	19	18	17	16	—
OG	RU	WU	—	BO	B	Y	—

**DRIVER SEAT CONTROL MODULE**

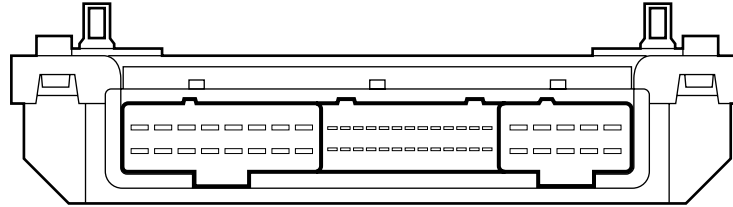

SD3 SD4 SD5

**SD3 / 16-WAY / BLACK**

9 UY	10 OY	11 W	12 WG	13 GR	14 GU	15 GW	16 BW
1 UY	2 BG	3 O	4 —	5 YU	6 O	7 WU	8 WR

**SD4 / 26-WAY / BLACK**

14 WU	15 —	16 —	17 —	18 WB	19 —	20 —	21 —	22 —	23 —	24 —	25 —	26 —
1 WG	2 WU	3 —	4 —	5 W	6 G	7 —	8 —	9 —	10 WR	11 YG	12 UY	13 —

**SD5 / 10-WAY / BLACK**

6 —	7 —	8 G	9 Y	10 U
1 BO	2 B	3 OG	4 UY	5 NR

**PASSENGER SEAT CONTROL MODULE**

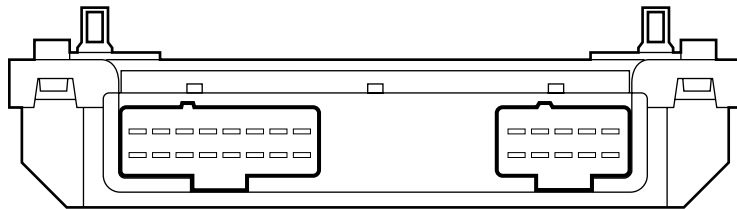

SP3 SP5

**SP3 / 16-WAY / BLACK**

9 UY	10 OY	11 W	12 WG	13 GR	14 GU	15 GW	16 BW
1 UY	2 BG	3 O	4 —	5 YU	6 O	7 WU	8 WR

**SP5 / 10-WAY / BLACK**

6 —	7 —	8 G	9 Y	10 U
1 BO	2 B	3 OG	4 UY	5 NR

**AIRBAG / SRS CONTROL MODULE**

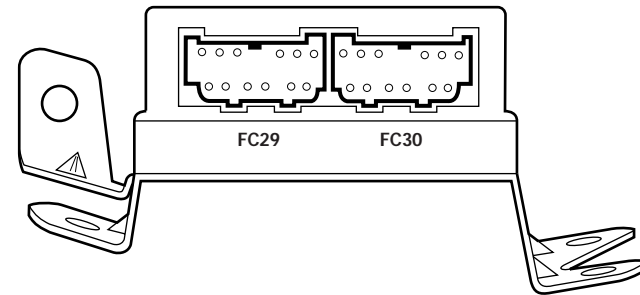

FC29 FC30

**FC29 / 12-WAY / BLACK**

7 WG	8 OY	9 OG	10 —	11 YU	12 OG
1 —	2 —	3 —	4 BK	5 Y	6 R

**FC30 / 12-WAY / GREY**

12 BK	11 RU	10 WU	9 WG	8 RW	7 RW
6 W	5 RG	4 WU	3 WR	2 RU	1 —





# Fig. 01.1

## COMPONENTS

Component	Connector / Type / Color	Location / Access
VVT SOLENOID VALVE: VARIABLE VALVE TIMING SOLENOID VALVE - BATTERY	PI32 / 2-WAY AMP JUNIOR POWER TIMER / BLACK BT66 / EYELET	TRUNK, RIGHT HAND SIDE BT67 / EYELET
BODY PROCESSOR MODULE FUSE BOX - DRIVER SIDE	FC14 / 104-WAY AMP EEEEC / GREY FC5 / 10-WAY U.T.A. FUSEBOX / NATURAL	PASSENGER SIDE FASCIA / AIRBAG BRACKET FASCIA / DRIVER SIDE FC6 / 10-WAY U.T.A. FUSEBOX / BLACK FC90 / EYELET FC92 / EYELET
FUSE BOX - ENGINE COMPARTMENT	LF5 / 10-WAY U.T.A. FUSEBOX / NATURAL	ENGINE COMPARTMENT / LEFT FRONT LF6 / 10-WAY U.T.A. FUSEBOX / BLACK LF7 / 10-WAY U.T.A. FUSEBOX / GREEN LF8 / 10-WAY U.T.A. FUSEBOX / BLUE LF70 / EYELET
FUSE BOX - ENGINE MANAGEMENT	EM19 / 10-WAY U.T.A. FUSEBOX / NATURAL	ENGINE COMPARTMENT / CONTROL MODULE ENCLOSURE EM20 / 10-WAY U.T.A. FUSEBOX / BLACK EM70 / EYELET
FUSE BOX - PASSENGER SIDE	FC20 / 10-WAY U.T.A. FUSEBOX / NATURAL	FASCIA / PASSENGER SIDE FC21 / 10-WAY U.T.A. FUSEBOX / BLACK FC90 / EYELET FC93 / EYELET
FUSE BOX - TRUNK	BT10 / 10-WAY U.T.A. FUSEBOX / NATURAL	TRUNK / ELECTRICAL CARRIER BT11 / 10-WAY U.T.A. FUSEBOX / BLACK BT12 / 10-WAY U.T.A. FUSEBOX / GREEN BT13 / 10-WAY U.T.A. FUSEBOX / BLUE BT64 / EYELET
HIGH POWER PROTECTION MODULE	BT60 / EYELET	TRUNK / ADJACENT TO BATTERY BT61 / EYELET BT62 / EYELET BT63 / EYELET
TRANSIT ISOLATION DEVICE	BT44 / 2-WAY ECONOSEAL III HC / BLACK	TRUNK / ADJACENT TO BATTERY BT49 / 1-WAY LUCAR BT65 / EYELET BT66 / EYELET

## RELAYS

Relay	Color / Stripe	Connector / Color	Location / Access
AUXILIARY POSITIVE RELAY	BROWN	BUS	PASSENGER SIDE FUSE BOX
EMS CONTROL RELAY	BROWN	BUS	ENGINE MANAGEMENT FUSE BOX
IGNITION POSITIVE RELAY	BROWN	BUS	DRIVER SIDE FUSE BOX
IGNITION POSITIVE RELAY	BROWN	BUS	ENGINE COMPARTMENT FUSE BOX
IGNITION POSITIVE RELAY	BROWN	BUS	TRUNK FUSE BOX

## HARNESS-TO-HARNESS CONNECTORS

Connector	Type / Color	Location / Access
BT2	20-WAY MULTILOCK 070 / WHITE	TRUNK / ABOVE RIGHT HAND REAR WHEEL ARCH
BT79	EYELET	TRANSMISSION TUNNEL
BT80	EYELET	ENGINE COMPARTMENT / FALSE BULKHEAD, RIGHT HAND SIDE
EM71	EYELET	TRANSMISSION TUNNEL
FC91	EYELET	TRANSMISSION TUNNEL
LF71	EYELET	TRANSMISSION TUNNEL
RH2	20-WAY MULTILOCK 070 / WHITE	REAR OF CENTER CONSOLE ASSEMBLY
ST1	EYELET	ENGINE COMPARTMENT / FALSE BULKHEAD, RIGHT HAND SIDE

## GROUNDS

Ground	Location / Type
BT68	BATTERY GROUND STUD
BT2BR	EYELET (PAIR) - RIGHT HAND LEG / TRUNK, RIGHT REAR
BT2BS	EYELET (SINGLE) / TRUNK, RIGHT REAR

Refer to the front of this book for detailed information and illustrations regarding the location and identification of harnesses, relays, grounds, control modules and control module pins.

**COMPONENTS**

Component	Connector / Type / Color	Location / Access
FUSE BOX – DRIVER SIDE	FC5 / 10-WAY U.T.A. FUSEBOX / NATURAL FC6 / 10-WAY U.T.A. FUSEBOX / BLACK FC90 / EYELET FC92 / EYELET	FASCIA / DRIVER SIDE
FUSE BOX – PASSENGER SIDE	FC20 / 10-WAY U.T.A. FUSEBOX / NATURAL FC21 / 10-WAY U.T.A. FUSEBOX / BLACK FC90 / EYELET FC93 / EYELET	FASCIA / PASSENGER SIDE

**HARNESS-TO-HARNESS CONNECTORS**

Connector	Type / Color	Location / Access
AC12	20-WAY MULTILOCK 070 / WHITE	FASCIA TOP CONNECTOR MOUNTING BRACKET / RIGHT HAND SIDE
AC13	20-WAY MULTILOCK 070 / YELLOW	FASCIA BOTTOM CONNECTOR MOUNTING BRACKET / RIGHT HAND SIDE
AC14	14-WAY MULTILOCK 070 / GREY	FASCIA BOTTOM CONNECTOR MOUNTING BRACKET / RIGHT HAND SIDE
AC15	20-WAY MULTILOCK 070 / GREY	FASCIA BOTTOM CONNECTOR MOUNTING BRACKET / RIGHT HAND SIDE
AC16	6-WAY MULTILOCK 070 / YELLOW	LEFT HAND 'A' POST CONNECTOR MOUNTING BRACKET / 'A' POST TRIM
BT2	20-WAY MULTILOCK 070 / WHITE	TRUNK / ABOVE RIGHT HAND REAR WHEEL ARCH
BT58	4-WAY ECONOSEAL III HC / BLACK	TRUNK / ABOVE RIGHT HAND REAR WHEEL ARCH
DD1	23-WAY AMP – FORD / BLACK	DRIVER SIDE 'A' POST MOUNTING BRACKET / 'A' POST TRIM
DP1	23-WAY AMP – FORD / BLACK	PASSENGER SIDE 'A' POST / 'A' POST TRIM
IC2	14-WAY MULTILOCK 070 / WHITE	BELOW CENTER CONSOLE GLOVE BOX
LF1	20-WAY MULTILOCK 070 / GREY	LEFT HAND 'A' POST CONNECTOR MOUNTING BRACKET / 'A' POST TRIM
RF1	18-WAY MULTILOCK 070 / YELLOW	RIGHT HAND 'A' POST CONNECTOR MOUNTING BRACKET / 'A' POST TRIM
RH14	2-WAY ECONOSEAL III HC / BLACK	REAR OF CENTER CONSOLE ASSEMBLY
RH2	20-WAY MULTILOCK 070 / WHITE	REAR OF CENTER CONSOLE ASSEMBLY
SD1	8-WAY MULTILOCK 070 / YELLOW	BELOW DRIVER SEAT
SP1	8-WAY MULTILOCK 070 / YELLOW	BELOW PASSENGER SEAT

Refer to the front of this book for detailed information and illustrations regarding the location and identification of harnesses, relays, grounds, control modules and control module pins.

**Fig. 01.3**

**COMPONENTS**

Component	Connector / Type / Color	Location / Access
FUSE BOX - ENGINE COMPARTMENT	LF5 / 10-WAY U.T.A. FUSEBOX / NATURAL LF6 / 10-WAY U.T.A. FUSEBOX / BLACK LF7 / 10-WAY U.T.A. FUSEBOX / GREEN LF8 / 10-WAY U.T.A. FUSEBOX / BLUE LF70 / EYELET	ENGINE COMPARTMENT / LEFT FRONT
FUSE BOX - ENGINE MANAGEMENT	EM19 / 10-WAY U.T.A. FUSEBOX / NATURAL EM20 / 10-WAY U.T.A. FUSEBOX / BLACK EM70 / EYELET	ENGINE COMPARTMENT / CONTROL MODULE ENCLOSURE
FUSE BOX - TRUNK	BT10 / 10-WAY U.T.A. FUSEBOX / NATURAL BT11 / 10-WAY U.T.A. FUSEBOX / BLACK BT12 / 10-WAY U.T.A. FUSEBOX / GREEN BT13 / 10-WAY U.T.A. FUSEBOX / BLUE BT64 / EYELET	TRUNK / ELECTRICAL CARRIER

**HARNESSTO-HARNESSTO CONNECTORS**

Connector	Type / Color	Location / Access
BT1	20-WAY MULTILOCK 070 / WHITE	TRUNK / ABOVE RIGHT HAND REAR WHEEL ARCH
IC4	4-WAY MULTILOCK 070 / WHITE	TRUNK / LEFT OF ANTENNA ASSEMBLY
RH12	18-WAY MULTILOCK 070 / YELLOW	REAR OF CENTER CONSOLE ASSEMBLY

Refer to the front of this book for detailed information and illustrations regarding the location and identification of harnesses, relays, grounds, control modules and control module pins.

**Fig. 01.4****COMPONENTS**

Component	Connector / Type / Color	Location / Access
FUSE BOX - DRIVER SIDE	FC5 / 10-WAY U.T.A. FUSEBOX / NATURAL FC6 / 10-WAY U.T.A. FUSEBOX / BLACK FC90 / EYELET FC92 / EYELET	FASCIA / DRIVER SIDE
FUSE BOX - ENGINE COMPARTMENT	LF5 / 10-WAY U.T.A. FUSEBOX / NATURAL LF6 / 10-WAY U.T.A. FUSEBOX / BLACK LF7 / 10-WAY U.T.A. FUSEBOX / GREEN LF8 / 10-WAY U.T.A. FUSEBOX / BLUE LF70 / EYELET	ENGINE COMPARTMENT / LEFT FRONT
FUSE BOX - PASSENGER SIDE	FC20 / 10-WAY U.T.A. FUSEBOX / NATURAL FC21 / 10-WAY U.T.A. FUSEBOX / BLACK FC90 / EYELET FC93 / EYELET	FASCIA / PASSENGER SIDE
FUSE BOX - TRUNK	BT10 / 10-WAY U.T.A. FUSEBOX / NATURAL BT11 / 10-WAY U.T.A. FUSEBOX / BLACK BT12 / 10-WAY U.T.A. FUSEBOX / GREEN BT13 / 10-WAY U.T.A. FUSEBOX / BLUE BT64 / EYELET	TRUNK / ELECTRICAL CARRIER

**HARNESS-TO-HARNESS CONNECTORS**

Connector	Type / Color	Location / Access
AC15	20-WAY MULTILOCK 070 / GREY	FASCIA BOTTOM CONNECTOR MOUNTING BRACKET / RIGHT HAND SIDE
BT1	20-WAY MULTILOCK 070 / WHITE	TRUNK / ABOVE RIGHT HAND REAR WHEEL ARCH
EM2	20-WAY MULTILOCK 070 / YELLOW	ENGINE COMPARTMENT / ADJACENT TO RIGHT HAND ENCLOSURE
IC2	14-WAY MULTILOCK 070 / WHITE	BELOW CENTER CONSOLE GLOVE BOX
IC3	14-WAY MULTILOCK 070 / GREY	BELOW CENTER CONSOLE GLOVE BOX
LF3	13-WAY ECONOSEAL III LC / WHITE	ENGINE COMPARTMENT / LEFT HAND ENCLOSURE
LF40	13-WAY ECONOSEAL III LC / BLACK	ENGINE COMPARTMENT / LEFT HAND ENCLOSURE
LF60	20-WAY MULTILOCK 070 / WHITE	LEFT HAND 'A' POST CONNECTOR MOUNTING BRACKET / 'A' POST TRIM
PI2	13-WAY ECONOSEAL III LC / BLACK	ENGINE COMPARTMENT / BRACKET ON TOP OF TRANSMISSION
RF1	18-WAY MULTILOCK 070 / YELLOW	RIGHT HAND 'A' POST CONNECTOR MOUNTING BRACKET / 'A' POST TRIM
RH2	20-WAY MULTILOCK 070 / WHITE	REAR OF CENTER CONSOLE ASSEMBLY

Refer to the front of this book for detailed information and illustrations regarding the location and identification of harnesses, relays, grounds, control modules and control module pins.

**Fig. 01.5**

**COMPONENTS**

<b>Component</b>	<b>Connector / Type / Color</b>	<b>Location / Access</b>
FUSE BOX - ENGINE MANAGEMENT	EM19 / 10-WAY U.T.A. FUSEBOX / NATURAL EM20 / 10-WAY U.T.A. FUSEBOX / BLACK EM70 / EYELET	ENGINE COMPARTMENT / CONTROL MODULE ENCLOSURE

**HARNESS-TO-HARNESS CONNECTORS**

<b>Connector</b>	<b>Type / Color</b>	<b>Location / Access</b>
BT1	20-WAY MULTILOCK 070 / WHITE	TRUNK / ABOVE RIGHT HAND REAR WHEEL ARCH
EM3	14-WAY MULTILOCK 070 / GREY	ENGINE COMPARTMENT / ADJACENT TO RIGHT HAND ENCLOSURE
LF3	13-WAY ECONOSEAL III LC / WHITE	ENGINE COMPARTMENT / LEFT HAND ENCLOSURE
LF40	13-WAY ECONOSEAL III LC / BLACK	ENGINE COMPARTMENT / LEFT HAND ENCLOSURE
PI1	57-WAY SUMITOMO TS090 / BLACK	ENGINE COMPARTMENT / BRACKET ON TOP OF TRANSMISSION
RH2	20-WAY MULTILOCK 070 / WHITE	REAR OF CENTER CONSOLE ASSEMBLY

Refer to the front of this book for detailed information and illustrations regarding the location and identification of harnesses, relays, grounds, control modules and control module pins.

**Fig. 02.1**

**COMPONENTS**

**Component**

IGNITION SWITCH (KEY-IN SWITCH)  
INERTIA SWITCH

**Connector / Type / Color**

FC4 / 8-WAY MULTILOCK 070 / WHITE  
FC46 / 3-WAY ECONOSEAL III LC / BLACK

**Location / Access**

STEERING COLUMN  
ADJACENT TO LEFT HAND FASCIA FUSE BOX

**HARNESS-TO-HARNESS CONNECTORS**

**Connector**

AC13  
BT1  
LF60  
RH2

**Type / Color**

20-WAY MULTILOCK 070 / YELLOW  
20-WAY MULTILOCK 070 / WHITE  
20-WAY MULTILOCK 070 / WHITE  
20-WAY MULTILOCK 070 / WHITE

**Location / Access**

FASCIA BOTTOM CONNECTOR MOUNTING BRACKET / RIGHT HAND SIDE  
TRUNK / ABOVE RIGHT HAND REAR WHEEL ARCH  
LEFT HAND 'A' POST CONNECTOR MOUNTING BRACKET / 'A' POST TRIM  
REAR OF CENTER CONSOLE ASSEMBLY

**GROUNDS**

**Ground**

FC3BL

**Location / Type**

EYELET (PAIR) - LEFT HAND LEG / TRANSMISSION TUNNEL, LEFT HAND SIDE

Refer to the front of this book for detailed information and illustrations regarding the location and identification of harnesses, relays, grounds, control modules and control module pins.

**CONTROL MODULE PIN OUT INFORMATION**

**Fig. 03.1**

**BODY PROCESSOR MODULE**

Pin	Description	Active	Inactive
I FC14-7	NEUTRAL SWITCH STATUS	GROUND (N)	B+ (P, R, D, 4, 3, 2)
D FC14-39	SECURITY ACKNOWLEDGE	ENCODED COMMUNICATIONS	
I FC14-41	STARTER ENGAGE REQUEST	GROUND (CRANKING)	B+
O FC14-73	STARTER RELAY ACTIVATE	GROUND (CRANKING)	B+
I FC14-80	BATTERY SUPPLY VOLTAGE	B+	
D FC14-92	ENCODED COMMUNICATIONS		

**ENGINE CONTROL MODULE**

Pin	Description	Active	Inactive
I EM81-12	PARK / NEUTRAL CONFIRMATION	B+ (P, N)	GROUND (R,D,4,3,2)
I EM82-2	ENGINE CRANK	GROUND (CRANKING)	
D EM82-15	OK TO START	ENCODED COMMUNICATIONS	
D EM82-16	SECURITY ACKNOWLEDGE	ENCODED COMMUNICATIONS	

**KEY TRANSPONDER MODULE**

Pin	Description	Active	Inactive
D FC22-9	GLASS BREAKAGE / OK TO START (ENCODED COMMUNICATION)		
D FC22-16	OK TO START (ENCODED COMMUNICATION)		
D FC22-17	SECURITY ACKNOWLEDGE (ENCODED COMMUNICATION)		

**COMPONENTS**

Component	Connector / Type / Color	Location / Access
BATTERY	BT66 / EYELET BT67 / EYELET	TRUNK, RIGHT HAND SIDE
BODY PROCESSOR MODULE ENGINE CONTROL MODULE	FC14 / 104-WAY AMP EEEEC / GREY EM80 / 31-WAY AMP 403 / NATURAL EM81 / 24-WAY AMP 403 / NATURAL EM82 / 17-WAY AMP 403 / NATURAL EM83 / 28-WAY AMP 403 / NATURAL EM84 / 22-WAY AMP 403 / NATURAL EM85 / 12-WAY MULTILOCK 070 / WHITE	PASSENGER SIDE FASCIA / AIRBAG BRACKET ENGINE COMPARTMENT / CONTROL MODULE ENCLOSURE
GENERATOR	AN1 / EYELET AN2 / EYELET ST11 / EYELET	ENGINE COMPARTMENT / RIGHT FRONT
HIGH POWER PROTECTION MODULE	BT60 / EYELET BT61 / EYELET BT62 / EYELET BT63 / EYELET	TRUNK / ADJACENT TO BATTERY
IGNITION SWITCH (KEY-IN SWITCH) KEY TRANSPONDER MODULE NEUTRAL SWITCH REGULATOR (GENERATOR) STARTER MOTOR	FC4 / 8-WAY MULTILOCK 070 / WHITE FC22 / 20-WAY MULTILOCK 040 / GREEN FC89 / 3-WAY MULTILOCK 070 / GREY PI50 / 3-WAY SUMITOMO 0902 / BLACK ST2 / EYELET ST3 / EYELET ST10 / EYELET	STEERING COLUMN ADJACENT TO DRIVER SIDE FUSE BOX GEAR SELECTOR ASSEMBLY ENGINE COMPARTMENT / GENERATOR ENGINE BLOCK
SUPPRESSION MODULE	AN3 / 2-WAY ECONOSEAL III LC/ RED	REARWARD OF RIGHT FRONT HEADLAMP

**RELAYS**

Relay	Color / Stripe	Connector / Color	Location / Access
STARTER RELAY	BROWN	EM50 / BROWN	RH ENCLOSURE RELAYS

**HARNESSTO-HARNESSTCONNECTORS**

Connector	Type / Color	Location / Access
BT80	EYELET	ENGINE COMPARTMENT / FALSE BULKHEAD, RIGHT HAND SIDE
EM1	20-WAY MULTILOCK 070 / WHITE	ENGINE COMPARTMENT / ADJACENT TO RIGHT HAND ENCLOSURE
EM2	20-WAY MULTILOCK 070 / YELLOW	ENGINE COMPARTMENT / ADJACENT TO RIGHT HAND ENCLOSURE
EM3	14-WAY MULTILOCK 070 / GREY	ENGINE COMPARTMENT / ADJACENT TO RIGHT HAND ENCLOSURE
EM60	2-WAY ECONOSEAL III HC / BLACK	ENGINE COMPARTMENT / BEHIND LEFT INNER FENDER HEAT SHIELD
PI1	57-WAY SUMITOMO TS090 / BLACK	ENGINE COMPARTMENT / BRACKET ON TOP OF TRANSMISSION
ST1	EYELET	ENGINE COMPARTMENT / FALSE BULKHEAD, RIGHT HAND SIDE

**GROUNDS**

Ground	Location / Type
BT68	BATTERY GROUND STUD
FC3BR	EYELET (PAIR) – RIGHT HAND LEG / TRANSMISSION TUNNEL, LEFT HAND SIDE

FOR CONTROL MODULE PIN OUT INFORMATION, UNFOLD PAGE TO LEFT.

The following abbreviations are used to represent values for Control Module Pin-Out data

I	Input	D	Serial and Encoded Data	B+	Battery Voltage	kHz	Frequency x 1000
O	Output	C	CAN (Network)	V	Voltage (DC)	ms	Milliseconds
SG	Signal Ground	S	SCP Network	Hz	Frequency	mV	Millivolts

CAUTION: The information on this data page is furnished to aid the user in understanding circuit operation. THIS INFORMATION SHOULD BE USED FOR REFERENCE ONLY.

NOTE: The values listed are approximately those that can be expected at the control module connector pins with all circuit connections made and all components connected and fitted. "Active" means a load is applied or a switch is ON; "Inactive" means a load is not applied or a switch is OFF.

Refer to the front of this book for detailed information and illustrations regarding the location and identification of harnesses, relays, grounds, control modules and control module pins.

**CONTROL MODULE PIN OUT INFORMATION**

**Fig. 03.2**

**BODY PROCESSOR MODULE**

Pin	Description	Active	Inactive
I FC14-7	NEUTRAL SWITCH STATUS	GROUND (N)	B+ (P, R, D, 4, 3, 2)
D FC14-39	SECURITY ACKNOWLEDGE	ENCODED COMMUNICATIONS	
I FC14-41	STARTER ENGAGE REQUEST	GROUND (CRANKING)	B+
O FC14-73	STARTER RELAY ACTIVATE	GROUND (CRANKING)	B+
I FC14-80	BATTERY SUPPLY VOLTAGE	GROUND (CRANKING)	B+
D FC14-92	ENCODED COMMUNICATIONS	B+	

**ENGINE CONTROL MODULE**

Pin	Description	Active	Inactive
I EM81-12	PARK / NEUTRAL CONFIRMATION	B+ (P, N)	GROUND (R,D,4,3,2)
I EM82-2	ENGINE CRANK	GROUND (CRANKING)	
D EM82-15	OK TO START	ENCODED COMMUNICATIONS	
D EM82-16	SECURITY ACKNOWLEDGE	ENCODED COMMUNICATIONS	

**KEY TRANSPONDER MODULE**

Pin	Description	Active	Inactive
D FC22-9	GLASS BREAKAGE / OK TO START (ENCODED COMMUNICATION)		
D FC22-16	OK TO START (ENCODED COMMUNICATION)		
D FC22-17	SECURITY ACKNOWLEDGE (ENCODED COMMUNICATION)		

**COMPONENTS**

Component	Connector / Type / Color	Location / Access
BATTERY	BT66 / EYELET BT67 / EYELET	TRUNK, RIGHT HAND SIDE
BODY PROCESSOR MODULE DUAL LINEAR SWITCH ENGINE CONTROL MODULE	FC14 / 104-WAY AMP EEEC / GREY FC100 / 12-WAYy / MULTILOCK 070 / GREY EM80 / 31-WAY AMP 403 / NATURAL EM81 / 24-WAY AMP 403 / NATURAL EM82 / 17-WAY AMP 403 / NATURAL EM83 / 28-WAY AMP 403 / NATURAL EM84 / 22-WAY AMP 403 / NATURAL EM85 / 12-WAY MULTILOCK 070 / WHITE	PASSENGER SIDE FASCIA / AIRBAG BRACKET LEFT HAND SIDE OF GEAR SELECTOR / CENTER CONSOLE ENGINE COMPARTMENT / CONTROL MODULE ENCLOSURE
GENERATOR	AN1 / EYELET AN2 / EYELET ST11 / EYELET	ENGINE COMPARTMENT / RIGHT FRONT
HIGH POWER PROTECTION MODULE	BT60 / EYELET BT61 / EYELET BT62 / EYELET BT63 / EYELET	TRUNK / ADJACENT TO BATTERY
IGNITION SWITCH (KEY-IN SWITCH) KEY TRANSPONDER MODULE REGULATOR (GENERATOR) STARTER MOTOR	FC4 / 8-WAY MULTILOCK 070 / WHITE FC22 / 20-WAY MULTILOCK 040 / GREEN PI50 / 3-WAY SUMITOMO 0902 / BLACK ST2 / EYELET ST3 / EYELET ST10 / EYELET	STEERING COLUMN ADJACENT TO DRIVER SIDE FUSE BOX ENGINE COMPARTMENT / GENERATOR ENGINE BLOCK
SUPPRESSION MODULE	AN3 / 2-WAY ECONOSEAL III LC/ RED	REARWARD OF RIGHT FRONT HEADLAMP

**RELAYS**

Relay	Color / Stripe	Connector / Color	Location / Access
STARTER RELAY	BROWN	EM50 / BROWN	RH ENCLOSURE RELAYS

**HARNESSTO-HARNES CONNECTORS**

Connector	Type / Color	Location / Access
BT80	EYELET	ENGINE COMPARTMENT / FALSE BULKHEAD, RIGHT HAND SIDE
EM1	20-WAY MULTILOCK 070 / WHITE	ENGINE COMPARTMENT / ADJACENT TO RIGHT HAND ENCLOSURE
EM2	20-WAY MULTILOCK 070 / YELLOW	ENGINE COMPARTMENT / ADJACENT TO RIGHT HAND ENCLOSURE
EM3	14-WAY MULTILOCK 070 / GREY	ENGINE COMPARTMENT / ADJACENT TO RIGHT HAND ENCLOSURE
EM60	2-WAY ECONOSEAL III HC / BLACK	ENGINE COMPARTMENT / BEHIND LEFT INNER FENDER HEAT SHIELD
PI1	57-WAY SUMITOMO TS090 / BLACK	ENGINE COMPARTMENT / BRACKET ON TOP OF TRANSMISSION
ST1	EYELET	ENGINE COMPARTMENT / FALSE BULKHEAD, RIGHT HAND SIDE

**GROUNDS**

Ground	Location / Type
BT68	BATTERY GROUND STUD
EM1AR	EYELET (PAIR) – RIGHT HAND LEG / ENGINE COMPARTMENT, RIGHT HAND ENCLOSURE
EM2AL	EYELET (PAIR) – LEFT HAND LEG / ENGINE COMPARTMENT, LEFT HAND ENCLOSURE

FOR CONTROL MODULE PIN OUT INFORMATION, UNFOLD PAGE TO LEFT.

The following abbreviations are used to represent values for Control Module Pin-Out data

I	Input	D	Serial and Encoded Data	B+	Battery Voltage	kHz	Frequency x 1000
O	Output	C	CAN (Network)	V	Voltage (DC)	ms	Milliseconds
SG	Signal Ground	S	SCP Network	Hz	Frequency	mV	Millivolts

**CAUTION:** The information on this data page is furnished to aid the user in understanding circuit operation. THIS INFORMATION SHOULD BE USED FOR REFERENCE ONLY.

**NOTE:** The values listed are approximately those that can be expected at the control module connector pins with all circuit connections made and all components connected and fitted. "Active" means a load is applied or a switch is ON; "Inactive" means a load is not applied or a switch is OFF.

Refer to the front of this book for detailed information and illustrations regarding the location and identification of harnesses, relays, grounds, control modules and control module pins.



**CONTROL MODULE PIN OUT INFORMATION**

**ENGINE CONTROL MODULE**

Pin	Description	Active	Inactive
O	EM80-01	EVAP VALVE ACTIVATE	GROUND (VALVE OPEN)
O	EM80-02	CANISTER CLOSE VALVE ACTIVATE	GROUND
I	EM80-03	GROUND (POWER)	GROUND
O	EM80-04	THROTTLE MOTOR POWER SUPPLY	B+
O	EM80-05	THROTTLE MOTOR POWER SUPPLY	B+
O	EM80-06	THROTTLE MOTOR POWER SUPPLY	B+
O	EM80-07	THROTTLE MOTOR POWER SUPPLY	B+
I	EM80-08	THROTTLE MOTOR POWER SUPPLY	B+
I	EM80-09	THROTTLE MOTOR POWER SUPPLY	B+
I	EM80-15	EOT FEEDBACK	2.5 V @ 34 °C; 0.5 V @ 90 °C; (DECREASING VOLTAGE WITH TEMPERATURE INCREASE)
D	EM80-17	SERIAL COMMUNICATIONS	
D	EM80-18	SERIAL COMMUNICATIONS	
D	EM80-19	ECM PROGRAMMING	
I	EM80-21	GROUND (THROTTLE MOTOR 1)	GROUND
D	EM80-27	ECM PROGRAMMING	
I	EM80-29	GROUND (LOGIC 2)	GROUND
I	EM80-31	GROUND (THROTTLE MOTOR 2)	GROUND
O	EM81-01	VARIABLE VALVE TIMING SOLENOID + 'A' BANK	B+ (12% DUTY CYCLE @ IDLE) (INCREASING WITH ADVANCE)
O	EM81-02	VARIABLE VALVE TIMING SOLENOID - 'A' BANK	GROUND
O	EM81-03	EMS CONTROLLED RELAY ACTIVATE	GROUND
O	EM81-06	VARIABLE VALVE TIMING SOLENOID + 'B' BANK	B+ (12% DUTY CYCLE @ IDLE) (INCREASING WITH ADVANCE)
O	EM81-07	VARIABLE VALVE TIMING SOLENOID - 'B' BANK	GROUND
I	EM81-08	GROUND (POWER)	GROUND
I	EM81-09	PEDAL POSITION FEEDBACK (PPS/1)	0.6 V = FOOT OFF; 3.8 V = PEDAL FULLY DEPRESSED
I	EM81-10	TPS FEEDBACK (TPS/1)	0.5 V = IDLE; 4.75 V = WOT
I	EM81-12	PARK / NEUTRAL CONFIRMATION	B+ (P, N)
I	EM81-16	FUEL TANK PRESSURE SENSOR FEEDBACK	4.9 V = LOW PRESSURE; 0.2 V = HIGH PRESSURE
I	EM81-17	EMS SWITCHED POWER SUPPLY 1	B+
I	EM81-18	PEDAL POSITION FEEDBACK (PPS/2)	0.8 V = FOOT OFF; 2.4 V = PEDAL FULLY DEPRESSED
I	EM81-19	TPS FEEDBACK (TPS/2)	0.6 V = IDLE; 4.85 V = WOT
I	EM81-21	GROUND (LOGIC 1)	GROUND
I	EM81-22	PARKING BRAKE SWITCH	GROUND (APPLIED)
SG	EM81-24	PEDAL POSITION / THROTTLE POSITION SENSORS SHIELD	GROUND
O	EM82-01	SENSOR SUPPLY VOLTAGE 1	5 V
I	EM82-02	ENGINE CRANK	GROUND (CRANKING)
I	EM82-04	HO2S, UPSTREAM 'A' BANK - VARIABLE CURRENT (µA)	3.5 V
I	EM82-05	HO2S, UPSTREAM 'B' BANK - VARIABLE CURRENT (µA)	3.5 V
O	EM82-06	THROTTLE MOTOR POWER RELAY ACTIVATE	GROUND
SG	EM82-07	SENSORS SIGNAL GROUND 1	GROUND
I	EM82-08	BRAKE SWITCH	GROUND
I	EM82-09	IGNITION SWITCHED POWER SUPPLY	B+
SG	EM82-10	HO2S, UPSTREAM 'A' BANK - CONSTANT	3.8 V
SG	EM82-11	HO2S, UPSTREAM 'B' BANK - CONSTANT	3.8 V
I	EM82-12	INERTIA SWITCH ACTIVATED (VEHICLE IMPACT)	GROUND
I	EM82-13	EMS SWITCHED POWER SUPPLY 2	B+
I	EM82-14	ECT FEEDBACK	0.41 V @ 90 °C; (DECREASING VOLTAGE WITH TEMPERATURE INCREASE)
D	EM82-15	OK TO START	ENCODED COMMUNICATIONS
D	EM82-16	SECURITY ACKNOWLEDGE	ENCODED COMMUNICATIONS
I	EM82-17	IATS FEEDBACK	0.98 V @ 10 °C; (DECREASING VOLTAGE WITH TEMPERATURE INCREASE)
O	EM83-03	AIR ASSIST CLOSE VALVE ACTIVATE	8 V @ IDLE (78% DUTY CYCLE)
O	EM83-05	SENSOR SUPPLY VOLTAGE 2	5 V
SG	EM83-06	SENSOR SHIELD	GROUND
SG	EM83-07	CKPS SIGNAL GROUND	GROUND
I	EM83-08	CKPS SIGNAL	5 V @ 1000 RPM = 45 Hz; 2000 RPM = 90 Hz
SG	EM83-09	CMPS, 'A' BANK SIGNAL GROUND	GROUND
SG	EM83-12	HO2S SHIELD	GROUND
SG	EM83-13	SENSORS SIGNAL GROUND 2	GROUND
I	EM83-14	KNOCK SENSOR, 'A' BANK FEEDBACK	0 kHz = NO KNOCK; 2 - 20 kHz = KNOCK
C	EM83-15	CAN NETWORK	15 - 1500 Hz
C	EM83-16	CAN NETWORK	15 - 1500 Hz
SG	EM83-17	CMPS, 'B' BANK SIGNAL GROUND	GROUND
I	EM83-18	CMPS, 'B' BANK SIGNAL	0.7 - 1 VAC @ 1000 RPM = 43 Hz; 2000 RPM = 72 Hz
I	EM83-19	CMPS, 'A' BANK SIGNAL	0.7 - 1 VAC @ 1000 RPM = 43 Hz; 2000 RPM = 72 Hz
I	EM83-20	BATTERY POWER SUPPLY	B+
I	EM83-21	HO2S, 'A' BANK DOWNSTREAM	0.1 - 0.9 V @ IDLE (SWING)
I	EM83-22	HO2S, 'B' BANK DOWNSTREAM	0.1 - 0.9 V @ IDLE (SWING)
I	EM83-23	KNOCK SENSOR, 'B' BANK FEEDBACK	0 kHz = NO KNOCK; 2 - 20 kHz = KNOCK
C	EM83-24	CAN NETWORK	15 - 1500 Hz
C	EM83-25	CAN NETWORK	15 - 1500 Hz
O	EM83-26	MAFS REFERENCE GROUND	GROUND
O	EM83-27	MAFS REFERENCE GROUND	GROUND
I	EM83-28	MAFS FEEDBACK	1.2 V @ IDLE, INCREASING WITH RPM INCREASE
I	EM84-01	GROUND (DOWNSTREAM HO2S HEATERS)	GROUND
O	EM84-07	HO2S HEATER, 'A' BANK DOWNSTREAM CONTROL	GROUND (20 - 60% DUTY CYCLE)
O	EM84-15	HO2S HEATER, 'B' BANK DOWNSTREAM CONTROL	GROUND (20 - 60% DUTY CYCLE)
I	EM84-16	GROUND (INJECTORS 1A, 2B, 3B, 4A)	GROUND
O	EM84-17	IGNITION MODULE 4B SWITCHING	GROUND (85 - 90% DUTY CYCLE @ IDLE)
I	EM84-22	GROUND (INJECTORS 1B, 2A, 3A, 4B)	GROUND
O	EM85-01	HO2S HEATER, 'A' BANK UPSTREAM CONTROL	GROUND (85 - 90% DUTY CYCLE AT IDLE)
O	EM85-02	HO2S HEATER, 'B' BANK UPSTREAM CONTROL	GROUND (85 - 90% DUTY CYCLE AT IDLE)
O	EM85-05	"COOL BOX" COOLING FAN ACTIVATE	GROUND
I	EM85-06	GROUND (HO2S A UPSTREAM HEATER)	GROUND
I	EM85-07	GROUND (HO2S B UPSTREAM HEATER)	GROUND
I	EM85-08	HO2S HEATERS OBD MONITOR	HEATERS ACTIVE = B+ V

**NOTE:** Refer to the Appendix at the rear of this book for CAN and SCP Network Messages.

The following abbreviations are used to represent values for Control Module Pin-Out data

I	Input	D	Serial and Encoded Data	B+	Battery Voltage	kHz	Frequency x 1000
O	Output	C	CAN (Network)	V	Voltage (DC)	ms	Milliseconds
SG	Signal Ground	S	SCP Network	Hz	Frequency	mV	Millivolts

**CAUTION:** The information on this data page is furnished to aid the user in understanding circuit operation. THIS INFORMATION SHOULD BE USED FOR REFERENCE ONLY.

**NOTE:** The values listed are approximately those that can be expected at the control module connector pins with all circuit connections made and all components connected and fitted. "Active" means a load is applied or a switch is ON; "Inactive" means a load is not applied or a switch is OFF.

**Fig. 04.1**

**COMPONENTS**

Component	Connector / Type / Color	Location / Access
AIR ASSIST CLOSE VALVE	PI29 / 3-WAY SUMITOMO SS / GREY	ENGINE COMPARTMENT / THROTTLE ASSEMBLY
BRAKE SWITCH	AC24 / 4-WAY MULTILOCK 070 / WHITE	TOP OF BRAKE PEDAL
CCV: CANISTER CLOSE VALVE	BT14 / 2-WAY YAZAKI 090 / BLACK	BEHIND REAR AXLE / RIGHT HAND SIDE
CKPS: CRANKSHAFT POSITION SENSOR	PI17 / 3-WAY ECONOSEAL III LC / BLACK	ENGINE / REAR OF BED PLATE
CMPS: CAMSHAFT POSITION SENSOR - A BANK	PI16 / 2-WAY YAZAKI 090 / BLACK	'A' BANK CYLINDER HEAD, REAR
CMPS: CAMSHAFT POSITION SENSOR - B BANK	PI15 / 2-WAY YAZAKI 090 / BLACK	'B' BANK CYLINDER HEAD, REAR
ECM AND TCM COOLING FAN	EM64 / 2-WAY MULTILOCK 070 / WHITE	ENGINE COMPARTMENT / CONTROL MODULE ENCLOSURE
ECTS: ENGINE COOLANT TEMPERATURE SENSOR	PI4 / 2-WAY ECONOSEAL E J2 / GREY	ENGINE COMPARTMENT / REAR OF ENGINE TOP HOSE
ENGINE CONTROL MODULE	EM80 / 31-WAY AMP 403 / NATURAL EM81 / 24-WAY AMP 403 / NATURAL EM82 / 17-WAY AMP 403 / NATURAL EM83 / 28-WAY AMP 403 / NATURAL EM84 / 22-WAY AMP 403 / NATURAL EM85 / 12-WAY MULTILOCK 070 / WHITE	ENGINE COMPARTMENT / CONTROL MODULE ENCLOSURE
EOTS: ENGINE OIL TEMPERATURE SENSOR	PI38 / 2-WAY ECONOSEAL EC J2 / GREY	ENGINE BLOCK / BELOW GENERATOR
EVAPP: EVAPORATIVE EMISSION CONTROL VALVE	LF58 / 2-WAY ECONOSEAL J2 / BLACK	BEHIND LEFT HAND WHEEL ARCH LINER
FTPS: FUEL TANK PRESSURE SENSOR	FT2 / 3-WAY ECONOSEAL III LC / BLACK	TRUNK / FUEL TANK EVAPORATIVE FLANGE
HO2S: HEATED OXYGEN SENSOR - A DOWNSTREAM	EM22 / 2-WAY SUMITOMO 090 II / BLACK	'A' BANK CATALYTIC CONVERTER
HO2S: HEATED OXYGEN SENSOR - A UPSTREAM	EM21 / 4-WAY SUMITOMO 090 II / GREY	'A' BANK CATALYTIC CONVERTER
HO2S: HEATED OXYGEN SENSOR - B DOWNSTREAM	EM24 / 2-WAY SUMITOMO 090 II / BLACK	'B' BANK CATALYTIC CONVERTER
HO2S: HEATED OXYGEN SENSOR - B UPSTREAM	EM23 / 4-WAY SUMITOMO 090 II / GREY	'B' BANK CATALYTIC CONVERTER
KS: KNOCK SENSOR - A BANK	PI26 / 2-WAY ECONOSEAL III LC / BLACK	ENGINE VEE / UNDER INTAKE MANIFOLD
KS: KNOCK SENSOR - B BANK	PI27 / 2-WAY ECONOSEAL III LC / BLACK	ENGINE VEE / UNDER INTAKE MANIFOLD
MAFS: MASS AIR FLOW SENSOR	PI35 / 5-WAY YAZAKI 0902 / BLACK	ENGINE COMPARTMENT / REARWARD OF AIR CLEANER
PARKING BRAKE SWITCH	FC19 / 1-WAY LUCAR POSILOCK / BLACK	BELOW PARKING BRAKE LEVER
PPS: PEDAL POSITION SENSORS	PI42 / 5-WAY SUMITOMO TS090 / BLACK	ENGINE COMPARTMENT / THROTTLE ASSEMBLY
THROTTLE MOTOR	PI33 / 2-WAY SUMITOMO HM250 / BLACK	ENGINE COMPARTMENT / THROTTLE ASSEMBLY
TPS: THROTTLE POSITION SENSORS	PI6 / 4-WAY ECONOSEAL J2T / BLACK	ENGINE COMPARTMENT / THROTTLE ASSEMBLY
VVT SOLENOID VALVE: VARIABLE VALVE TIMING SOLENOID VALVE - A	PI31 / 2-WAY AMP JUNIOR POWER TIMER / BLACK	ENGINE COMPARTMENT / 'A' BANK CYLINDER HEAD, FRONT
VVT SOLENOID VALVE: VARIABLE VALVE TIMING SOLENOID VALVE - B	PI32 / 2-WAY AMP JUNIOR POWER TIMER / BLACK	ENGINE COMPARTMENT / 'B' BANK CYLINDER HEAD, FRONT

**RELAYS**

Relay	Color / Stripe	Connector / Color	Location / Access
THROTTLE MOTOR POWER RELAY	BROWN	EM16 / BROWN	CONTROL MODULE ENCLOSURE RELAYS
O2S HEATERS RELAY	BROWN	EM61 / BROWN	CONTROL MODULE ENCLOSURE RELAYS

**HARNES-TO-HARNES CONNECTORS**

Connector	Type / Color	Location / Access
AC13	20-WAY MULTILOCK 070 / YELLOW	FASCIA BOTTOM CONNECTOR MOUNTING BRACKET / RIGHT HAND SIDE
BT1	20-WAY MULTILOCK 070 / WHITE	TRUNK / ABOVE RIGHT HAND REAR WHEEL ARCH
BT2	20-WAY MULTILOCK 070 / WHITE	TRUNK / ABOVE RIGHT HAND REAR WHEEL ARCH
EM1	20-WAY MULTILOCK 070 / WHITE	ENGINE COMPARTMENT / ADJACENT TO RIGHT HAND ENCLOSURE
EM2	20-WAY MULTILOCK 070 / YELLOW	ENGINE COMPARTMENT / ADJACENT TO RIGHT HAND ENCLOSURE
EM3	14-WAY MULTILOCK 070 / GREY	ENGINE COMPARTMENT / ADJACENT TO RIGHT HAND ENCLOSURE
FT1	10-WAY MULTILOCK 070 / WHITE	FUEL TANK / REAR
LF3	13-WAY ECONOSEAL III LC / WHITE	ENGINE COMPARTMENT / LEFT HAND ENCLOSURE
PI1	57-WAY SUMITOMO TS090 / BLACK	ENGINE COMPARTMENT / BRACKET ON TOP OF TRANSMISSION
PI2	13-WAY ECONOSEAL III LC / BLACK	ENGINE COMPARTMENT / BRACKET ON TOP OF TRANSMISSION
RH1	20-WAY MULTILOCK 070 / GREY	BEHIND GLOVE BOX
RH2	20-WAY MULTILOCK 070 / WHITE	REAR OF CENTER CONSOLE ASSEMBLY

**GROUNDS**

Ground	Location / Type
EM1AL	EYELET (PAIR) - LEFT HAND LEG / ENGINE COMPARTMENT, RIGHT HAND ENCLOSURE
EM1AR	EYELET (PAIR) - RIGHT HAND LEG / ENGINE COMPARTMENT, RIGHT HAND ENCLOSURE
EM1BR	EYELET (PAIR) - RIGHT HAND LEG / ENGINE COMPARTMENT, RIGHT HAND ENCLOSURE

**FOR CONTROL MODULE PIN OUT INFORMATION, UNFOLD PAGE TO LEFT.**

Refer to the front of this book for detailed information and illustrations regarding the location and identification of harnesses, relays, grounds, control modules and control module pins.

**CONTROL MODULE PIN OUT INFORMATION**

**Fig. 04.2**

**ENGINE CONTROL MODULE**

Pin	Description	Active	Inactive
O	EM80-01	EVAP VALVE ACTIVATE	GROUND (VALVE OPEN)
I	EM80-03	GROUND (POWER)	GROUND
O	EM80-04	THROTTLE MOTOR POWER SUPPLY	B+
O	EM80-05	THROTTLE MOTOR POWER SUPPLY	B+
O	EM80-06	THROTTLE MOTOR POWER SUPPLY	B+
O	EM80-07	THROTTLE MOTOR POWER SUPPLY	B+
I	EM80-08	THROTTLE MOTOR POWER SUPPLY	B+
I	EM80-09	THROTTLE MOTOR POWER SUPPLY	B+
I	EM80-15	EOT FEEDBACK	2.5 V @ 34 °C; 0.5 V @ 90 °C; (DECREASING VOLTAGE WITH TEMPERATURE INCREASE)
D	EM80-17	SERIAL COMMUNICATIONS	
D	EM80-18	SERIAL COMMUNICATIONS	
D	EM80-19	ECM PROGRAMMING	
I	EM80-21	GROUND (THROTTLE MOTOR 1)	GROUND
D	EM80-27	ECM PROGRAMMING	
I	EM80-29	GROUND (LOGIC 2)	GROUND
I	EM80-31	GROUND (THROTTLE MOTOR 2)	GROUND
O	EM81-01	VARIABLE VALVE TIMING SOLENOID + 'A' BANK	B+ (12% DUTY CYCLE @ IDLE) (INCREASING WITH ADVANCE)
O	EM81-02	VARIABLE VALVE TIMING SOLENOID - 'A' BANK	GROUND
O	EM81-03	EMS CONTROLLED RELAY ACTIVATE	GROUND
O	EM81-06	VARIABLE VALVE TIMING SOLENOID + 'B' BANK	B+ (12% DUTY CYCLE @ IDLE) (INCREASING WITH ADVANCE)
O	EM81-07	VARIABLE VALVE TIMING SOLENOID - 'B' BANK	GROUND
I	EM81-08	GROUND (POWER)	GROUND
I	EM81-09	PEDAL POSITION FEEDBACK (PPS1)	0.6 V = FOOT OFF; 3.8 V = PEDAL FULLY DEPRESSED
I	EM81-10	TPS FEEDBACK (TPS1)	0.5 V = IDLE; 4.75 V = WOT
I	EM81-12	PARK / NEUTRAL CONFIRMATION	B+ (P, N)
I	EM81-17	EMS SWITCHED POWER SUPPLY 1	B+
I	EM81-18	PEDAL POSITION FEEDBACK (PPS2)	0.8 V = FOOT OFF; 2.4 V = PEDAL FULLY DEPRESSED
I	EM81-19	TPS FEEDBACK (TPS2)	0.6 V = IDLE; 4.85 V = WOT
I	EM81-21	GROUND (LOGIC 1)	GROUND
I	EM81-22	PARKING BRAKE SWITCH	GROUND (APPLIED)
SG	EM81-24	PEDAL POSITION / THROTTLE POSITION SENSORS SHIELD	GROUND
O	EM82-01	SENSOR SUPPLY VOLTAGE 1	5 V
I	EM82-02	ENGINE CRANK	GROUND (CRANKING)
I	EM82-04	HO2S, UPSTREAM 'A' BANK - VARIABLE CURRENT (µA)	3.5 V
I	EM82-05	HO2S, UPSTREAM 'B' BANK - VARIABLE CURRENT (µA)	3.5 V
O	EM82-06	THROTTLE MOTOR POWER RELAY ACTIVATE	GROUND
SG	EM82-07	SENSORS SIGNAL GROUND 1	GROUND
I	EM82-08	BRAKE SWITCH	GROUND
I	EM82-09	IGNITION SWITCHED POWER SUPPLY	B+
SG	EM82-10	HO2S, UPSTREAM 'A' BANK - CONSTANT	3.8 V
SG	EM82-11	HO2S, UPSTREAM 'B' BANK - CONSTANT	3.8 V
I	EM82-12	INERTIA SWITCH ACTIVATED (VEHICLE IMPACT)	GROUND
I	EM82-13	EMS SWITCHED POWER SUPPLY 2	B+
I	EM82-14	ECT FEEDBACK	0.41 V @ 90 °C (DECREASING VOLTAGE WITH TEMPERATURE INCREASE)
D	EM82-15	OK TO START	ENCODED COMMUNICATIONS
D	EM82-16	SECURITY ACKNOWLEDGE	ENCODED COMMUNICATIONS
I	EM82-17	IATS FEEDBACK	0.98 V @ 10 °C (DECREASING VOLTAGE WITH TEMPERATURE INCREASE)
O	EM83-03	AIR ASSIST CLOSE VALVE ACTIVATE	8 V @ IDLE (78% DUTY CYCLE)
O	EM83-05	SENSOR SUPPLY VOLTAGE 2	5 V
SG	EM83-06	SENSOR SHIELD	GROUND
SG	EM83-07	CKPS SIGNAL GROUND	GROUND
I	EM83-08	CKPS SIGNAL	5 V @ 1000 RPM = 45 Hz; 2000 RPM = 90 Hz
SG	EM83-09	CMPS, 'A' BANK SIGNAL GROUND	GROUND
SG	EM83-12	HO2S SHIELD	GROUND
SG	EM83-13	SENSORS SIGNAL GROUND 2	GROUND
I	EM83-14	KNOCK SENSOR, 'A' BANK FEEDBACK	0 kHz = NO KNOCK, 2 - 20 kHz = KNOCK
C	EM83-15	CAN NETWORK	15 - 1500 Hz
C	EM83-16	CAN NETWORK	15 - 1500 Hz
SG	EM83-17	CMPS, 'B' BANK SIGNAL GROUND	GROUND
I	EM83-18	CMPS, 'B' BANK SIGNAL	0.7 - 1 VAC @ 1000 RPM = 43 Hz; 2000 RPM = 72 Hz
I	EM83-19	CMPS, 'A' BANK SIGNAL	0.7 - 1 VAC @ 1000 RPM = 43 Hz; 2000 RPM = 72 Hz
I	EM83-20	BATTERY POWER SUPPLY	B+
I	EM83-21	HO2S, 'A' BANK DOWNSTREAM	0.1 - 0.9 V @ IDLE (SWING)
I	EM83-22	HO2S, 'B' BANK DOWNSTREAM	0.1 - 0.9 V @ IDLE (SWING)
I	EM83-23	KNOCK SENSOR, 'B' BANK FEEDBACK	0 kHz = NO KNOCK, 2 - 20 kHz = KNOCK
C	EM83-24	CAN NETWORK	15 - 1500 Hz
C	EM83-25	CAN NETWORK	15 - 1500 Hz
O	EM83-26	MAFS REFERENCE GROUND	GROUND
O	EM83-27	MAFS REFERENCE GROUND	GROUND
I	EM83-28	MAFS FEEDBACK	1.2 V @ IDLE, INCREASING WITH RPM INCREASE
I	EM84-01	GROUND (DOWNSTREAM HO2S HEATERS)	GROUND
O	EM84-07	HO2S HEATER, 'A' BANK DOWNSTREAM CONTROL	GROUND (20 - 60% DUTY CYCLE)
O	EM84-15	HO2S HEATER, 'B' BANK DOWNSTREAM CONTROL	GROUND (20 - 60% DUTY CYCLE)
I	EM84-16	GROUND (INJECTORS 1A, 2B, 3B, 4A)	GROUND
I	EM84-22	GROUND (INJECTORS 1B, 2A, 3A, 4B)	GROUND
O	EM85-01	HO2S HEATER, 'A' BANK UPSTREAM CONTROL	GROUND (85 - 90% DUTY CYCLE AT IDLE)
O	EM85-02	HO2S HEATER, 'B' BANK UPSTREAM CONTROL	GROUND (85 - 90% DUTY CYCLE AT IDLE)
O	EM85-05	"COOL BOX" COOLING FAN ACTIVATE	GROUND
I	EM85-06	GROUND (HO2S A UPSTREAM HEATER)	GROUND
I	EM85-07	GROUND (HO2S B UPSTREAM HEATER)	GROUND
I	EM85-08	HO2S HEATERS OBD MONITOR	HEATERS ACTIVE = B+ V

**NOTE:** Refer to the Appendix at the rear of this book for CAN and SCP Network Messages.

The following abbreviations are used to represent values for Control Module Pin-Out data

I	Input	D	Serial and Encoded Data	B+	Battery Voltage	kHz	Frequency x 1000
O	Output	C	CAN (Network)	V	Voltage (DC)	ms	Milliseconds
SG	Signal Ground	S	SCP Network	Hz	Frequency	mV	Millivolts

**CAUTION:** The information on this data page is furnished to aid the user in understanding circuit operation. THIS INFORMATION SHOULD BE USED FOR REFERENCE ONLY.

**NOTE:** The values listed are approximately those that can be expected at the control module connector pins with all circuit connections made and all components connected and fitted. "Active" means a load is applied or a switch is ON; "Inactive" means a load is not applied or a switch is OFF.

**COMPONENTS**

Component	Connector / Type / Color	Location / Access
AIR ASSIST CLOSE VALVE	PI29 / 3-WAY SUMITOMO SS / GREY	ENGINE COMPARTMENT / THROTTLE ASSEMBLY
BRAKE SWITCH	AC24 / 4-WAY MULTILOCK 070 / WHITE	TOP OF BRAKE PEDAL
CKPS: CRANKSHAFT POSITION SENSOR	PI17 / 3-WAY ECONOSEAL III LC / BLACK	ENGINE / REAR OF BED PLATE
CMPS: CAMSHAFT POSITION SENSOR - A BANK	PI16 / 2-WAY YAZAKI 090 / BLACK	'A' BANK CYLINDER HEAD, REAR
CMPS: CAMSHAFT POSITION SENSOR - B BANK	PI15 / 2-WAY YAZAKI 090 / BLACK	'B' BANK CYLINDER HEAD, REAR
ECM AND TCM COOLING FAN	EM64 / 2-WAY MULTILOCK 070 / WHITE	ENGINE COMPARTMENT / CONTROL MODULE ENCLOSURE
ECTS: ENGINE COOLANT TEMPERATURE SENSOR	PI4 / 2-WAY ECONOSEAL E J2 / GREY	ENGINE COMPARTMENT / REAR OF ENGINE TOP HOSE
ENGINE CONTROL MODULE	EM80 / 31-WAY AMP 403 / NATURAL EM81 / 24-WAY AMP 403 / NATURAL EM82 / 17-WAY AMP 403 / NATURAL EM83 / 28-WAY AMP 403 / NATURAL EM84 / 22-WAY AMP 403 / NATURAL EM85 / 12-WAY MULTILOCK 070 / WHITE	ENGINE COMPARTMENT / CONTROL MODULE ENCLOSURE
EOTS: ENGINE OIL TEMPERATURE SENSOR	PI38 / 2-WAY ECONOSEAL EC J2 / GREY	ENGINE BLOACK / BELOW GENERATOR
EVAPP: EVAPORATIVE EMISSION CONTROL VALVE	LF58 / 2-WAY ECONOSEAL J2 / BLACK	BEHIND LEFT HAND WHEEL ARCH LINER
HO2S: HEATED OXYGEN SENSOR - A DOWNSTREAM	EM22 / 2-WAY SUMITOMO 090 II / BLACK	'A' BANK CATALYTIC CONVERTER
HO2S: HEATED OXYGEN SENSOR - A UPSTREAM	EM21 / 4-WAY SUMITOMO 090 II / GREY	'A' BANK CATALYTIC CONVERTER
HO2S: HEATED OXYGEN SENSOR - B DOWNSTREAM	EM24 / 2-WAY SUMITOMO 090 II / BLACK	'B' BANK CATALYTIC CONVERTER
HO2S: HEATED OXYGEN SENSOR - B UPSTREAM	EM23 / 4-WAY SUMITOMO 090 II / GREY	'B' BANK CATALYTIC CONVERTER
KS: KNOCK SENSOR - A BANK	PI26 / 2-WAY ECONOSEAL III LC / BLACK	ENGINE VEE / UNDER INTAKE MANIFOLD
KS: KNOCK SENSOR - B BANK	PI27 / 2-WAY ECONOSEAL III LC / BLACK	ENGINE VEE / UNDER INTAKE MANIFOLD
MAFS: MASS AIR FLOW SENSOR	PI35 / 5-WAY YAZAKI 0902 / BLACK	ENGINE COMPARTMENT / REARWARD OF AIR CLEANER
PARKING BRAKE SWITCH	FC19 / 1-WAY LUCAR POSILOCK / BLACK	BELOW PARKING BRAKE LEVER
PPS: PEDAL POSITION SENSORS	PI42 / 5-WAY SUMITOMO TS090 / BLACK	ENGINE COMPARTMENT / THROTTLE ASSEMBLY
THROTTLE MOTOR	PI33 / 2-WAY SUMITOMO HM250 / BLACK	ENGINE COMPARTMENT / THROTTLE ASSEMBLY
TPS: THROTTLE POSITION SENSORS	PI6 / 4-WAY ECONOSEAL J2T / BLACK	ENGINE COMPARTMENT / THROTTLE ASSEMBLY
VVT SOLENOID VALVE: VARIABLE VALVE TIMING SOLENOID VALVE - A	PI31 / 2-WAY AMP JUNIOR POWER TIMER / BLACK	ENGINE COMPARTMENT / 'A' BANK CYLINDER HEAD, FRONT
VVT SOLENOID VALVE: VARIABLE VALVE TIMING SOLENOID VALVE - B	PI32 / 2-WAY AMP JUNIOR POWER TIMER / BLACK	ENGINE COMPARTMENT / 'B' BANK CYLINDER HEAD, FRONT

**RELAYS**

Relay	Color / Stripe	Connector / Color	Location / Access
THROTTLE MOTOR POWER RELAY	BROWN	EM16 / BROWN	CONTROL MODULE ENCLOSURE RELAYS
O2S HEATERS RELAY	BROWN	EM61 / BROWN	CONTROL MODULE ENCLOSURE RELAYS

**HARNESS-TO-HARNESS CONNECTORS**

Connector	Type / Color	Location / Access
AC13	20-WAY MULTILOCK 070 / YELLOW	FASCIA BOTTOM CONNECTOR MOUNTING BRACKET / RIGHT HAND SIDE
EM1	20-WAY MULTILOCK 070 / WHITE	ENGINE COMPARTMENT / ADJACENT TO RIGHT HAND ENCLOSURE
EM2	20-WAY MULTILOCK 070 / YELLOW	ENGINE COMPARTMENT / ADJACENT TO RIGHT HAND ENCLOSURE
LF3	13-WAY ECONOSEAL III LC / WHITE	ENGINE COMPARTMENT / LEFT HAND ENCLOSURE
PI1	57-WAY SUMITOMO TS090 / BLACK	ENGINE COMPARTMENT / BRACKET ON TOP OF TRANSMISSION
PI2	13-WAY ECONOSEAL III LC / BLACK	ENGINE COMPARTMENT / BRACKET ON TOP OF TRANSMISSION

**GROUNDS**

Ground	Location / Type
EM1AL	EYELET (PAIR) - LEFT HAND LEG / ENGINE COMPARTMENT, RIGHT HAND ENCLOSURE
EM1AR	EYELET (PAIR) - RIGHT HAND LEG / ENGINE COMPARTMENT, RIGHT HAND ENCLOSURE
EM1BR	EYELET (PAIR) - RIGHT HAND LEG / ENGINE COMPARTMENT, RIGHT HAND ENCLOSURE
EM2AL	EYELET (PAIR) - LEFT HAND LEG / ENGINE COMPARTMENT, LEFT HAND ENCLOSURE
EM2AR	EYELET (PAIR) - RIGHT HAND LEG / ENGINE COMPARTMENT, LEFT HAND ENCLOSURE
EM2BR	EYELET (PAIR) - RIGHT HAND LEG / ENGINE COMPARTMENT, LEFT HAND ENCLOSURE

**FOR CONTROL MODULE PIN OUT INFORMATION, UNFOLD PAGE TO LEFT.**

Refer to the front of this book for detailed information and illustrations regarding the location and identification of harnesses, relays, grounds, control modules and control module pins.

## CONTROL MODULE PIN OUT INFORMATION

### AIR CONDITIONING CONTROL MODULE

Pin	Description	Active	Inactive
I AC1-1	COMPRESSOR CLUTCH STATUS	B+ (ON)	0 V
O AC3-1	AIR CONDITIONING ELECTRICAL LOAD SIGNAL	B+	0 V
I AC4-7	LOAD INHIBIT	0 V	B+
O AC4-9	COMPRESSOR CLUTCH ON REQUEST	B+	0 V
I AC4-17	REFRIGERANT 4-WAY PRESSURE SWITCH	0 V (2 – 30 BAR)	B+ (OUT OF ACTIVE RANGE)

### ENGINE CONTROL MODULE

Pin	Description	Active	Inactive
I EM80-10	REFRIGERANT 4-WAY PRESSURE SWITCH HIGH PRESSURE	GROUND @ 20 BAR (290 PSI)	GROUND
I EM80-11	A/CCM COMPRESSOR CLUTCH REQUEST	B+	B+
O EM80-12	ELECTRICAL LOAD INHIBIT	GROUND	GROUND
O EM80-16	CRUISE CONTROL ON STATUS LED	GROUND	B+
D EM80-17	SERIAL COMMUNICATIONS		
D EM80-18	SERIAL COMMUNICATIONS		
D EM80-19	ECM PROGRAMMING		
I EM80-20	CRUISE CONTROL BRAKE CANCEL REQUEST	GROUND	B+
I EM80-22	REFRIGERANT 4-WAY PRESSURE SWITCH HIGH PRESSURE	GROUND @ 12 BAR (174 PSI)	GROUND
I EM80-23	A/CCM ELECTRICAL LOAD REQUEST (HEATED WINDSHIELD)	B+	B+
O EM80-25	AIR CONDITIONING COMPRESSOR RELAY ACTIVATE	GROUND	GROUND
O EM81-04	PARALLEL (HIGH) SPEED FAN ACTIVATE	GROUND	B+
O EM81-05	SERIES (LOW) SPEED FAN ACTIVATE	GROUND	B+
I EM81-13	CRUISE CONTROL ON REQUEST	B+	GROUND
I EM81-14	CRUISE CONTROL SET +/-	7.3 V = (+), 8.8 V = (-)B+	
I EM81-15	CRUISE CONTROL CANCEL / RESUME	7.3 V = RESUME, 8.8 V = CANCEL B+	
I EM83-04	FUEL PUMP RELAY ACTIVATE	GROUND	B+
I EM83-10	IGNITION MODULES 1A, 2B, 3B, 4A OBD MONITOR	23 Hz @ IDLE (5 V)	
I EM83-11	IGNITION MODULES 1B, 2A, 3A, 4B OBD MONITOR	23 Hz @ IDLE (5 V)	
O EM84-02	INJECTOR 1A ACTIVATE	GROUND	B+
O EM84-03	INJECTOR 3B ACTIVATE	GROUND	B+
O EM84-04	INJECTOR 2B ACTIVATE	GROUND	B+
O EM84-05	INJECTOR 4A ACTIVATE	GROUND	B+
O EM84-06	INJECTOR 1B ACTIVATE	GROUND	B+
O EM84-09	IGNITION MODULE 4A SWITCHING	GROUND (85 – 90% DUTY CYCLE @ IDLE)	B+
O EM84-10	IGNITION MODULE 3A SWITCHING	GROUND (85 – 90% DUTY CYCLE @ IDLE)	B+
O EM84-11	IGNITION MODULE 2A SWITCHING	GROUND (85 – 90% DUTY CYCLE @ IDLE)	B+
O EM84-12	IGNITION MODULE 1A SWITCHING	GROUND (85 – 90% DUTY CYCLE @ IDLE)	B+
I EM84-13	INJECTOR 4B ACTIVATE	GROUND	B+
I EM84-14	INJECTOR 3A ACTIVATE	GROUND	B+
O EM84-17	IGNITION MODULE 4B SWITCHING	GROUND (85 – 90% DUTY CYCLE @ IDLE)	B+
O EM84-18	IGNITION MODULE 3B SWITCHING	GROUND (85 – 90% DUTY CYCLE @ IDLE)	B+
O EM84-19	IGNITION MODULE 2B SWITCHING	GROUND (85 – 90% DUTY CYCLE @ IDLE)	B+
O EM84-20	IGNITION MODULE 1B SWITCHING	GROUND (85 – 90% DUTY CYCLE @ IDLE)	B+
O EM84-21	INJECTOR 2A ACTIVATE	GROUND	B+

## Fig. 04.3

### COMPONENTS

Component	Connector / Type / Color	Location / Access
AIR CONDITIONING COMPRESSOR CLUTCH	PI36 / 1-WAY SUMITOMO 090 A-TYPE / BLACK	ENGINE COMPARTMENT / A/C COMPRESSOR
AIR CONDITIONING CONTROL MODULE	AC1 / 26-WAY MULTILOCK 47 / GREY AC2 / 16-WAY MULTILOCK 47 / GREY AC3 / 12-WAY MULTILOCK 47 / GREY AC4 / 22-WAY MULTILOCK 47 / GREY AC24 / 4-WAY MULTILOCK 070 / WHITE	A/C UNIT / RIGHT HAND SIDE
BRAKE CANCEL SWITCH	FC63 / 10-WAY AMP MQL / NATURAL	TOP OF BRAKE PEDAL
SPEED CONTROL ON / OFF SWITCH	SW3 / 3-WAY EPC / BLACK	REARWARD OF GEAR SELECTOR
SPEED CONTROL SWITCHES (STEERING WHEEL)	EM80 / 31-WAY AMP 403 / NATURAL EM81 / 24-WAY AMP 403 / NATURAL EM82 / 17-WAY AMP 403 / NATURAL EM83 / 28-WAY AMP 403 / NATURAL EM84 / 22-WAY AMP 403 / NATURAL EM85 / 12-WAY MULTILOCK 070 / WHITE	CENTER OF STEERING WHEEL ENGINE COMPARTMENT / CONTROL MODULE ENCLOSURE
ENGINE CONTROL MODULE	PI7 / 2-WAY AMP JUNIOR POWER TIMER / BLACK PI11 / 2-WAY AMP JUNIOR POWER TIMER / BLACK PI8 / 2-WAY AMP JUNIOR POWER TIMER / BLACK PI12 / 2-WAY AMP JUNIOR POWER TIMER / BLACK PI9 / 2-WAY AMP JUNIOR POWER TIMER / BLACK PI13 / 2-WAY AMP JUNIOR POWER TIMER / BLACK PI10 / 2-WAY AMP JUNIOR POWER TIMER / BLACK PI14 / 2-WAY AMP JUNIOR POWER TIMER / BLACK FT3 / 4-WAY SUMITOMO DL090 / NATURAL BT10 / 10-WAY U.T.A. FUSEBOX / NATURAL BT11 / 10-WAY U.T.A. FUSEBOX / BLACK BT12 / 10-WAY U.T.A. FUSEBOX / GREEN BT13 / 10-WAY U.T.A. FUSEBOX / BLUE BT64 / EYELET	INTAKE MANIFOLD / FUEL RAIL INTAKE MANIFOLD / FUEL RAIL INTAKE MANIFOLD / FUEL RAIL INTAKE MANIFOLD / FUEL RAIL INTAKE MANIFOLD / FUEL RAIL INTAKE MANIFOLD / FUEL RAIL INTAKE MANIFOLD / FUEL RAIL INTAKE MANIFOLD / FUEL RAIL TRUNK / TOP OF FUEL TANK TRUNK / ELECTRICAL CARRIER
FUEL INJECTOR – 1A	PI51 / 4-WAY YAZAKI / BLACK	ENGINE COMPARTMENT / CAMSHAFT COVER
FUEL INJECTOR – 1B	PI55 / 4-WAY YAZAKI / BLACK	ENGINE COMPARTMENT / CAMSHAFT COVER
FUEL INJECTOR – 2A	PI52 / 4-WAY YAZAKI / BLACK	ENGINE COMPARTMENT / CAMSHAFT COVER
FUEL INJECTOR – 2B	PI56 / 4-WAY YAZAKI / BLACK	ENGINE COMPARTMENT / CAMSHAFT COVER
FUEL INJECTOR – 3A	PI53 / 4-WAY YAZAKI / BLACK	ENGINE COMPARTMENT / CAMSHAFT COVER
FUEL INJECTOR – 3B	PI57 / 4-WAY YAZAKI / BLACK	ENGINE COMPARTMENT / CAMSHAFT COVER
FUEL INJECTOR – 3B	PI54 / 4-WAY YAZAKI / BLACK	ENGINE COMPARTMENT / CAMSHAFT COVER
FUEL INJECTOR – 4A	PI58 / 4-WAY YAZAKI / BLACK	ENGINE COMPARTMENT / CAMSHAFT COVER
FUEL INJECTOR – 4B	LF9 / 8-WAY TRW / BLACK	ADJACENT TO LEFT HAND HORN
FUEL PUMP	LF13 / 2-WAY REINSHAGEN METRI 630 / BLACK	ENGINE COMPARTMENT / FRONT
FUSE BOX – TRUNK	LF12 / 2-WAY REINSHAGEN METRI 630 / BLACK LF57 / 6-WAY ECONOSEAL III LC / BLACK	ENGINE COMPARTMENT / FRONT ENGINE COMPARTMENT / REARWARD OF RADIATOR
IGNITION COIL – 1A		
IGNITION COIL – 1B		
IGNITION COIL – 2A		
IGNITION COIL – 2B		
IGNITION COIL – 3A		
IGNITION COIL – 3B		
IGNITION COIL – 4A		
IGNITION COIL – 4B		
RADIATOR FAN CONTROL RELAY MODULE		
RADIATOR FAN – LH		
RADIATOR FAN – RH		
REFRIGERANT 4-WAY PRESSURE SWITCH		

### RELAYS

Relay	Color / Stripe	Connector / Color	Location / Access
AIR CONDITIONING COMPRESSOR CLUTCH RELAY	BROWN	EM17	LH ENCLOSURE RELAYS
FUEL INJECTION RELAY	BROWN	EM5 / BROWN	CONTROL MODULE ENCLOSURE RELAYS
FUEL PUMP RELAY (#4)	BROWN	BUS	TRUNK FUSE BOX
IGNITION COIL RELAY	BROWN	EM26 / BROWN	CONTROL MODULE ENCLOSURE RELAYS

### HARNESSTO-HARNESSTO CONNECTORS

Connector	Type / Color	Location / Access
AC12	20-WAY MULTILOCK 070 / WHITE	FASCIA TOP CONNECTOR MOUNTING BRACKET / RIGHT HAND SIDE
AC13	20-WAY MULTILOCK 070 / YELLOW	FASCIA BOTTOM CONNECTOR MOUNTING BRACKET / RIGHT HAND SIDE
BT2	20-WAY MULTILOCK 070 / WHITE	TRUNK / ABOVE RIGHT HAND REAR WHEEL ARCH
EM1	20-WAY MULTILOCK 070 / WHITE	ENGINE COMPARTMENT / ADJACENT TO RIGHT HAND ENCLOSURE
EM2	20-WAY MULTILOCK 070 / YELLOW	ENGINE COMPARTMENT / ADJACENT TO RIGHT HAND ENCLOSURE
EM3	14-WAY MULTILOCK 070 / GREY	ENGINE COMPARTMENT / ADJACENT TO RIGHT HAND ENCLOSURE
FT1	10-WAY MULTILOCK 070 / WHITE	FUEL TANK / REAR
LF3	13-WAY ECONOSEAL III LC / WHITE	ENGINE COMPARTMENT / LEFT HAND ENCLOSURE
LF40	13-WAY ECONOSEAL III LC / BLACK	ENGINE COMPARTMENT / LEFT HAND ENCLOSURE
PI1	57-WAY SUMITOMO TS090 / BLACK	ENGINE COMPARTMENT / BRACKET ON TOP OF TRANSMISSION
PI2	13-WAY ECONOSEAL III LC / BLACK	ENGINE COMPARTMENT / BRACKET ON TOP OF TRANSMISSION
RH1	20-WAY MULTILOCK 070 / GREY	BEHIND GLOVE BOX
SC3	12-WAY MULTILOCK 070 / GREY	RIGHT HAND SIDE OF STEERING COLUMN
SW1	12-WAY MULTILOCK 040 / BLACK	INSIDE STEERING COLUMN COWL
SW2	6-WAY JST / WHITE	CENTER OF STEERING WHEEL

### GROUNDS

Ground	Location / Type
BT2AL	EYELET (PAIR) – LEFT HAND LEG / TRUNK, RIGHT REAR
EM1AL	EYELET (PAIR) – LEFT HAND LEG / ENGINE COMPARTMENT, RIGHT HAND ENCLOSURE
EM1AR	EYELET (PAIR) – RIGHT HAND LEG / ENGINE COMPARTMENT, RIGHT HAND ENCLOSURE
EM2AL	EYELET (PAIR) – LEFT HAND LEG / ENGINE COMPARTMENT, LEFT HAND ENCLOSURE
EM2AR	EYELET (PAIR) – RIGHT HAND LEG / ENGINE COMPARTMENT, LEFT HAND ENCLOSURE
FC3BL	EYELET (PAIR) – LEFT HAND LEG / TRANSMISSION TUNNEL, LEFT HAND SIDE
LF2AL	EYELET (PAIR) – LEFT HAND LEG / ENGINE COMPARTMENT, FORWARD OF LEFT HAND HOOD CATCH
LF2AR	EYELET (PAIR) – RIGHT HAND LEG / ENGINE COMPARTMENT, FORWARD OF LEFT HAND HOOD CATCH
LF2BL	EYELET (PAIR) – LEFT HAND LEG / ENGINE COMPARTMENT, FORWARD OF LEFT HAND HOOD CATCH

The following abbreviations are used to represent values for Control Module Pin-Out data

I	Input	D	Serial and Encoded Data	B+	Battery Voltage	kHz	Frequency x 1000
O	Output	C	CAN (Network)	V	Voltage (DC)	ms	Milliseconds
SG	Signal Ground	S	SCP Network	Hz	Frequency	mV	Millivolts

**CAUTION:** The information on this data page is furnished to aid the user in understanding circuit operation. THIS INFORMATION SHOULD BE USED FOR REFERENCE ONLY.

**NOTE:** The values listed are approximately those that can be expected at the control module connector pins with all circuit connections made and all components connected and fitted. “Active” means a load is applied or a switch is ON; “Inactive” means a load is not applied or a switch is OFF.

FOR CONTROL MODULE PIN OUT INFORMATION, UNFOLD PAGE TO LEFT.

Refer to the front of this book for detailed information and illustrations regarding the location and identification of harnesses, relays, grounds, control modules and control module pins.

**CONTROL MODULE PIN OUT INFORMATION**

**ENGINE CONTROL MODULE**

Pin	Description	Active	Inactive
O	EM80-01	EVAP VALVE ACTIVATE	GROUND (VALVE OPEN)
O	EM80-02	CANISTER CLOSE VALVE ACTIVATE	GROUND
I	EM80-03	GROUND (POWER)	GROUND
O	EM80-04	THROTTLE MOTOR POWER SUPPLY	B+
O	EM80-05	THROTTLE MOTOR POWER SUPPLY	B+
O	EM80-06	THROTTLE MOTOR POWER SUPPLY	B+
O	EM80-07	THROTTLE MOTOR POWER SUPPLY	B+
I	EM80-08	THROTTLE MOTOR POWER SUPPLY	B+
I	EM80-09	THROTTLE MOTOR POWER SUPPLY	B+
I	EM80-15	EOT FEEDBACK	2.5 V @ 34 °C; 0.5 V @ 90 °C; (DECREASING VOLTAGE WITH TEMPERATURE INCREASE)
D	EM80-17	SERIAL COMMUNICATIONS	
D	EM80-18	SERIAL COMMUNICATIONS	
D	EM80-19	ECM PROGRAMMING	
I	EM80-21	GROUND (THROTTLE MOTOR 1)	GROUND
D	EM80-27	ECM PROGRAMMING	
I	EM80-28	MAPS FEEDBACK	1.2 V = IDLE; 3.6 V = ENGINE SWITCHED OFF
I	EM80-29	GROUND (LOGIC 2)	GROUND
I	EM80-31	GROUND (THROTTLE MOTOR 2)	GROUND
O	EM81-03	EMS CONTROLLED RELAY ACTIVATE	GROUND
I	EM81-08	GROUND (POWER)	GROUND
I	EM81-09	PEDAL POSITION FEEDBACK (PPS1)	0.6 V = FOOT OFF; 3.8 V = PEDAL FULLY DEPRESSED
I	EM81-10	TPS FEEDBACK (TPS1)	0.5 V = IDLE; 4.75 V = WOT
I	EM81-12	PARK / NEUTRAL CONFIRMATION	B+ (P, N)
I	EM81-16	FUEL TANK PRESSURE SENSOR FEEDBACK	4.9 V = LOW PRESSURE, 0.2 V = HIGH PRESSURE
I	EM81-17	EMS SWITCHED POWER SUPPLY 1	B+
I	EM81-18	PEDAL POSITION FEEDBACK (PPS2)	0.8 V = FOOT OFF; 2.4 V = PEDAL FULLY DEPRESSED
I	EM81-19	TPS FEEDBACK (TPS2)	0.6 V = IDLE; 4.85 V = WOT
I	EM81-21	GROUND (LOGIC 1)	GROUND
I	EM81-22	PARKING BRAKE SWITCH	GROUND (APPLIED)
I	EM81-23	IATS 2 FEEDBACK	2.38 V @ 20 °C, (DECREASING VOLTAGE WITH TEMPERATURE INCREASE)
SG	EM81-24	PEDAL POSITION / THROTTLE POSITION SENSORS SHIELD	GROUND
O	EM82-01	SENSOR SUPPLY VOLTAGE 1	5 V
I	EM82-02	ENGINE CRANK	GROUND (CRANKING)
I	EM82-04	HO2S, UPSTREAM 'A' BANK - VARIABLE CURRENT (µA)	3.5 V
I	EM82-05	HO2S, UPSTREAM 'B' BANK - VARIABLE CURRENT (µA)	3.5 V
O	EM82-06	THROTTLE MOTOR POWER RELAY ACTIVATE	GROUND
SG	EM82-07	SENSORS SIGNAL GROUND 1	GROUND
I	EM82-08	BRAKE SWITCH	B+
I	EM82-09	IGNITION SWITCHED POWER SUPPLY	B+
SG	EM82-10	HO2S, UPSTREAM 'A' BANK - CONSTANT	3.8 V
SG	EM82-11	HO2S, UPSTREAM 'B' BANK - CONSTANT	3.8 V
I	EM82-12	INERTIA SWITCH ACTIVATED (VEHICLE IMPACT)	GROUND
I	EM82-13	EMS SWITCHED POWER SUPPLY 2	B+
I	EM82-14	ECT FEEDBACK	0.41 V @ 90 °C; (DECREASING VOLTAGE WITH TEMPERATURE INCREASE)
D	EM82-15	OK TO START	ENCODED COMMUNICATIONS
D	EM82-16	SECURITY ACKNOWLEDGE	ENCODED COMMUNICATIONS
I	EM82-17	IATS FEEDBACK	0.98 V @ 10 °C, (DECREASING VOLTAGE WITH TEMPERATURE INCREASE)
O	EM83-05	SENSOR SUPPLY VOLTAGE 2	5 V
SG	EM83-06	SENSOR SHIELD	GROUND
SG	EM83-07	CKPS SIGNAL GROUND	GROUND
I	EM83-08	CKPS SIGNAL	5 V @ 1000 RPM = 45 Hz; 2000 RPM = 90 Hz
SG	EM83-09	CMPS, 'A' BANK SIGNAL GROUND	GROUND
SG	EM83-12	HO2S SHIELD	GROUND
SG	EM83-13	SENSORS SIGNAL GROUND 2	GROUND
I	EM83-14	KNOCK SENSOR, 'A' BANK FEEDBACK	0 kHz = NO KNOCK, 2 - 20 kHz = KNOCK
C	EM83-15	CAN NETWORK	15 - 1500 Hz
C	EM83-16	CAN NETWORK	15 - 1500 Hz
SG	EM83-17	CMPS, 'B' BANK SIGNAL GROUND	GROUND
I	EM83-18	CMPS, 'B' BANK SIGNAL	0.7 - 1 VAC @ 1000 RPM = 43 Hz; 2000 RPM = 72 Hz
I	EM83-19	CMPS, 'A' BANK SIGNAL	0.7 - 1 VAC @ 1000 RPM = 43 Hz; 2000 RPM = 72 Hz
I	EM83-20	BATTERY POWER SUPPLY	B+
I	EM83-21	HO2S, 'A' BANK DOWNSTREAM	0.1 - 0.9 V @ IDLE (SWING)
I	EM83-22	HO2S, 'B' BANK DOWNSTREAM	0.1 - 0.9 V @ IDLE (SWING)
I	EM83-23	KNOCK SENSOR, 'B' BANK FEEDBACK	0 kHz = NO KNOCK, 2 - 20 kHz = KNOCK
C	EM83-24	CAN NETWORK	15 - 1500 Hz
C	EM83-25	CAN NETWORK	15 - 1500 Hz
O	EM83-26	MAFS REFERENCE GROUND	GROUND
O	EM83-27	MAFS REFERENCE GROUND	GROUND
I	EM83-28	MAFS FEEDBACK	1.2 V @ IDLE, INCREASING WITH RPM INCREASE
I	EM84-01	GROUND (DOWNSTREAM HO2S HEATERS)	GROUND
O	EM84-07	HO2S HEATER, 'A' BANK DOWNSTREAM CONTROL	GROUND (20 - 60% DUTY CYCLE)
O	EM84-15	HO2S HEATER, 'B' BANK DOWNSTREAM CONTROL	GROUND (20 - 60% DUTY CYCLE)
I	EM84-16	GROUND (INJECTORS 1A, 2B, 3B, 4A)	GROUND
I	EM84-22	GROUND (INJECTORS 1B, 2A, 3A, 4B)	GROUND
O	EM85-01	HO2S HEATER, 'A' BANK UPSTREAM CONTROL	GROUND (85 - 90% DUTY CYCLE AT IDLE)
O	EM85-02	HO2S HEATER, 'B' BANK UPSTREAM CONTROL	GROUND (85 - 90% DUTY CYCLE AT IDLE)
O	EM85-03	EGR STEPPER MOTOR 'S1' WINDING SUPPLY	GROUND
O	EM85-04	EGR STEPPER MOTOR 'S2' WINDING SUPPLY	GROUND
O	EM85-05	"COOL BOX" COOLING FAN ACTIVATE	GROUND
I	EM85-06	GROUND (HO2S A UPSTREAM HEATER)	GROUND
I	EM85-07	GROUND (HO2S B UPSTREAM HEATER)	GROUND
I	EM85-08	HO2S HEATERS OBD MONITOR	HEATERS ACTIVE = B+ V
O	EM85-09	EGR STEPPER MOTOR 'S3' WINDING SUPPLY	GROUND
O	EM85-10	EGR STEPPER MOTOR 'S4' WINDING SUPPLY	GROUND

**NOTE:** Refer to the Appendix at the rear of this book for CAN and SCP Network Messages.

The following abbreviations are used to represent values for Control Module Pin-Out data

I	Input	D	Serial and Encoded Data	B+	Battery Voltage	kHz	Frequency x 1000
O	Output	C	CAN (Network)	V	Voltage (DC)	ms	Milliseconds
SG	Signal Ground	S	SCP Network	Hz	Frequency	mV	Millivolts

**CAUTION:** The information on this data page is furnished to aid the user in understanding circuit operation. THIS INFORMATION SHOULD BE USED FOR REFERENCE ONLY.

**NOTE:** The values listed are approximately those that can be expected at the control module connector pins with all circuit connections made and all components connected and fitted. "Active" means a load is applied or a switch is ON; "Inactive" means a load is not applied or a switch is OFF.

**Fig. 04.4**

**COMPONENTS**

Component	Connector / Type / Color	Location / Access
BRAKE SWITCH	AC24 / 4-WAY MULTILOCK 070 / WHITE	TOP OF BRAKE PEDAL
CCV: CANISTER CLOSE VALVE	BT14 / 2-WAY YAZAKI 090 / BLACK	BEHIND REAR AXLE / RIGHT HAND SIDE
CKPS: CRANKSHAFT POSITION SENSOR	P117 / 3-WAY ECONOSEAL III LC / BLACK	ENGINE / REAR OF BED PLATE
CMPS: CAMSHAFT POSITION SENSOR - A BANK	P116 / 2-WAY YAZAKI 090 / BLACK	'A' BANK CYLINDER HEAD, REAR
CMPS: CAMSHAFT POSITION SENSOR - B BANK	P115 / 2-WAY YAZAKI 090 / BLACK	'B' BANK CYLINDER HEAD, REAR
ECM AND TCM COOLING FAN	EM64 / 2-WAY MULTILOCK 070 / WHITE	ENGINE COMPARTMENT / CONTROL MODULE ENCLOSURE
ECTS: ENGINE COOLANT TEMPERATURE SENSOR	P14 / 2-WAY ECONOSEAL E J2 / GREY	ENGINE COMPARTMENT / REAR OF ENGINE TOP HOSE
EGR VALVE	P134 / 6-WAY / SUMITOMO 92 / GREY	ENGINE COMPARTMENT / REAR OF THROTTLE ASSEMBLY
ENGINE CONTROL MODULE	EM80 / 31-WAY AMP 403 / NATURAL	ENGINE COMPARTMENT / CONTROL MODULE ENCLOSURE
	EM81 / 24-WAY AMP 403 / NATURAL	
	EM82 / 17-WAY AMP 403 / NATURAL	
	EM83 / 28-WAY AMP 403 / NATURAL	
	EM84 / 22-WAY AMP 403 / NATURAL	
	EM85 / 12-WAY MULTILOCK 070 / WHITE	
EOTS: ENGINE OIL TEMPERATURE SENSOR	P138 / 2-WAY ECONOSEAL EC J2 / GREY	ENGINE BLOACK / BELOW GENERATOR
EVAPP: EVAPORATIVE EMISSION CONTROL VALVE	LF58 / 2-WAY ECONOSEAL J2 / BLACK	BEHIND LEFT HAND WHEEL ARCH LINER
FTPS: FUEL TANK PRESSURE SENSOR	FT2 / 3-WAY ECONOSEAL III LC / BLACK	TRUNK / FUEL TANK EVAPORATIVE FLANGE
HO2S: HEATED OXYGEN SENSOR - A DOWNSTREAM	EM22 / 2-WAY SUMITOMO 090 II / BLACK	'A' BANK CATALYTIC CONVERTER
HO2S: HEATED OXYGEN SENSOR - A UPSTREAM	EM21 / 4-WAY SUMITOMO 090 II / GREY	'A' BANK CATALYTIC CONVERTER
HO2S: HEATED OXYGEN SENSOR - B DOWNSTREAM	EM24 / 2-WAY SUMITOMO 090 II / BLACK	'B' BANK CATALYTIC CONVERTER
HO2S: HEATED OXYGEN SENSOR - B UPSTREAM	EM23 / 4-WAY SUMITOMO 090 II / GREY	'B' BANK CATALYTIC CONVERTER
IATS 2: INTAKE AIR TEMPERATURE SENSOR 2	P13 / 2-WAY AMP JUNIOR POWER TIMER / BLACK	ENGINE COMPARTMENT / 'A' BANK INTERCOOLER / REAR
KS: KNOCK SENSOR - A BANK	P126 / 2-WAY ECONOSEAL III LC / BLACK	ENGINE VEE / UNDER INTAKE MANIFOLD
KS: KNOCK SENSOR - B BANK	P127 / 2-WAY ECONOSEAL III LC / BLACK	ENGINE VEE / UNDER INTAKE MANIFOLD
MAFS: MASS AIR FLOW SENSOR	P135 / 5-WAY YAZAKI 0902 / BLACK	ENGINE COMPARTMENT / REARWARD OF AIR CLEANER
MAPS: MANIFOLD ABSOLUTE PRESSURE SENSOR	EM10 / 3-WAY SUMITOMO / BLACK	ENGINE COMPARTMENT / CONTROL MODULE ENCLOSURE
PPS: PEDAL POSITION SENSORS	P142 / 5-WAY SUMITOMO TS090 / BLACK	ENGINE COMPARTMENT / THROTTLE ASSEMBLY
THROTTLE MOTOR	P133 / 2-WAY SUMITOMO HM250 / BLACK	ENGINE COMPARTMENT / THROTTLE ASSEMBLY
TPS: THROTTLE POSITION SENSORS	P16 / 4-WAY ECONOSEAL J2T / BLACK	ENGINE COMPARTMENT / THROTTLE ASSEMBLY

**RELAYS**

Relay	Color / Stripe	Connector / Color	Location / Access
O2S HEATERS RELAY	BROWN	EM61 / BROWN	CONTROL MODULE ENCLOSURE RELAYS
THROTTLE MOTOR POWER RELAY	BROWN	EM16 / BROWN	CONTROL MODULE ENCLOSURE RELAYS

**HARNESSTO-HARNESSTO CONNECTORS**

Connector	Type / Color	Location / Access
AC13	20-WAY MULTILOCK 070 / YELLOW	FASCIA BOTTOM CONNECTOR MOUNTING BRACKET / RIGHT HAND SIDE
BT1	20-WAY MULTILOCK 070 / WHITE	TRUNK / ABOVE RIGHT HAND REAR WHEEL ARCH
BT2	20-WAY MULTILOCK 070 / WHITE	TRUNK / ABOVE RIGHT HAND REAR WHEEL ARCH
EM1	20-WAY MULTILOCK 070 / WHITE	ENGINE COMPARTMENT / ADJACENT TO RIGHT HAND ENCLOSURE
EM2	20-WAY MULTILOCK 070 / YELLOW	ENGINE COMPARTMENT / ADJACENT TO RIGHT HAND ENCLOSURE
EM3	14-WAY MULTILOCK 070 / GREY	ENGINE COMPARTMENT / ADJACENT TO RIGHT HAND ENCLOSURE
FT1	10-WAY MULTILOCK 070 / WHITE	FUEL TANK / REAR
LF3	13-WAY ECONOSEAL III LC / WHITE	ENGINE COMPARTMENT / LEFT HAND ENCLOSURE
PI1	57-WAY SUMITOMO TS090 / BLACK	ENGINE COMPARTMENT / BRACKET ON TOP OF TRANSMISSION
PI2	13-WAY ECONOSEAL III LC / BLACK	ENGINE COMPARTMENT / BRACKET ON TOP OF TRANSMISSION
RH1	20-WAY MULTILOCK 070 / GREY	BEHIND GLOVE BOX
RH2	20-WAY MULTILOCK 070 / WHITE	REAR OF CENTER CONSOLE ASSEMBLY

**GROUND**

Ground	Location / Type
EM1AL	EYELET (PAIR) - LEFT HAND LEG / ENGINE COMPARTMENT, RIGHT HAND ENCLOSURE
EM1AR	EYELET (PAIR) - RIGHT HAND LEG / ENGINE COMPARTMENT, RIGHT HAND ENCLOSURE
EM1BR	EYELET (PAIR) - RIGHT HAND LEG / ENGINE COMPARTMENT, RIGHT HAND ENCLOSURE

**FOR CONTROL MODULE PIN OUT INFORMATION, UNFOLD PAGE TO LEFT.**

Refer to the front of this book for detailed information and illustrations regarding the location and identification of harnesses, relays, grounds, control modules and control module pins.

**CONTROL MODULE PIN OUT INFORMATION**

**ENGINE CONTROL MODULE**

Pin	Description	Active	Inactive
O	EM80-01	EVAP VALVE ACTIVATE	B+
I	EM80-03	GROUND (POWER)	GROUND
O	EM80-04	THROTTLE MOTOR POWER SUPPLY	B+
O	EM80-05	THROTTLE MOTOR POWER SUPPLY	B+
O	EM80-06	THROTTLE MOTOR POWER SUPPLY	B+
O	EM80-07	THROTTLE MOTOR POWER SUPPLY	B+
I	EM80-08	THROTTLE MOTOR POWER SUPPLY	B+
I	EM80-09	THROTTLE MOTOR POWER SUPPLY	B+
I	EM80-15	EOT FEEDBACK	2.5 V @ 34 °C; 0.5 V @ 90 °C; (DECREASING VOLTAGE WITH TEMPERATURE INCREASE)
D	EM80-17	SERIAL COMMUNICATIONS	
D	EM80-18	SERIAL COMMUNICATIONS	
D	EM80-19	ECM PROGRAMMING	
I	EM80-21	GROUND (THROTTLE MOTOR 1)	GROUND
D	EM80-27	ECM PROGRAMMING	
I	EM80-29	GROUND (LOGIC 2)	GROUND
I	EM80-31	GROUND (THROTTLE MOTOR 2)	GROUND
O	EM81-03	EMS CONTROLLED RELAY ACTIVATE	B+
I	EM81-08	GROUND (POWER)	GROUND
I	EM81-09	PEDAL POSITION FEEDBACK (PPS/1)	0.6 V = FOOT OFF; 3.8 V = PEDAL FULLY DEPRESSED
I	EM81-10	TPS FEEDBACK (TPS/1)	0.5 V = IDLE; 4.75 V = WOT
I	EM81-12	PARK / NEUTRAL CONFIRMATION	B+ (P, N)
I	EM81-17	EMS SWITCHED POWER SUPPLY 1	B+
I	EM81-18	PEDAL POSITION FEEDBACK (PPS/2)	0.8 V = FOOT OFF; 2.4 V = PEDAL FULLY DEPRESSED
I	EM81-19	TPS FEEDBACK (TPS/2)	0.6 V = IDLE; 4.85 V = WOT
I	EM81-21	GROUND (LOGIC 1)	GROUND
I	EM81-22	PARKING BRAKE SWITCH	GROUND (APPLIED)
I	EM81-23	IATS 2 FEEDBACK	2.38 V @ 20 °C; (DECREASING VOLTAGE WITH TEMPERATURE INCREASE)
SG	EM81-24	PEDAL POSITION / THROTTLE POSITION SENSORS SHIELD	GROUND
O	EM82-01	SENSOR SUPPLY VOLTAGE 1	5 V
I	EM82-02	ENGINE CRANK	GROUND (CRANKING)
I	EM82-04	HO2S, UPSTREAM 'A' BANK - VARIABLE CURRENT (µA)	3.5 V
I	EM82-05	HO2S, UPSTREAM 'B' BANK - VARIABLE CURRENT (µA)	3.5 V
O	EM82-06	THROTTLE MOTOR POWER RELAY ACTIVATE	GROUND
SG	EM82-07	SENSORS SIGNAL GROUND 1	GROUND
I	EM82-08	BRAKE SWITCH	GROUND
I	EM82-09	IGNITION SWITCHED POWER SUPPLY	B+
SG	EM82-10	HO2S, UPSTREAM 'A' BANK - CONSTANT	3.8 V
SG	EM82-11	HO2S, UPSTREAM 'B' BANK - CONSTANT	3.8 V
I	EM82-12	INERTIA SWITCH ACTIVATED (VEHICLE IMPACT)	GROUND
I	EM82-13	EMS SWITCHED POWER SUPPLY 2	B+
I	EM82-14	ECT FEEDBACK	0.41 V @ 90 °C; (DECREASING VOLTAGE WITH TEMPERATURE INCREASE)
D	EM82-15	OK TO START	ENCODED COMMUNICATIONS
D	EM82-16	SECURITY ACKNOWLEDGE	ENCODED COMMUNICATIONS
I	EM82-17	IATS FEEDBACK	0.98 V @ 10 °C; (DECREASING VOLTAGE WITH TEMPERATURE INCREASE)
O	EM83-05	SENSOR SUPPLY VOLTAGE 2	5 V
SG	EM83-06	SENSOR SHIELD	GROUND
SG	EM83-07	CKPS SIGNAL GROUND	GROUND
I	EM83-08	CKPS SIGNAL	5 V @ 1000 RPM = 45 Hz; 2000 RPM = 90 Hz
SG	EM83-09	CMPS, 'A' BANK SIGNAL GROUND	GROUND
SG	EM83-12	HO2S SHIELD	GROUND
SG	EM83-13	SENSORS SIGNAL GROUND 2	GROUND
I	EM83-14	KNOCK SENSOR, 'A' BANK FEEDBACK	0 kHz = NO KNOCK, 2 - 20 kHz = KNOCK
C	EM83-15	CAN NETWORK	15 - 1500 Hz
C	EM83-16	CAN NETWORK	15 - 1500 Hz
SG	EM83-17	CMPS, 'B' BANK SIGNAL GROUND	GROUND
I	EM83-18	CMPS, 'B' BANK SIGNAL	0.7 - 1 VAC @ 1000 RPM = 43 Hz; 2000 RPM = 72 Hz
I	EM83-19	CMPS, 'A' BANK SIGNAL	0.7 - 1 VAC @ 1000 RPM = 43 Hz; 2000 RPM = 72 Hz
I	EM83-20	BATTERY POWER SUPPLY	B+
I	EM83-21	HO2S, 'A' BANK DOWNSTREAM	0.1 - 0.9 V @ IDLE (SWING)
I	EM83-22	HO2S, 'B' BANK DOWNSTREAM	0.1 - 0.9 V @ IDLE (SWING)
I	EM83-23	KNOCK SENSOR, 'B' BANK FEEDBACK	0 kHz = NO KNOCK, 2 - 20 kHz = KNOCK
C	EM83-24	CAN NETWORK	15 - 1500 Hz
C	EM83-25	CAN NETWORK	15 - 1500 Hz
O	EM83-26	MAFS REFERENCE GROUND	GROUND
O	EM83-27	MAFS REFERENCE GROUND	GROUND
I	EM83-28	MAFS FEEDBACK	1.2 V @ IDLE, INCREASING WITH RPM INCREASE
I	EM84-01	GROUND (DOWNSTREAM HO2S HEATERS)	GROUND
O	EM84-07	HO2S HEATER, 'A' BANK DOWNSTREAM CONTROL	GROUND (20 - 60% DUTY CYCLE)
O	EM84-15	HO2S HEATER, 'B' BANK DOWNSTREAM CONTROL	GROUND (20 - 60% DUTY CYCLE)
I	EM84-16	GROUND (INJECTORS 1A, 2B, 3B, 4A)	GROUND
I	EM84-22	GROUND (INJECTORS 1B, 2A, 3A, 4B)	GROUND
O	EM85-01	HO2S HEATER, 'A' BANK UPSTREAM CONTROL	GROUND (85 - 90% DUTY CYCLE AT IDLE)
O	EM85-02	HO2S HEATER, 'B' BANK UPSTREAM CONTROL	GROUND (85 - 90% DUTY CYCLE AT IDLE)
O	EM85-05	"COOL BOX" COOLING FAN ACTIVATE	GROUND
I	EM85-06	GROUND (HO2S A UPSTREAM HEATER)	GROUND
I	EM85-07	GROUND (HO2S B UPSTREAM HEATER)	GROUND
I	EM85-08	HO2S HEATERS OBD MONITOR	HEATERS ACTIVE = B+ V

**NOTE:** Refer to the Appendix at the rear of this book for CAN and SCP Network Messages.

The following abbreviations are used to represent values for Control Module Pin-Out data

I	Input	D	Serial and Encoded Data	B+	Battery Voltage	kHz	Frequency x 1000
O	Output	C	CAN (Network)	V	Voltage (DC)	ms	Milliseconds
SG	Signal Ground	S	SCP Network	Hz	Frequency	mV	Millivolts

**CAUTION:** The information on this data page is furnished to aid the user in understanding circuit operation. THIS INFORMATION SHOULD BE USED FOR REFERENCE ONLY.

**NOTE:** The values listed are approximately those that can be expected at the control module connector pins with all circuit connections made and all components connected and fitted. "Active" means a load is applied or a switch is ON; "Inactive" means a load is not applied or a switch is OFF.

**Fig. 04.5**

**COMPONENTS**

Component	Connector / Type / Color	Location / Access
BRAKE SWITCH	AC24 / 4-WAY MULTILOCK 070 / WHITE	TOP OF BRAKE PEDAL
CKPS: CRANKSHAFT POSITION SENSOR	PI17 / 3-WAY ECONOSEAL III LC / BLACK	ENGINE / REAR OF BED PLATE
CMPS: CAMSHAFT POSITION SENSOR - A BANK	PI16 / 2-WAY YAZAKI 090 / BLACK	'A' BANK CYLINDER HEAD, REAR
CMPS: CAMSHAFT POSITION SENSOR - B BANK	PI15 / 2-WAY YAZAKI 090 / BLACK	'B' BANK CYLINDER HEAD, REAR
ECM AND TCM COOLING FAN	EM64 / 2-WAY MULTILOCK 070 / WHITE	ENGINE COMPARTMENT / CONTROL MODULE ENCLOSURE
ECTS: ENGINE COOLANT TEMPERATURE SENSOR	PI4 / 2-WAY ECONOSEAL E J2 / GREY	ENGINE COMPARTMENT / REAR OF ENGINE TOP HOSE
ENGINE CONTROL MODULE	EM80 / 31-WAY AMP 403 / NATURAL EM81 / 24-WAY AMP 403 / NATURAL EM82 / 17-WAY AMP 403 / NATURAL EM83 / 28-WAY AMP 403 / NATURAL EM84 / 22-WAY AMP 403 / NATURAL EM85 / 12-WAY MULTILOCK 070 / WHITE	ENGINE COMPARTMENT / CONTROL MODULE ENCLOSURE
EOTS: ENGINE OIL TEMPERATURE SENSOR	PI38 / 2-WAY ECONOSEAL EC J2 / GREY	ENGINE BLOACK / BELOW GENERATOR
EVAPP: EVAPORATIVE EMISSION CONTROL VALVE	LF58 / 2-WAY ECONOSEAL J2 / BLACK	BEHIND LEFT HAND WHEEL ARCH LINER
HO2S: HEATED OXYGEN SENSOR - A DOWNSTREAM	EM22 / 2-WAY SUMITOMO 090 II / BLACK	'A' BANK CATALYTIC CONVERTER
HO2S: HEATED OXYGEN SENSOR - A UPSTREAM	EM21 / 4-WAY SUMITOMO 090 II / GREY	'A' BANK CATALYTIC CONVERTER
HO2S: HEATED OXYGEN SENSOR - B DOWNSTREAM	EM24 / 2-WAY SUMITOMO 090 II / BLACK	'B' BANK CATALYTIC CONVERTER
HO2S: HEATED OXYGEN SENSOR - B UPSTREAM	EM23 / 4-WAY SUMITOMO 090 II / GREY	'B' BANK CATALYTIC CONVERTER
IATS 2: INTAKE AIR TEMPERATURE SENSOR 2	PI3 / 2-WAY AMP JUNIOR POWER TIMER / BLACK	ENGINE COMPARTMENT / 'A' BANK INTERCOOLER / REAR
KS: KNOCK SENSOR - A BANK	PI26 / 2-WAY ECONOSEAL III LC / BLACK	ENGINE VEE / UNDER INTAKE MANIFOLD
KS: KNOCK SENSOR - B BANK	PI27 / 2-WAY ECONOSEAL III LC / BLACK	ENGINE VEE / UNDER INTAKE MANIFOLD
MAFS: MASS AIR FLOW SENSOR	PI35 / 5-WAY YAZAKI 0902 / BLACK	ENGINE COMPARTMENT / REARWARD OF AIR CLEANER
PPS: PEDAL POSITION SENSORS	PI42 / 5-WAY SUMITOMO TS090 / BLACK	ENGINE COMPARTMENT / THROTTLE ASSEMBLY
THROTTLE MOTOR	PI33 / 2-WAY SUMITOMO HM250 / BLACK	ENGINE COMPARTMENT / THROTTLE ASSEMBLY
TPS: THROTTLE POSITION SENSORS	PI6 / 4-WAY ECONOSEAL J2T / BLACK	ENGINE COMPARTMENT / THROTTLE ASSEMBLY

**RELAYS**

Relay	Color / Stripe	Connector / Color	Location / Access
O2S HEATERS RELAY	BROWN	EM61 / BROWN	CONTROL MODULE ENCLOSURE RELAYS
THROTTLE MOTOR POWER RELAY	BROWN	EM16 / BROWN	CONTROL MODULE ENCLOSURE RELAYS

**HARNESSTO-HARNESSTO CONNECTORS**

Connector	Type / Color	Location / Access
AC13	20-WAY MULTILOCK 070 / YELLOW	FASCIA BOTTOM CONNECTOR MOUNTING BRACKET / RIGHT HAND SIDE
EM1	20-WAY MULTILOCK 070 / WHITE	ENGINE COMPARTMENT / ADJACENT TO RIGHT HAND ENCLOSURE
EM2	20-WAY MULTILOCK 070 / YELLOW	ENGINE COMPARTMENT / ADJACENT TO RIGHT HAND ENCLOSURE
LF3	13-WAY ECONOSEAL III LC / WHITE	ENGINE COMPARTMENT / LEFT HAND ENCLOSURE
PI1	57-WAY SUMITOMO TS090 / BLACK	ENGINE COMPARTMENT / BRACKET ON TOP OF TRANSMISSION
PI2	13-WAY ECONOSEAL III LC / BLACK	ENGINE COMPARTMENT / BRACKET ON TOP OF TRANSMISSION

**GROUNDS**

Ground	Location / Type
EM1AL	EYELET (PAIR) - LEFT HAND LEG / ENGINE COMPARTMENT, RIGHT HAND ENCLOSURE
EM1AR	EYELET (PAIR) - RIGHT HAND LEG / ENGINE COMPARTMENT, RIGHT HAND ENCLOSURE
EM1BR	EYELET (PAIR) - RIGHT HAND LEG / ENGINE COMPARTMENT, RIGHT HAND ENCLOSURE
EM2AL	EYELET (PAIR) - LEFT HAND LEG / ENGINE COMPARTMENT, LEFT HAND ENCLOSURE
EM2AR	EYELET (PAIR) - RIGHT HAND LEG / ENGINE COMPARTMENT, LEFT HAND ENCLOSURE
EM2BR	EYELET (PAIR) - RIGHT HAND LEG / ENGINE COMPARTMENT, LEFT HAND ENCLOSURE

**FOR CONTROL MODULE PIN OUT INFORMATION, UNFOLD PAGE TO LEFT.**

Refer to the front of this book for detailed information and illustrations regarding the location and identification of harnesses, relays, grounds, control modules and control module pins.

## CONTROL MODULE PIN OUT INFORMATION

### AIR CONDITIONING CONTROL MODULE

Pin	Description	Active	Inactive
I	AC1-1 COMPRESSOR CLUTCH STATUS	B+ (ON)	0 V
O	AC3-1 AIR CONDITIONING ELECTRICAL LOAD SIGNAL	B+	0 V
I	AC4-7 LOAD INHIBIT	0 V	B+
O	AC4-9 COMPRESSOR CLUTCH ON REQUEST	B+	0 V
I	AC4-17 REFRIGERANT 4-WAY PRESSURE SWITCH	0 V (2 - 30 BAR)	B+ (OUT OF ACTIVE RANGE)

### ENGINE CONTROL MODULE

Pin	Description	Active	Inactive
I	EM80-10 REFRIGERANT 4-WAY PRESSURE SWITCH HIGH PRESSURE	GROUND @ 20 BAR (290 PSI)	GROUND
I	EM80-11 AICCM COMPRESSOR CLUTCH REQUEST	B+	B+
O	EM80-12 ELECTRICAL LOAD INHIBIT	GROUND	B+
O	EM80-14 INTERCOOLER PUMP RELAY ACTIVATE	GROUND	B+
O	EM80-16 CRUISE CONTROL ON STATUS LED	GROUND	B+
I	EM80-20 CRUISE CONTROL BRAKE CANCEL REQUEST	GROUND	B+
I	EM80-22 REFRIGERANT 4-WAY PRESSURE SWITCH HIGH PRESSURE	GROUND @ 12 BAR (174 PSI)	GROUND
I	EM80-23 AICCM ELECTRICAL LOAD REQUEST (HEATED WINDSHIELD)	B+	B+
O	EM80-25 AIR CONDITIONING COMPRESSOR RELAY ACTIVATE	GROUND	B+
O	EM81-04 PARALLEL (HIGH) SPEED FAN ACTIVATE	GROUND	B+
O	EM81-05 SERIES (LOW) SPEED FAN ACTIVATE	GROUND	B+
I	EM81-13 CRUISE CONTROL ON REQUEST	B+	GROUND
I	EM81-14 CRUISE CONTROL SET +/-	7.3 V = (+), 8.8 V = (-)B+	
I	EM81-15 CRUISE CONTROL CANCEL / RESUME	7.3 V = RESUME, 8.8 V = CANCEL B+	
O	EM82-03 FUEL PUMP RELAY 2 ACTIVATE	GROUND	B+
I	EM83-04 FUEL PUMP RELAY ACTIVATE	GROUND	B+
I	EM83-10 IGNITION MODULES 1A, 2B, 3B, 4A OBD MONITOR	23 Hz @ IDLE (5 V)	
I	EM83-11 IGNITION MODULES 1B, 2A, 3A, 4B OBD MONITOR	23 Hz @ IDLE (5 V)	
O	EM84-02 INJECTOR 1A ACTIVATE	GROUND	B+
O	EM84-03 INJECTOR 3B ACTIVATE	GROUND	B+
O	EM84-04 INJECTOR 2B ACTIVATE	GROUND	B+
O	EM84-05 INJECTOR 4A ACTIVATE	GROUND	B+
O	EM84-06 INJECTOR 1B ACTIVATE	GROUND	B+
O	EM84-09 IGNITION MODULE 4A SWITCHING	GROUND (85 - 90% DUTY CYCLE @ IDLE)	B+
O	EM84-10 IGNITION MODULE 3A SWITCHING	GROUND (85 - 90% DUTY CYCLE @ IDLE)	B+
O	EM84-11 IGNITION MODULE 2A SWITCHING	GROUND (85 - 90% DUTY CYCLE @ IDLE)	B+
O	EM84-12 IGNITION MODULE 1A SWITCHING	GROUND (85 - 90% DUTY CYCLE @ IDLE)	B+
I	EM84-13 INJECTOR 4B ACTIVATE	GROUND	B+
I	EM84-14 INJECTOR 3A ACTIVATE	GROUND	B+
O	EM84-17 IGNITION MODULE 4B SWITCHING	GROUND (85 - 90% DUTY CYCLE @ IDLE)	B+
O	EM84-18 IGNITION MODULE 3B SWITCHING	GROUND (85 - 90% DUTY CYCLE @ IDLE)	B+
O	EM84-19 IGNITION MODULE 2B SWITCHING	GROUND (85 - 90% DUTY CYCLE @ IDLE)	B+
O	EM84-20 IGNITION MODULE 1B SWITCHING	GROUND (85 - 90% DUTY CYCLE @ IDLE)	B+
O	EM84-21 INJECTOR 2A ACTIVATE	GROUND	B+

## Fig. 04.6

### COMPONENTS

Component	Connector / Type / Color	Location / Access
AIR CONDITIONING COMPRESSOR CLUTCH	PI36 / 1-WAY SUMITOMO 090 A-TYPE / BLACK	ENGINE COMPARTMENT / A/C COMPRESSOR
AIR CONDITIONING CONTROL MODULE	AC1 / 26-WAY MULTILOCK 47 / GREY AC2 / 16-WAY MULTILOCK 47 / GREY AC3 / 12-WAY MULTILOCK 47 / GREY AC4 / 22-WAY MULTILOCK 47 / GREY AC24 / 4-WAY MULTILOCK 070 / WHITE	A/C UNIT / RIGHT HAND SIDE
BRAKE CANCEL SWITCH	FC63 / 10-WAY AMP MQL / NATURAL	TOP OF BRAKE PEDAL
SPEED CONTROL ON / OFF SWITCH	SW3 / 3-WAY EPC / BLACK	REARWARD OF GEAR SELECTOR
SPEED CONTROL SWITCHES (STEERING WHEEL)	EM80 / 31-WAY AMP 403 / NATURAL EM81 / 24-WAY AMP 403 / NATURAL EM82 / 17-WAY AMP 403 / NATURAL EM83 / 28-WAY AMP 403 / NATURAL EM84 / 22-WAY AMP 403 / NATURAL EM85 / 12-WAY MULTILOCK 070 / WHITE	CENTER OF STEERING WHEEL ENGINE COMPARTMENT / CONTROL MODULE ENCLOSURE
ENGINE CONTROL MODULE	IJ3 / 2-WAY AMP JUNIOR POWER TIMER / BLACK IJ7 / 2-WAY AMP JUNIOR POWER TIMER / BLACK IJ4 / 2-WAY AMP JUNIOR POWER TIMER / BLACK IJ8 / 2-WAY AMP JUNIOR POWER TIMER / BLACK IJ5 / 2-WAY AMP JUNIOR POWER TIMER / BLACK IJ9 / 2-WAY AMP JUNIOR POWER TIMER / BLACK IJ6 / 2-WAY AMP JUNIOR POWER TIMER / BLACK IJ10 / 2-WAY AMP JUNIOR POWER TIMER / BLACK	INTAKE MANIFOLD / FUEL RAIL INTAKE MANIFOLD / FUEL RAIL INTAKE MANIFOLD / FUEL RAIL INTAKE MANIFOLD / FUEL RAIL INTAKE MANIFOLD / FUEL RAIL INTAKE MANIFOLD / FUEL RAIL INTAKE MANIFOLD / FUEL RAIL INTAKE MANIFOLD / FUEL RAIL
FUEL INJECTOR - 1A	FT3 / 4-WAY SUMITOMO DL090 / NATURAL	TRUNK / TOP OF FUEL TANK
FUEL INJECTOR - 1B	BT10 / 10-WAY U.T.A. FUSEBOX / NATURAL	
FUEL INJECTOR - 2A	BT11 / 10-WAY U.T.A. FUSEBOX / BLACK	
FUEL INJECTOR - 2B	BT12 / 10-WAY U.T.A. FUSEBOX / GREEN	
FUEL INJECTOR - 3A	BT13 / 10-WAY U.T.A. FUSEBOX / BLUE	
FUEL INJECTOR - 3B	BT64 / EYELET	
FUEL INJECTOR - 4A	PI51 / 4-WAY YAZAKI / BLACK	ENGINE COMPARTMENT / CAMSHAFT COVER
FUEL INJECTOR - 4B	PI55 / 4-WAY YAZAKI / BLACK	ENGINE COMPARTMENT / CAMSHAFT COVER
FUEL PUMPS	PI52 / 4-WAY YAZAKI / BLACK	ENGINE COMPARTMENT / CAMSHAFT COVER
FUSE BOX - TRUNK	PI56 / 4-WAY YAZAKI / BLACK	ENGINE COMPARTMENT / CAMSHAFT COVER
	PI53 / 4-WAY YAZAKI / BLACK	ENGINE COMPARTMENT / CAMSHAFT COVER
	PI57 / 4-WAY YAZAKI / BLACK	ENGINE COMPARTMENT / CAMSHAFT COVER
	PI54 / 4-WAY YAZAKI / BLACK	ENGINE COMPARTMENT / CAMSHAFT COVER
	PI58 / 4-WAY YAZAKI / BLACK	ENGINE COMPARTMENT / CAMSHAFT COVER
IGNITION COIL - 1A	EM75 / 2-WAY AUGAT 1.6 / BLACK	ENGINE COMPARTMENT / BELOW AIR CLEANER
IGNITION COIL - 1B	LF9 / 8-WAY TRW / BLACK	ADJACENT TO LEFT HAND HORN
IGNITION COIL - 2A	LF13 / 2-WAY REINSHAGEN METRI 630 / BLACK	ENGINE COMPARTMENT / FRONT
IGNITION COIL - 2B	LF12 / 2-WAY REINSHAGEN METRI 630 / BLACK	ENGINE COMPARTMENT / FRONT
IGNITION COIL - 3A	LF57 / 6-WAY ECONOSEAL III LC / BLACK	ENGINE COMPARTMENT / REARWARD OF RADIATOR
IGNITION COIL - 3B		
IGNITION COIL - 4A		
IGNITION COIL - 4B		
INTERCOOLER PUMP		
RADIATOR FAN CONTROL RELAY MODULE		
RADIATOR FAN - LH		
RADIATOR FAN - RH		
REFRIGERANT 4-WAY PRESSURE SWITCH		

### RELAYS

Relay	Color / Stripe	Connector / Color	Location / Access
AIR CONDITIONING COMPRESSOR CLUTCH RELAY	BROWN	EM17	LH ENCLOSURE RELAYS
FUEL INJECTION RELAY	BROWN	EM5 / BROWN	CONTROL MODULE ENCLOSURE RELAYS
FUEL PUMP 1 RELAY (#4)	BROWN	BUS	TRUNK FUSE BOX
FUEL PUMP 2 RELAY	BROWN	BT51 / BROWN	TRUNK RELAYS
IGNITION COIL RELAY	BROWN	EM26 / BROWN	CONTROL MODULE ENCLOSURE RELAYS
INTERCOOLER PUMP RELAY	BROWN	EM31 / BROWN	LHD: CONTROL MODULE ENCLOSURE RELAYS RHD: RH ENCLOSURE RELAYS

### HARNESS-TO-HARNESS CONNECTORS

Connector	Type / Color	Location / Access
AC12	20-WAY MULTILOCK 070 / WHITE	FASCIA TOP CONNECTOR MOUNTING BRACKET / RIGHT HAND SIDE
AC13	20-WAY MULTILOCK 070 / YELLOW	FASCIA BOTTOM CONNECTOR MOUNTING BRACKET / RIGHT HAND SIDE
BT2	20-WAY MULTILOCK 070 / WHITE	TRUNK / ABOVE RIGHT HAND REAR WHEEL ARCH
EM1	20-WAY MULTILOCK 070 / WHITE	ENGINE COMPARTMENT / ADJACENT TO RIGHT HAND ENCLOSURE
EM2	20-WAY MULTILOCK 070 / YELLOW	ENGINE COMPARTMENT / ADJACENT TO RIGHT HAND ENCLOSURE
EM3	14-WAY MULTILOCK 070 / GREY	ENGINE COMPARTMENT / ADJACENT TO RIGHT HAND ENCLOSURE
FT1	10-WAY MULTILOCK 070 / WHITE	FUEL TANK / REAR
LF3	13-WAY ECONOSEAL III LC / WHITE	ENGINE COMPARTMENT / LEFT HAND ENCLOSURE
LF40	13-WAY ECONOSEAL III LC / BLACK	ENGINE COMPARTMENT / LEFT HAND ENCLOSURE
PI1	57-WAY SUMITOMO TS090 / BLACK	ENGINE COMPARTMENT / BRACKET ON TOP OF TRANSMISSION
PI2	13-WAY ECONOSEAL III LC / BLACK	ENGINE COMPARTMENT / BRACKET ON TOP OF TRANSMISSION
RH1	20-WAY MULTILOCK 070 / GREY	BEHIND GLOVE BOX
RH2	20-WAY MULTILOCK 070 / WHITE	REAR OF CENTER CONSOLE ASSEMBLY
SC3	12-WAY MULTILOCK 070 / GREY	RIGHT HAND SIDE OF STEERING COLUMN
SW1	12-WAY MULTILOCK 040 / BLACK	INSIDE STEERING COLUMN COWL
SW2	6-WAY JST / WHITE	CENTER OF STEERING WHEEL

### GROUND

Ground	Location / Type
BT2AL	EYELET (PAIR) - LEFT HAND LEG / TRUNK, RIGHT REAR
EM1AL	EYELET (PAIR) - LEFT HAND LEG / ENGINE COMPARTMENT, RIGHT HAND ENCLOSURE
EM1AR	EYELET (PAIR) - RIGHT HAND LEG / ENGINE COMPARTMENT, RIGHT HAND ENCLOSURE
EM2AL	EYELET (PAIR) - LEFT HAND LEG / ENGINE COMPARTMENT, LEFT HAND ENCLOSURE
EM2AR	EYELET (PAIR) - RIGHT HAND LEG / ENGINE COMPARTMENT, LEFT HAND ENCLOSURE
FC3BL	EYELET (PAIR) - LEFT HAND LEG / TRANSMISSION TUNNEL, LEFT HAND SIDE
LF2AL	EYELET (PAIR) - LEFT HAND LEG / ENGINE COMPARTMENT, FORWARD OF LEFT HAND HOOD CATCH
LF2AR	EYELET (PAIR) - RIGHT HAND LEG / ENGINE COMPARTMENT, FORWARD OF LEFT HAND HOOD CATCH
LF2BL	EYELET (PAIR) - LEFT HAND LEG / ENGINE COMPARTMENT, FORWARD OF LEFT HAND HOOD CATCH

The following abbreviations are used to represent values for Control Module Pin-Out data

I	Input	D	Serial and Encoded Data	B+	Battery Voltage	kHz	Frequency x 1000
O	Output	C	CAN (Network)	V	Voltage (DC)	ms	Milliseconds
SG	Signal Ground	S	SCP Network	H	Voltage	mV	Millivolts

**CAUTION:** The information on this data page is furnished to aid the user in understanding circuit operation. THIS INFORMATION SHOULD BE USED FOR REFERENCE ONLY.

**NOTE:** The values listed are approximately those that can be expected at the control module connector pins with all circuit connections made and all components connected and fitted. "Active" means a load is applied or a switch is ON; "Inactive" means a load is not applied or a switch is OFF.

FOR CONTROL MODULE PIN OUT INFORMATION, UNFOLD PAGE TO LEFT.

Refer to the front of this book for detailed information and illustrations regarding the location and identification of harnesses, relays, grounds, control modules and control module pins.

**CONTROL MODULE PIN OUT INFORMATION**

**GEAR SELECTOR ILLUMINATION MODULE**

Pin	Description	Active	Inactive
I FC88-1	IGNITION SWITCHED POWER SUPPLY	B+	GROUND
C FC88-3	CAN NETWORK	15 – 1500 Hz @ 2.5 V	
C FC88-4	CAN NETWORK	15 – 1500 Hz @ 2.5 V	
I FC88-6	GROUND	GROUND	GROUND
C FC88-8	CAN NETWORK	15 – 1500 Hz @ 2.5 V	
C FC88-9	CAN NETWORK	15 – 1500 Hz @ 2.5 V	

**TRANSMISSION CONTROL MODULE: AJ27 N/A**

Pin	Description	Active	Inactive
O EM7-1	PRESSURE REGULATOR #2	GROUND (MAXIMUM PRESSURE)	B+ (NO PRESSURE)
O EM7-2	SPORT MODE SWITCH STATUS LED	GROUND = LED ON	B+
O EM7-4	PRESSURE REGULATOR #4	GROUND (MAXIMUM PRESSURE)	B+ (NO PRESSURE)
O EM7-5	PRESSURE REGULATOR #1	GROUND (MAXIMUM PRESSURE)	B+ (NO PRESSURE)
I EM7-6	GROUND	GROUND	GROUND
I EM7-8	ROTARY SWITCH 'L2' CONTACTS	B+	GROUND
I EM7-9	ROTARY SWITCH 'L4' CONTACTS	B+	GROUND
I EM7-12	SPORT MODE SWITCH STRATEGY SELECT	GROUND = SPORT	9 V = NORMAL
I EM7-13	D - 4 SWITCH	GROUND	B+
I EM7-14	TURBINE SPEED SENSOR	300 Hz @ IDLE (2.5 V)	
SG EM7-15	OUTPUT SPEED SENSOR SHIELD	GROUND	GROUND
SG EM7-16	OUTPUT SPEED SENSOR	GROUND	GROUND
SG EM7-21	FLUID TEMPERATURE SENSOR	1.31 V	
I EM7-22	FLUID TEMPERATURE SENSOR FEEDBACK	1.15 V @ 90°C	
I EM7-23	TURBINE SPEED SENSOR SHIELD	GROUND	GROUND
I EM7-26	BATTERY POWER SUPPLY	B+	B+
O EM7-28	ROTARY / D-4 / KICK DOWN SWITCHES COMMON GROUND	GROUND	GROUND
O EM7-29	PRESSURE REGULATOR #3	GROUND (MAXIMUM PRESSURE)	B+ (NO PRESSURE)
O EM7-30	SOLENOID VALVE #1	GROUND	B+
O EM7-32	SOLENOID VALVE #3	GROUND	B+
O EM7-33	SOLENOID VALVE #2	GROUND	B+
I EM7-34	GROUND	GROUND	GROUND
I EM7-36	ROTARY SWITCH 'L1' CONTACTS	B+	GROUND
I EM7-37	ROTARY SWITCH 'L3' CONTACTS	B+	GROUND
I EM7-42	TURBINE SPEED SENSOR	1.51 V @ 10 MPH (16 KMH) = 250 Hz, 20 MPH (32 KMH) = 500 Hz	
I EM7-44	OUTPUT SPEED SENSOR	1.51 V @ 10 MPH (16 KMH) = 223 Hz, 20 MPH (32 KMH) = 446 Hz	
I EM7-45	SPORT MODE SWITCH STRATEGY SELECT	10 v = SPORT	GROUND = NORMAL
O EM7-51	PRESSURE REGULATOR #5	GROUND (MAXIMUM PRESSURE)	B+ (NO PRESSURE)
O EM7-52	SOLENOID VALVES COMMON SUPPLY	B+	B+
O EM7-53	PRESSURE REGULATORS COMMON SUPPLY	B+	B+
I EM7-54	IGNITION SWITCHED POWER SUPPLY	B+	GROUND
I EM7-55	IGNITION SWITCHED POWER SUPPLY	B+	GROUND
C EM7-82	CAN NETWORK	15 – 1500 Hz	
C EM7-83	CAN NETWORK	15 – 1500 Hz	
C EM7-85	CAN NETWORK	15 – 1500 Hz	
C EM7-86	CAN NETWORK	15 – 1500 Hz	

**NOTE:** Refer to the Appendix at the rear of this book for CAN and SCP Network Messages.

**Fig. 05.1**

**COMPONENTS**

Component	Connector / Type / Color	Location / Access
D - 4 SWITCH	FC83 / 3-WAY MULTILOCK 070 / YELLOW	GEAR SELECTOR ASSEMBLY, REAR
GEAR SELECTOR ILLUMINATION MODULE	FC88 / 10-WAY MULTILOCK 070 / WHITE	FRONT OF GEAR SELECTOR ASSEMBLY
MODE SWITCH (TRANSMISSION)	FC35 / 10-WAY AMP MQL / BLACK	REARWARD OF GEAR SELECTOR
TRANSMISSION CONTROL MODULE: AJ27 N/A	EM7 / 88-WAY BOSCH / BLACK	ENGINE COMPARTMENT / CONTROL MODULE ENCLOSURE
TRANSMISSION ELECTRICAL CONNECTOR: AJ27 N/A	EM46 / 16-WAY KOSTAL / BLACK	TRANSMISSION / LEFT HAND SIDE
TRANSMISSION ROTARY SWITCH	EM47 / 10-WAY METRI-PACK 150 / BLACK	TRANSMISSION / RIGHT HAND SIDE

**HARNESS-TO-HARNESS CONNECTORS**

Connector	Type / Color	Location / Access
AC12	20-WAY MULTILOCK 070 / WHITE	FASCIA TOP CONNECTOR MOUNTING BRACKET / RIGHT HAND SIDE
EM1	20-WAY MULTILOCK 070 / WHITE	ENGINE COMPARTMENT / ADJACENT TO RIGHT HAND ENCLOSURE
EM3	14-WAY MULTILOCK 070 / GREY	ENGINE COMPARTMENT / ADJACENT TO RIGHT HAND ENCLOSURE

**GROUNDINGS**

Ground	Location / Type
EM1AL	EYELET (PAIR) – LEFT HAND LEG / ENGINE COMPARTMENT, RIGHT HAND ENCLOSURE
EM1BR	EYELET (PAIR) – RIGHT HAND LEG / ENGINE COMPARTMENT, RIGHT HAND ENCLOSURE
EM2AL	EYELET (PAIR) – LEFT HAND LEG / ENGINE COMPARTMENT, LEFT HAND ENCLOSURE
EM2BR	EYELET (PAIR) – RIGHT HAND LEG / ENGINE COMPARTMENT, LEFT HAND ENCLOSURE
FC3BR	EYELET (PAIR) – RIGHT HAND LEG / TRANSMISSION TUNNEL, LEFT HAND SIDE

**FOR CONTROL MODULE PIN OUT INFORMATION, UNFOLD PAGE TO LEFT.**

The following abbreviations are used to represent values for Control Module Pin-Out data

I	Input	D	Serial and Encoded Data	B+	Battery Voltage	kHz	Frequency x 1000
O	Output	C	CAN (Network)	V	Voltage (DC)	ms	Milliseconds
SG	Signal Ground	S	SCP Network	Hz	Frequency	mV	Millivolts

**CAUTION:** The information on this data page is furnished to aid the user in understanding circuit operation. THIS INFORMATION SHOULD BE USED FOR REFERENCE ONLY.

**NOTE:** The values listed are approximately those that can be expected at the control module connector pins with all circuit connections made and all components connected and fitted. "Active" means a load is applied or a switch is ON; "Inactive" means a load is not applied or a switch is OFF.

Refer to the front of this book for detailed information and illustrations regarding the location and identification of harnesses, relays, grounds, control modules and control module pins.

**CONTROL MODULE PIN OUT INFORMATION**

**GEAR SELECTOR ILLUMINATION MODULE**

Pin	Description	Active	Inactive
I FC88-1	IGNITION SWITCHED POWER SUPPLY	B+	GROUND
C FC88-3	CAN NETWORK	15 – 1500 Hz @ 2.5 V	
C FC88-4	CAN NETWORK	15 – 1500 Hz @ 2.5 V	
I FC88-6	GROUND	GROUND	GROUND
C FC88-8	CAN NETWORK	15 – 1500 Hz @ 2.5 V	
C FC88-9	CAN NETWORK	15 – 1500 Hz @ 2.5 V	

**TRANSMISSION CONTROL MODULE: AJ27 SC**

Pin	Description	Active	Inactive
C EM72-L	CAN NETWORK	5 – 1500 Hz	
C EM72-H	CAN NETWORK	5 – 1500 Hz	
I EM72-12	n2 SPEED SENSOR FEEDBACK	6V = 900 Hz @ 10 MPH (16 KPH); 1800 HZ @ 20 MPH (32 KH) ('2' SELECTED – '1' ENGAGED)	
O EM72-13	SPEED SENSOR COMMON VOLTAGE SUPPLY	5V	
O EM72-14	'1-2 / 4-5' SOLENOID ACTIVATE	GROUND	B+
O EM72-15	'3-4' SOLENOID ACTIVATE	GROUND	B+
O EM72-16	'2-3' SOLENOID ACTIVATE	GROUND	B+
O EM72-17	TCC SOLENOID ACTIVATE	GROUND = LOCKED	B+ = UNLOCKED
O EM72-33	SPEED SENSOR / FLUID TEMP SENSOR COMMON GROUND	GROUND	GROUND
I EM72-34	FLUID TEMP SENSOR FEEDBACK	1.75 V @ 90° C = R, D, 4, 3, 2	5 V = P, N
I EM72-35	n3 SPEED SENSOR FEEDBACK	6 V = 85 Hz @ 10 MPH (16 KPH); 170 Hz @ 20 MPH (32 KPH) ('2' SELECTED – '2' ENGAGED)	
O EM72-36	MODULATION PRESSURE REGULATOR ACTIVATE	GROUND ( 42% PWM @ IDLE)	B+
O EM72-37	SHIFT PRESSURE REGULATOR ACTIVATE	GROUND ( 39% PWM @ IDLE)	B+
O EM72-38	SOLENOID VALVE / PRESSURE REGULATOR COMMON VOLTAGE SUPPLY	B+	GROUND
I EM73-2	KICKDOWN SWITCH	GROUND (= WOT)	B+ (< WOT)
I EM73-3	SPORT MODE SWITCH	0 V = SPORT; 0 V = NORMAL	
I EM73-25	DUAL LINEAR SWITCH VOLTAGE ENCODED GEAR RECOGNITION	GROUND = R, D, 4, 3	B+ = P, N, 2
I EM73-26	DUAL LINEAR SWITCH VOLTAGE ENCODED GEAR RECOGNITION	GROUND = N, D, 4, 2	B+ = P, R, 3
I EM73-27	DUAL LINEAR SWITCH VOLTAGE ENCODED GEAR RECOGNITION	GROUND = N, 4, 3, 2 8 V = R, D	B+ = P
I EM73-28	DUAL LINEAR SWITCH VOLTAGE ENCODED GEAR RECOGNITION	GROUND = P, D, 3, 2	B+ = R, N, 4
I EM73-29	IGNITION SUPPLIED VOLTAGE	B+	GROUND
I EM73-30	TCM / DUAL LINEAR SWITCH COMMON GROUND SUPPLY	GROUND	GROUND

**NOTE:** Refer to the Appendix at the rear of this book for CAN and SCP Network Messages.

**Fig. 05.2**

**COMPONENTS**

Component	Connector / Type / Color	Location / Access
DUAL LINEAR SWITCH	FC100 / 12-WAY / MULTILOCK 070 / GREY	LEFT HAND SIDE OF GEAR SELECTOR / CENTER CONSOLE
GEAR SELECTOR ILLUMINATION MODULE	FC88 / 10-WAY MULTILOCK 070 / WHITE	FRONT OF GEAR SELECTOR ASSEMBLY
KICKDOWN SWITCH	AC27 / 1-WAY LUCAR RIGHT ANGLE / CLEAR AC28 / 1-WAY LUCAR RIGHT ANGLE / CLEAR	UNDER ACCELERATOR PEDAL
MODE SWITCH (TRANSMISSION)	FC35 / 10-WAY AMP MQL / BLACK	REARWARD OF GEAR SELECTOR
TRANSMISSION CONTROL MODULE: AJ27 SC	EM72 / 14-WAY AMP JUNIOR POWER TIMER / BLACK EM73 / 18-WAY AMP JUNIOR POWER TIMER / BLACK	ENGINE COMPARTMENT / CONTROL MODULE ENCLOSURE
TRANSMISSION ELECTRICAL CONNECTOR: AJ27 SC	GB1 / 13-WAY KOSTAL 1.5 / BLACK	TRANSMISSION

**HARNESS-TO-HARNESS CONNECTORS**

Connector	Type / Color	Location / Access
AC12	20-WAY MULTILOCK 070 / WHITE	FASCIA TOP CONNECTOR MOUNTING BRACKET / RIGHT HAND SIDE
EM1	20-WAY MULTILOCK 070 / WHITE	ENGINE COMPARTMENT / ADJACENT TO RIGHT HAND ENCLOSURE
EM2	20-WAY MULTILOCK 070 / YELLOW	ENGINE COMPARTMENT / ADJACENT TO RIGHT HAND ENCLOSURE
EM3	14-WAY MULTILOCK 070 / GREY	ENGINE COMPARTMENT / ADJACENT TO RIGHT HAND ENCLOSURE
GB2	12-WAY AUGAT 1.6 / BLACK	ENGINE COMPARTMENT / BRACKET ON TOP OF TRANSMISSION

**GROUNDS**

Ground	Location / Type
EM1AL	EYELET (PAIR) – LEFT HAND LEG / ENGINE COMPARTMENT, RIGHT HAND ENCLOSURE
EM2AL	EYELET (PAIR) – LEFT HAND LEG / ENGINE COMPARTMENT, LEFT HAND ENCLOSURE
FC3BL	EYELET (PAIR) – LEFT HAND LEG / TRANSMISSION TUNNEL, LEFT HAND SIDE
FC3BR	EYELET (PAIR) – RIGHT HAND LEG / TRANSMISSION TUNNEL, LEFT HAND SIDE

**FOR CONTROL MODULE PIN OUT INFORMATION, UNFOLD PAGE TO LEFT.**

The following abbreviations are used to represent values for Control Module Pin-Out data

I	Input	D	Serial and Encoded Data	B+	Battery Voltage	kHz	Frequency x 1000
O	Output	C	CAN (Network)	V	Voltage (DC)	ms	Milliseconds
SG	Signal Ground	S	SCP Network	Hz	Frequency	mV	Millivolts

**CAUTION:** The information on this data page is furnished to aid the user in understanding circuit operation. THIS INFORMATION SHOULD BE USED FOR REFERENCE ONLY.

**NOTE:** The values listed are approximately those that can be expected at the control module connector pins with all circuit connections made and all components connected and fitted. "Active" means a load is applied or a switch is ON; "Inactive" means a load is not applied or a switch is OFF.

Refer to the front of this book for detailed information and illustrations regarding the location and identification of harnesses, relays, grounds, control modules and control module pins.



**CONTROL MODULE PIN OUT INFORMATION**

**Fig. 05.3**

**BODY PROCESSOR MODULE**

Pin	Description	Active	Inactive
I FC14-15	IGNITION SWITCHED GROUND SUPPLY	GROUND	GROUND
I FC14-32	IGNITION SWITCHED GROUND SUPPLY	GROUND	GROUND (GEARSHIFT LOCKED)
O FC14-48	GEARSHIFT INTERLOCK SOLENOID SUPPLY	B+ (GEARSHIFT FREE)	GROUND (KEY RELEASED)
O FC14-51	KEY LOCK SOLENOID SUPPLY	B+ (KEY CAPTIVE)	B+ (PARK)
I FC14-58	NOT-IN-PARK	GROUND (R,N,D,4,3,2)	B+
I FC14-80	BATTERY POWER SUPPLY (LOGIC)	B+	B+
S FC14-84	SCP NETWORK	2 – 1600 Hz	
S FC14-85	SCP NETWORK	2 – 1600 Hz	
I FC14-104	LIGHTING / MOTORS BATTERY POWER SUPPLY	B+	

**ENGINE CONTROL MODULE**

Pin	Description	Active	Inactive
I EM82-08	BRAKE SWITCH	GROUND	B+
C EM83-16	CAN NETWORK	15 – 1500 Hz	
C EM83-25	CAN NETWORK	15 – 1500 Hz	

**GEAR SELECTOR ILLUMINATION MODULE**

Pin	Description	Active	Inactive
C FC88-4	CAN NETWORK	15 – 1500 Hz @ 2.5 V	
C FC88-3	CAN NETWORK	15 – 1500 Hz @ 2.5 V	
C FC88-8	CAN NETWORK	15 – 1500 Hz @ 2.5 V	
C FC88-9	CAN NETWORK	15 – 1500 Hz @ 2.5 V	

**MAJOR INSTRUMENT PACK**

Pin	Description	Active	Inactive
C FC25-11	CAN NETWORK	15 – 1500 Hz	
S FC25-13	SCP NETWORK	2 – 1600 Hz	
S FC25-14	SCP NETWORK	2 – 1600 Hz	
C FC25-23	CAN NETWORK	15 – 1500 Hz	

**NOTE:** Refer to the Appendix at the rear of this book for CAN and SCP Network Messages.

**COMPONENTS**

Component	Connector / Type / Color	Location / Access
BODY PROCESSOR MODULE	FC14 / 104-WAY AMP EEEEC / GREY	PASSENGER SIDE FASCIA / AIRBAG BRACKET
BRAKE SWITCH	AC24 / 4-WAY MULTILOCK 070 / WHITE	TOP OF BRAKE PEDAL
ENGINE CONTROL MODULE	EM80 / 31-WAY AMP 403 / NATURAL EM81 / 24-WAY AMP 403 / NATURAL EM82 / 17-WAY AMP 403 / NATURAL EM83 / 28-WAY AMP 403 / NATURAL EM84 / 22-WAY AMP 403 / NATURAL EM85 / 12-WAY MULTILOCK 070 / WHITE	ENGINE COMPARTMENT / CONTROL MODULE ENCLOSURE
GEAR SELECTOR ILLUMINATION MODULE	FC88 / 10-WAY MULTILOCK 070 / WHITE	FRONT OF GEAR SELECTOR ASSEMBLY
GEARSHIFT INTERLOCK SOLENOID	FC86 / 2-WAY MULTILOCK 070 / WHITE	GEAR SELECTOR ASSEMBLY
KEYLOCK SOLENOID (COLUMN SWITCHGEAR)	SC1 / 12-WAY MULTILOCK 070 / WHITE	STEERING COLUMN
MAJOR INSTRUMENT PACK	FC25 / 26-WAY AMP MICRO QUAD LOCK / BLACK FC26 / 26-WAY AMP MICRO QUAD LOCK / YELLOW	FASCIA
NOT-IN-PARK MICROSWITCH	FC87 / 3-WAY MULTILOCK 070 / WHITE	GEAR SELECTOR ASSEMBLY

**HARNESS-TO-HARNESS CONNECTORS**

Connector	Type / Color	Location / Access
AC13	20-WAY MULTILOCK 070 / YELLOW	FASCIA BOTTOM CONNECTOR MOUNTING BRACKET / RIGHT HAND SIDE
EM1	20-WAY MULTILOCK 070 / WHITE	ENGINE COMPARTMENT / ADJACENT TO RIGHT HAND ENCLOSURE

**GROUNDS**

Ground	Location / Type
FC2BR	EYELET (PAIR) – RIGHT HAND LEG / RIGHT HAND 'A' POST
FC3BR	EYELET (PAIR) – RIGHT HAND LEG / TRANSMISSION TUNNEL, LEFT HAND SIDE
FC4BR	EYELET (PAIR) – RIGHT HAND LEG / LEFT HAND 'A' POST

**FOR CONTROL MODULE PIN OUT INFORMATION, UNFOLD PAGE TO LEFT.**

The following abbreviations are used to represent values for Control Module Pin-Out data

I	Input	D	Serial and Encoded Data	B+	Battery Voltage	kHz	Frequency x 1000
O	Output	C	CAN (Network)	V	Voltage (DC)	ms	Milliseconds
SG	Signal Ground	S	SCP Network	Hz	Frequency	mV	Millivolts

**CAUTION:** The information on this data page is furnished to aid the user in understanding circuit operation. THIS INFORMATION SHOULD BE USED FOR REFERENCE ONLY.

**NOTE:** The values listed are approximately those that can be expected at the control module connector pins with all circuit connections made and all components connected and fitted. "Active" means a load is applied or a switch is ON; "Inactive" means a load is not applied or a switch is OFF.

Refer to the front of this book for detailed information and illustrations regarding the location and identification of harnesses, relays, grounds, control modules and control module pins.

**CONTROL MODULE PIN OUT INFORMATION**

**Fig. 06.1**

**ABS / TRACTION CONTROL CONTROL MODULE**

	Pin	Description	Active	Inactive
O	LF37-1	BRAKE FLUID RESERVOIR LEVEL SWITCH REFERENCE	B+	B+
I	LF37-2	BRAKE SWITCH	GROUND	B+
I	LF37-3	RH FRONT WHEEL SPEED SENSOR	2.5 V @ 10 MPH (16 KMH) = 100 Hz; 20 MPH (32 KMH) = 200 Hz	
SG	LF37-4	RH FRONT WHEEL SPEED SENSOR	2.5 V @ REST	
C	LF37-5	CAN NETWORK	15 - 1500 Hz	
SG	LF37-6	RH REAR WHEEL SPEED SENSOR	2.5 V @ REST	
I	LF37-7	RH REAR WHEEL SPEED SENSOR	2.5 V @ 10 MPH (16 KMH) = 100 Hz; 20 MPH (32 KMH) = 200 Hz	
I	LF37-8	GROUND	GROUND	GROUND
I	LF37-9	BATTERY POWER SUPPLY	B+	B+
	LF37-10	NOT USED		
	LF37-11	NOT USED		
I	LF37-13	BRAKE FLUID RESERVOIR LEVEL SWITCH	GROUND	B+
I	LF37-14	STABILITY / TRACTION CONTROL SWITCH	GROUND (MOMENTARY)	B+
C	LF37-15	CAN NETWORK	15 - 1500 Hz	
O	LF37-16	STABILITY / TRACTION CONTROL SWITCH STATE LED	GROUND	B+
I	LF37-17	LH FRONT WHEEL SPEED SENSOR	2.5 V @ 10 MPH (16 KMH) = 100 Hz; 20 MPH (32 KMH) = 200 Hz	
SG	LF37-18	LH FRONT WHEEL SPEED SENSOR	2.5 V @ REST	
	LF37-19	NOT USED		
I	LF37-20	IGNITION SWITCHED SUPPLY	B+	GROUND
I	LF37-21	LH REAR WHEEL SPEED SENSOR	2.5 V @ 10 MPH (16 KMH) = 100 Hz; 20 MPH (32 KMH) = 200 Hz	
SG	LF37-22	LH REAR WHEEL SPEED SENSOR	2.5 V @ REST	
I	LF37-24	GROUND	GROUND	GROUND
I	LF37-25	BATTERY POWER SUPPLY	B+	B+

**NOTE:** Refer to the Appendix at the rear of this book for CAN and SCP Network Messages.

**COMPONENTS**

Component	Connector / Type / Color	Location / Access
ABS / TRACTION CONTROL CONTROL MODULE	LF37 / 25-WAY AMP HYBRID / BLACK	ENGINE COMPARTMENT / FRONT LEFT
BRAKE FLUID RESERVOIR	EM37 / 2-WAY AMP JUNIOR POWER TIMER / BLACK	ENGINE COMPARTMENT / BRAKE BOOSTER ENCLOSURE
BRAKE SWITCH	AC24 / 4-WAY MULTILOCK 070 / WHITE	TOP OF BRAKE PEDAL
STABILITY / TRACTION CONTROL SWITCH (CENTER CONSOLE SWITCH PACK)	FC55 / 20-WAY FORD IDC / BLACK	CENTER CONSOLE SWITCH PACK
WHEEL SPEED SENSOR - LH FRONT	FL1 / 2-WAY REINSHAGEN METRI 630 / BLACK	WHEEL HUB
WHEEL SPEED SENSOR - LH REAR	RL1 / 2-WAY REINSHAGEN METRI 630 / BLACK	WHEEL HUB
WHEEL SPEED SENSOR - RH FRONT	FR1 / 2-WAY REINSHAGEN METRI 630 / BLACK	WHEEL HUB
WHEEL SPEED SENSOR - RH REAR	RR1 / 2-WAY REINSHAGEN METRI 630 / BLACK	WHEEL HUB

**HARNESS-TO-HARNESS CONNECTORS**

Connector	Type / Color	Location / Access
AC13	20-WAY MULTILOCK 070 / YELLOW	FASCIA BOTTOM CONNECTOR MOUNTING BRACKET / RIGHT HAND SIDE
BT2	20-WAY MULTILOCK 070 / WHITE	TRUNK / ABOVE RIGHT HAND REAR WHEEL ARCH
BT72	4-WAY ECONOSEAL III LC / BLACK	REAR OF REAR HUB ASSEMBLY / LEFT HAND SIDE
BT73	4-WAY ECONOSEAL III LC / BLACK	REAR OF REAR HUB ASSEMBLY / RIGHT HAND SIDE
LF40	13-WAY ECONOSEAL III LC / BLACK	ENGINE COMPARTMENT / LEFT HAND ENCLOSURE
LF41	2-WAY ECONOSEAL III LC / BLACK	ENGINE COMPARTMENT / ADJACENT TO ENGINE COMPARTMENT FUSE BOX
LF42	2-WAY ECONOSEAL III LC / BLACK	ENGINE COMPARTMENT / ADJACENT TO AIR CLEANER
LF60	20-WAY MULTILOCK 070 / WHITE	LEFT HAND 'A' POST CONNECTOR MOUNTING BRACKET / 'A' POST TRIM
RH1	20-WAY MULTILOCK 070 / GREY	BEHIND GLOVE BOX

**GROUND**

Ground	Location / Type
FC2BR	EYELET (PAIR) - RIGHT HAND LEG / RIGHT HAND 'A' POST
FC4BR	EYELET (PAIR) - RIGHT HAND LEG / LEFT HAND 'A' POST
LF3AS	EYELET (SINGLE) / ENGINE COMPARTMENT, FORWARD OF LEFT HAND HOOD CATCH

**FOR CONTROL MODULE PIN OUT INFORMATION, UNFOLD PAGE TO LEFT.**

The following abbreviations are used to represent values for Control Module Pin-Out data

I	Input	D	Serial and Encoded Data	B+	Battery Voltage	kHz	Frequency x 1000
O	Output	C	CAN (Network)	V	Voltage (DC)	ms	Milliseconds
SG	Signal Ground	S	SCP Network	Hz	Frequency	mV	Millivolts

**CAUTION:** The information on this data page is furnished to aid the user in understanding circuit operation. THIS INFORMATION SHOULD BE USED FOR REFERENCE ONLY.

**NOTE:** The values listed are approximately those that can be expected at the control module connector pins with all circuit connections made and all components connected and fitted. "Active" means a load is applied or a switch is ON; "Inactive" means a load is not applied or a switch is OFF.

Refer to the front of this book for detailed information and illustrations regarding the location and identification of harnesses, relays, grounds, control modules and control module pins.

CONTROL MODULE PIN OUT INFORMATION

**Fig. 06.2**

POWER ASSISTED STEERING CONTROL MODULE

	Pin	Description	Active	Inactive
O	FC16-2	TRANSDUCER NEGATIVE	2 V @ IDLE DECREASING WITH VEHICLE SPEED	
I	FC16-4	VEHICLE SPEED	B+ @ 10 MPH (16 KMH) = 20 Hz, 20 MPH (32 KMH) = 40 Hz	
O	FC16-5	TRANSDUCER POSITIVE	9 V @ IDLE INCREASING WITH VEHICLE SPEED	
I	FC16-6	IGNITION SWITCHED POWER SUPPLY	B+	0 V
I	FC16-8	GROUND	0 V	0 V

COMPONENTS

Component	Connector / Type / Color	Location / Access
POWER ASSISTED STEERING CONTROL MODULE	FC16 / 9-WAY RISTS RELAY / BLACK AND RED	FASCIA / ADJACENT TO RH SIDE FUSE BOX
VARIABLE STEERING CONVERTER - LHD	LL2 / 2-WAY AMP JUNIOR POWER TIMER / BLACK	STEERING RACK / CONTROL VALVE
VARIABLE STEERING CONVERTER - RHD	EM18 / 2-WAY AMP JUNIOR POWER TIMER / NATURAL	STEERING RACK / CONTROL VALVE

HARNESSTO-HARNESSTO CONNECTORS

Connector	Type / Color	Location / Access
EM2	20-WAY MULTILOCK 070 / YELLOW	ENGINE COMPARTMENT / ADJACENT TO RIGHT HAND ENCLOSURE
LL1	2-WAY ECONOSEAL III LC / BLACK	ENGINE COMPARTMENT / ADJACENT TO STARTER MOTOR

GROUNDS

Ground	Location / Type
FC2BR	EYELET (PAIR) - RIGHT HAND LEG / RIGHT HAND 'A' POST
FC4BR	EYELET (PAIR) - RIGHT HAND LEG / LEFT HAND 'A' POST

FOR CONTROL MODULE PIN OUT INFORMATION, UNFOLD PAGE TO LEFT.

The following abbreviations are used to represent values for Control Module Pin-Out data

I	Input	D	Serial and Encoded Data	B+	Battery Voltage	kHz	Frequency x 1000
O	Output	C	CAN (Network)	V	Voltage (DC)	ms	Milliseconds
SG	Signal Ground	S	SCP Network	Hz	Frequency	mV	Millivolts

CAUTION: The information on this data page is furnished to aid the user in understanding circuit operation. THIS INFORMATION SHOULD BE USED FOR REFERENCE ONLY.

NOTE: The values listed are approximately those that can be expected at the control module connector pins with all circuit connections made and all components connected and fitted. "Active" means a load is applied or a switch is ON; "Inactive" means a load is not applied or a switch is OFF.

Refer to the front of this book for detailed information and illustrations regarding the location and identification of harnesses, relays, grounds, control modules and control module pins.

**CONTROL MODULE PIN OUT INFORMATION**

**Fig. 06.3**

**ADAPTIVE DAMPING CONTROL MODULE**

Pin	Description	Active	Inactive
O BT69-1	MAJOR INSTRUMENT PACK ADAPTIVE DAMPING MIL	GROUND	B+
O BT69-3	ACCELEROMETER COMMON GROUND SUPPLY	GROUND	GROUND
D BT69-10	SERIAL COMMUNICATIONS		
I BT69-11	IGNITION SWITCHED POWER SUPPLY	B+	GROUND
O BT69-13	LH REAR DAMPER BATTERY POWER SUPPLY	B+	B+
O BT69-14	RH FRONT DAMPER BATTERY POWER SUPPLY	B+	B+
O BT69-15	RH REAR DAMPER BATTERY POWER SUPPLY	B+	B+
I BT69-18	GROUND	GROUND	GROUND
I BT69-20	FRONT LATERAL ACCELEROMETER FEEDBACK	< 0.2 V OR > 4.8 V	2.3 - 2.7 V = HARD
I BT69-21	FRONT VERTICAL ACCELEROMETER FEEDBACK	< 0.2 V OR > 4.8 V	2.3 - 2.7 V = HARD
I BT69-22	REAR VERTICAL ACCELEROMETER FEEDBACK	< 0.2 V OR > 4.8 V	2.3 - 2.7 V = HARD
I BT69-24	VEHICLE SPEED SIGNAL	22 Hz @ 10 MPH (16 KMH); 44 Hz @ 20 MPH (32 KMH) @ B+	
O BT69-25	ACCELEROMETER COMMON VOLTAGE SUPPLY	5 V	5 V
I BT69-26	BRAKE SWITCH	GROUND	B+
I BT69-27	BATTERY POWER SUPPLY	B+	B+
D BT69-28	SERIAL COMMUNICATIONS		
O BT69-30	LH FRONT DAMPER BATTERY POWER SUPPLY	B+	B+
O BT69-31	LH FRONT DAMPER	GROUND	B+
O BT69-32	LH REAR DAMPER	GROUND	B+
O BT69-33	RH FRONT DAMPER	GROUND	B+
O BT69-34	RH REAR DAMPER	GROUND	B+

**COMPONENTS**

Component	Connector / Type / Color	Location / Access
ACCELEROMETER - FRONT LATERAL	EM59 / 3-WAY AMP MQL / BLACK	ENGINE COMPARTMENT / ADJACENT TO ECM
ACCELEROMETER - REAR VERTICAL	BT52 / 3-WAY AMP MQL / BLACK	TRUNK / BELOW FUEL TANK
ACCELEROMETER - FRONT VERTICAL	FC7 / 3-WAY AMP MQL / BLACK	CENTER CONSOLE / BEHIND ICE HEAD UNIT
ADAPTIVE DAMPING CONTROL MODULE	BT69 / 35-WAY AMP / BLACK	TRUNK / ADJACENT TO ELECTRICAL CARRIER
BRAKE SWITCH	AC24 / 4-WAY MULTILOCK 070 / WHITE	TOP OF BRAKE PEDAL
DAMPER SOLENOID - LH FRONT	LF43 / 2-WAY DELPHI/REINSHAGEN / BLACK	TOP OF LEFT HAND FRONT DAMPER
DAMPER SOLENOID - LH REAR	DL2 / 2-WAY DELPHI/REINSHAGEN / BLACK	TOP OF LEFT HAND REAR DAMPER
DAMPER SOLENOID - RH FRONT	LF44 / 2-WAY DELPHI/REINSHAGEN / BLACK	TOP OF RIGHT HAND FRONT DAMPER
DAMPER SOLENOID - RH REAR	DR2 / 2-WAY DELPHI/REINSHAGEN / BLACK	TOP OF RIGHT HAND REAR DAMPER

**HARNESS-TO-HARNESS CONNECTORS**

Connector	Type / Color	Location / Access
AC13	20-WAY MULTILOCK 070 / YELLOW	FASCIA BOTTOM CONNECTOR MOUNTING BRACKET / RIGHT HAND SIDE
BT1	20-WAY MULTILOCK 070 / WHITE	TRUNK / ABOVE RIGHT HAND REAR WHEEL ARCH
BT3	18-WAY MULTILOCK 070 / YELLOW	TRUNK / ABOVE RIGHT HAND REAR WHEEL ARCH
BT72	4-WAY ECONOSEAL III LC / BLACK	TRUNK / BELOW FUEL TANK
BT73	4-WAY ECONOSEAL III LC / BLACK	TRUNK / BELOW FUEL TANK
EM3	14-WAY MULTILOCK 070 / GREY	ENGINE COMPARTMENT / ADJACENT TO RIGHT HAND ENCLOSURE
LF1	20-WAY MULTILOCK 070 / GREY	LEFT HAND 'A' POST CONNECTOR MOUNTING BRACKET / 'A' POST TRIM
LF60	20-WAY MULTILOCK 070 / WHITE	LEFT HAND 'A' POST CONNECTOR MOUNTING BRACKET / 'A' POST TRIM
RH1	20-WAY MULTILOCK 070 / GREY	BEHIND GLOVE BOX
RH12	18-WAY MULTILOCK 070 / YELLOW	REAR OF CENTER CONSOLE ASSEMBLY
RL3	2-WAY AUGAT 1.6 / BLACK	REAR OF REAR HUB ASSEMBLY / LEFT HAND SIDE
RR3	2-WAY AUGAT 1.6 / BLACK	REAR OF REAR HUB ASSEMBLY / RIGHT HAND SIDE

**GROUND**

Ground	Location / Type
BT2BL	EYELET (PAIR) - LEFT HAND LEG / TRUNK, RIGHT REAR

FOR CONTROL MODULE PIN OUT INFORMATION, UNFOLD PAGE TO LEFT.

The following abbreviations are used to represent values for Control Module Pin-Out data

I	Input	D	Serial and Encoded Data	B+	Battery Voltage	kHz	Frequency x 1000
O	Output	C	CAN (Network)	V	Voltage (DC)	ms	Milliseconds
SG	Signal Ground	S	SCP Network	Hz	Frequency	mV	Millivolts

**CAUTION:** The information on this data page is furnished to aid the user in understanding circuit operation. THIS INFORMATION SHOULD BE USED FOR REFERENCE ONLY.

**NOTE:** The values listed are approximately those that can be expected at the control module connector pins with all circuit connections made and all components connected and fitted. "Active" means a load is applied or a switch is ON; "Inactive" means a load is not applied or a switch is OFF.

Refer to the front of this book for detailed information and illustrations regarding the location and identification of harnesses, relays, grounds, control modules and control module pins.

**CONTROL MODULE PIN OUT INFORMATION**

**Fig. 06.4**

**ADAPTIVE SPEED CONTROL BOOSTER CONTROL MODULE**

Pin	Description	Active	Inactive
O AL4-01	AIR CONTROL VALVE SOLENOID DRIVE	PWM (-VE)	
O AL4-02	RELEASE SWITCH REFERENCE VOLTAGE	5 V	5 V
O AL4-04	BRAKE BOOSTER PRESSURE SENSOR 2 REFERENCE VOLTAGE	5 V	5 V
SG AL4-05	BRAKE BOOSTER PRESSURE SENSOR 2 SIGNAL GROUND	GROUND	GROUND
SG AL4-07	BRAKE BOOSTER PRESSURE SENSOR 1 SIGNAL GROUND	GROUND	GROUND
O AL4-08	BRAKE BOOSTER PRESSURE SENSOR 1 REFERENCE VOLTAGE	5 V	5 V
O AL4-09	AIR CONTROL VALVE SOLENOID POWER SUPPLY	5 V	5 V
I AL4-10	RELEASE SWITCH NORMALLY OPEN	GROUND	5 V
I AL4-11	RELEASE SWITCH NORMALLY CLOSED	5 V	GROUND
I AL4-13	BRAKE BOOSTER PRESSURE SENSOR 2 FEEDBACK	0 – 5 V	
I AL4-16	BRAKE BOOSTER PRESSURE SENSOR 1 FEEDBACK	0 – 5 V	
I EM87-02	IGNITION SWITCHED SUPPLY	B+	B+
C EM87-03	CAN NETWORK	15 – 1500 Hz	
I EM87-06	BATTERY POWER SUPPLY	B+	B+
C EM87-07	CAN NETWORK	15 – 1500 Hz	
I EM87-10	POWER GROUND	GROUND	GROUND

**ADAPTIVE SPEED CONTROL CONTROL MODULE**

Pin	Description	Active	Inactive
I LF61-01	POWER GROUND	GROUND	GROUND
I LF61-02	BATTERY POWER SUPPLY	B+	B+
I LF61-03	IGNITION SWITCHED POWER SUPPLY	B+	B+
C LF61-11	CAN NETWORK	15 – 1500 Hz	
C LF61-12	CAN NETWORK	15 – 1500 Hz	
C LF61-13	CAN NETWORK	15 – 1500 Hz	
C LF61-14	CAN NETWORK	15 – 1500 Hz	

**NOTE:** Refer to the Appendix at the rear of this book for CAN and SCP Network Messages.

**COMPONENTS**

Component	Connector / Type / Color	Location / Access
ADAPTIVE SPEED CONTROL BOOSTER CONTROL MODULE	AL4 / 16-WAY / BLACK EM87 / 10-WAY AMP JUNIOR POWER TIMER / BLACK	ENGINE COMPARTMENT / CONTROL MODULE ENCLOSURE
ADAPTIVE SPEED CONTROL BRAKE BOOSTER	AL1 / 6-WAY / BLACK	ADJACENT TO BRAKE FLUID RESERVOIR
ADAPTIVE SPEED CONTROL CONTROL MODULE	LF61 / 24-WAY DELPHI MICROPACK 100W SERIES / BLACK	ENGINE COMPARTMENT / FORWARD OF RADIATOR
ADAPTIVE SPEED CONTROL MASTER SWITCH	FC63 / 10-WAY AMP MQL / NATURAL	REARWARD OF GEAR SELECTOR
BRAKE BOOSTER PRESSURE SENSOR 1	AL2 / 3-WAY / BLACK	ADJACENT TO BRAKE FLUID RESERVOIR
BRAKE BOOSTER PRESSURE SENSOR 2	AL3 / 3-WAY / BLACK	ADJACENT TO BRAKE FLUID RESERVOIR
BRAKE CANCEL SWITCH	AC24 / 4-WAY MULTILOCK 070 / WHITE	TOP OF BRAKE PEDAL
ENGINE CONTROL MODULE	EM80 / 31-WAY AMP 403 / NATURAL EM81 / 24-WAY AMP 403 / NATURAL EM82 / 17-WAY AMP 403 / NATURAL EM83 / 28-WAY AMP 403 / NATURAL EM84 / 22-WAY AMP 403 / NATURAL EM85 / 12-WAY MULTILOCK 070 / WHITE	ENGINE COMPARTMENT / CONTROL MODULE ENCLOSURE
SPEED CONTROL SWITCHES (STEERING WHEEL)	SW3 / 3-WAY EPC / BLACK	CENTER OF STEERING WHEEL

**HARNESS-TO-HARNESS CONNECTORS**

Connector	Type / Color	Location / Access
AC13	20-WAY MULTILOCK 070 / YELLOW	FASCIA BOTTOM CONNECTOR MOUNTING BRACKET / RIGHT HAND SIDE
EM3	14-WAY MULTILOCK 070 / GREY	ENGINE COMPARTMENT / ADJACENT TO RIGHT HAND ENCLOSURE
LF40	13-WAY ECONOSEAL III LC / BLACK	ENGINE COMPARTMENT / LEFT HAND ENCLOSURE
SC3	12-WAY MULTILOCK 070 / GREY	RIGHT HAND SIDE OF STEERING COLUMN

**GROUNDS**

Ground	Location / Type
EM1BR	EYELET (PAIR) – RIGHT HAND LEG / ENGINE COMPARTMENT, RIGHT HAND ENCLOSURE
EM2BR	EYELET (PAIR) – RIGHT HAND LEG / ENGINE COMPARTMENT, LEFT HAND ENCLOSURE
FC3BL	EYELET (PAIR) – LEFT HAND LEG / TRANSMISSION TUNNEL, LEFT HAND SIDE
LF1BS	EYELET (SINGLE) / RIGHT HAND HEADLAMP

**FOR CONTROL MODULE PIN OUT INFORMATION, UNFOLD PAGE TO LEFT.**

The following abbreviations are used to represent values for Control Module Pin-Out data

I	Input	D	Serial and Encoded Data	B+	Battery Voltage	kHz	Frequency x 1000
O	Output	C	CAN (Network)	V	Voltage (DC)	ms	Milliseconds
SG	Signal Ground	S	SCP Network	Hz	Frequency	mV	Millivolts

**CAUTION:** The information on this data page is furnished to aid the user in understanding circuit operation. THIS INFORMATION SHOULD BE USED FOR REFERENCE ONLY.

**NOTE:** The values listed are approximately those that can be expected at the control module connector pins with all circuit connections made and all components connected and fitted. "Active" means a load is applied or a switch is ON; "Inactive" means a load is not applied or a switch is OFF.

Refer to the front of this book for detailed information and illustrations regarding the location and identification of harnesses, relays, grounds, control modules and control module pins.

CONTROL MODULE PIN OUT INFORMATION

**Fig. 07.1**

**AIR CONDITIONING CONTROL MODULE**

Pin	Description	Active	Inactive
O	AC1-6	DEFROST VENT SERVO MOTOR	B+
O	AC1-7	CENTER VENT SERVO MOTOR	B+
O	AC1-8	LH FRESH / RECIRCULATION VENT MOTOR	B+
O	AC1-9	RH FRESH / RECIRCULATION VENT MOTOR	B+
O	AC1-12	FOOTWELL VENT SERVO MOTOR	B+
O	AC1-13	COOL AIR BYPASS VENT SERVO MOTOR	B+
O	AC1-19	DEFROST VENT SERVO MOTOR	B+
O	AC1-20	CENTER VENT SERVO MOTOR	B+
O	AC1-21	LH FRESH / RECIRCULATION VENT SERVO MOTOR	B+
O	AC1-22	RH FRESH / RECIRCULATION VENT SERVO MOTOR	B+
O	AC1-25	FOOTWELL SERVO MOTOR	B+
O	AC1-26	COOL AIR BYPASS SERVO MOTOR	B+
I	AC2-1	SOLAR SENSOR FEEDBACK	0.75 V - 4.75 V, INCREASING WITH SOLAR LOAD
I	AC2-2	CENTER VENT POTENTIOMETER FEEDBACK	> 3.5 V = OPEN
I	AC2-3	RH FRESH / RECIRCULATION VENT POTENTIOMETER FEEDBACK	> 3.5 V = OPEN
I	AC2-5	COOL AIR BYPASS VENT POTENTIOMETER FEEDBACK	> 3.5 V = OPEN
I	AC2-6	ENGINE COOLANT TEMPERATURE	2.5 V @ 90° C; DECREASING WITH TEMPERATURE
I	AC2-10	DEFROST VENT POTENTIOMETER FEEDBACK	> 3.5 V = OPEN
I	AC2-11	LH FRESH / RECIRCULATION VENT POTENTIOMETER FEEDBACK	> 3.5 V = OPEN
I	AC2-13	FOOTWELL VENT POTENTIOMETER FEEDBACK	> 3.5 V = OPEN
O	AC3-2	CLOCK	B+ (1.45 Hz)
D	AC3-3	SERIAL DATA OUTPUT TO CONTROL PANEL	
I	AC3-5	AMBIENT TEMPERATURE SENSOR FEEDBACK	2.18 V @ 25° C; DECREASING WITH TEMPERATURE
I	AC3-6	HEATER MATRIX TEMPERATURE SENSOR FEEDBACK	2.25 V @ 20° C; DECREASING WITH TEMPERATURE
D	AC3-7	SERIAL DATA INPUT FROM CONTROL PANEL	
O	AC3-8	START	B+ (MOMENTARY)
I	AC3-11	IN CAR TEMPERATURE SENSOR FEEDBACK	3.25 V @ 0° C; DECREASING WITH TEMPERATURE
I	AC3-12	EVAPORATOR TEMPERATURE SENSOR FEEDBACK	3.25 V @ 0° C; DECREASING WITH TEMPERATURE
I	AC4-1	IGNITION SWITCHED POWER SUPPLY	B+
I	AC4-2	ISOLATE RELAY CONTROLLED BATTERY POWER SUPPLY	B+
I	AC4-3	IGNITION SWITCHED GROUND	0V
O	AC4-4	CONTROL PANEL BATTERY POWER SUPPLY	B+
I	AC4-5	BATTERY POWER SUPPLY	B+
I	AC4-6	ENGINE SPEED SIGNAL	5 V @ 1000 RPM = 45 Hz; 2000 RPM = 90 Hz
O	AC4-8	POTENTIOMETER COMMON REFERENCE VOLTAGE	5 V
D	AC4-10	SERIAL COMMUNICATIONS INPUT	
O	AC4-12	CONTROL PANEL BATTERY POWER SUPPLY	B+
I	AC4-13	GROUND	0V
O	AC4-14	CONTROL PANEL GROUND SUPPLY	0V
O	AC4-15	ISOLATE RELAY ACTIVE	B+
I	AC4-16	VEHICLE SPEED SIGNAL	22 Hz @ 10 MPH (16 KM/H); 44 Hz @ 20 MPH (32 KM/H) @ B+
O	AC4-18	ASPIRATOR MOTOR POWER SUPPLY	B+
O	AC4-19	POTENTIOMETER COMMON REFERENCE GROUND	0V
I	AC4-20	GROUND	0V
D	AC4-21	SERIAL COMMUNICATIONS OUTPUT	

**COMPONENTS**

Component	Connector / Type / Color	Location / Access
AIR CONDITIONING CONTROL MODULE	AC1 / 26-WAY MULTILOCK 47 / GREY AC2 / 16-WAY MULTILOCK 47 / GREY AC3 / 12-WAY MULTILOCK 47 / GREY AC4 / 22-WAY MULTILOCK 47 / GREY	A/C UNIT / RIGHT HAND SIDE
AIR CONDITIONING CONTROL PANEL	FC43 / 12-WAY MULTILOCK 040 / BLUE	CENTER CONSOLE
AIR INTAKE - LH BLOWER	AC5 / 15-WAY SUMITOMO 090 HYBRID / GREEN	A/C UNIT / LEFT HAND SIDE
AIR INTAKE - RH BLOWER	AC6 / 15-WAY SUMITOMO 090 HYBRID / GREEN	A/C UNIT / RIGHT HAND SIDE
AMBIENT TEMPERATURE SENSOR	LF29 / 2-WAY YAZAKI 0902 / BLACK	ADJACENT TO RIGHT HAND HORN
ASPIRATOR ASSEMBLY	FC12 / 4-WAY MULTILOCK 070 / WHITE	DRIVER KNEE BOLSTER
EVAPORATOR / HEATER MATRIX ASSEMBLY	AC7 / 12-WAY MULTILOCK 040 / BLACK	A/C UNIT / LEFT HAND SIDE
SOLAR SENSOR	FC52 / 2-WAY MULTILOCK 070 / GREY	DRIVER SIDE FASCIA / ADJACENT TO DEFROST VENT
VENT ASSEMBLY	FC44 / 12-WAY MULTILOCK 040 / BLACK	A/C UNIT / TOP

**RELAYS**

Relay	Color / Stripe	Connector / Color	Location / Access
AIR CONDITIONING ISOLATE RELAY	BLACK	FC24 / BLACK	RH FASCIA RELAYS

**HARNESS-TO-HARNESS CONNECTORS**

Connector	Type / Color	Location / Access
AC12	20-WAY MULTILOCK 070 / WHITE	FASCIA TOP CONNECTOR MOUNTING BRACKET / RIGHT HAND SIDE
AC13	20-WAY MULTILOCK 070 / YELLOW	FASCIA BOTTOM CONNECTOR MOUNTING BRACKET / RIGHT HAND SIDE
AC15	20-WAY MULTILOCK 070 / GREY	FASCIA BOTTOM CONNECTOR MOUNTING BRACKET / RIGHT HAND SIDE
AC15	20-WAY MULTILOCK 070 / GREY	FASCIA BOTTOM CONNECTOR MOUNTING BRACKET / RIGHT HAND SIDE
LF60	20-WAY MULTILOCK 070 / WHITE	LEFT HAND 'A' POST CONNECTOR MOUNTING BRACKET / 'A' POST TRIM

**GROUND**

Ground	Location / Type
FC2BR	EYELET (PAIR) - RIGHT HAND LEG / RIGHT HAND 'A' POST
FC3CS	EYELET (SINGLE) / TRANSMISSION TUNNEL, LEFT HAND SIDE
FC4BR	EYELET (PAIR) - RIGHT HAND LEG / LEFT HAND 'A' POST

FOR CONTROL MODULE PIN OUT INFORMATION, UNFOLD PAGE TO LEFT.

The following abbreviations are used to represent values for Control Module Pin-Out data

I	Input	D	Serial and Encoded Data	B+	Battery Voltage	kHz	Frequency x 1000
O	Output	C	CAN (Network)	V	Voltage (DC)	ms	Milliseconds
SG	Signal Ground	S	SCP Network	Hz	Frequency	mV	Millivolts

**CAUTION:** The information on this data page is furnished to aid the user in understanding circuit operation. THIS INFORMATION SHOULD BE USED FOR REFERENCE ONLY.

**NOTE:** The values listed are approximately those that can be expected at the control module connector pins with all circuit connections made and all components connected and fitted. "Active" means a load is applied or a switch is ON; "Inactive" means a load is not applied or a switch is OFF.

Refer to the front of this book for detailed information and illustrations regarding the location and identification of harnesses, relays, grounds, control modules and control module pins.

## CONTROL MODULE PIN OUT INFORMATION

**Fig. 07.2**

### AIR CONDITIONING CONTROL MODULE

Pin	Description	Active	Inactive
I AC1-1	COMPRESSOR CLUTCH STATUS	B+ (ON)	0 V
O AC1-2	HEATER VALVE ACTIVE	B+	0 V
O AC1-3	RH BLOWER MOTOR RELAY ACTIVE	0 V	B+
O AC1-4	LH / RH WINDSHIELD HEATER RELAYS ACTIVATE	0 V	B+
O AC1-5	DOOR MIRROR HEATER RELAY ACTIVATE	0 V	B+
O AC1-16	LH BLOWER MOTOR RELAY ACTIVATE	B+	0 V
O AC1-17	HEATER PUMP RELAY ACTIVATE	0 V	B+
O AC1-18	HEATED BACKLIGHT RELAY ACTIVATE	0 V	B+
I AC2-7	RH BLOWER SPEED FEEDBACK	7.6 V = LOW SPEED	0.83 V = HIGH SPEED
O AC2-8	RH BLOWER SPEED CONTROL DRIVE SIGNAL	1.3 V = LOW SPEED	0 V = HIGH SPEED
I AC2-15	LH BLOWER SPEED FEEDBACK	7.6 V = LOW SPEED	0.83 V = HIGH SPEED
O AC2-16	LH BLOWER SPEED CONTROL DRIVE SIGNAL	1.3 V = LOW SPEED	0 V = HIGH SPEED
O AC3-1	AIR CONDITIONING ELECTRICAL LOAD SIGNAL	B+	0 V
I AC4-7	LOAD INHIBIT	0 V	B+
O AC4-9	COMPRESSOR CLUTCH ON REQUEST	B+	0 V
I AC4-17	REFRIGERANT 4-WAY PRESSURE SWITCH	0 V (2 - 30 BAR)	B+ (OUT OF ACTIVE RANGE)

### ENGINE CONTROL MODULE

Pin	Description	Active	Inactive
I EM80-10	REFRIGERANT 4-WAY PRESSURE SWITCH HIGH PRESSURE	GROUND @ 20 BAR (290 PSI)	
I EM80-11	A/CCM COMPRESSOR CLUTCH REQUEST	B+	GROUND
O EM80-12	ELECTRICAL LOAD INHIBIT	GROUND	B+
I EM80-22	REFRIGERANT 4-WAY PRESSURE SWITCH HIGH PRESSURE	GROUND @ 12 BAR (174 PSI)	
I EM80-23	A/CCM ELECTRICAL LOAD REQUEST (HEATED WINDSHIELD)	B+	GROUND
O EM80-25	AIR CONDITIONING COMPRESSOR RELAY ACTIVATE	GROUND	B+
O EM81-04	PARALLEL (HIGH) SPEED FAN ACTIVATE	GROUND	B+
O EM81-05	SERIES (LOW) SPEED FAN ACTIVATE	GROUND	B+

### COMPONENTS

Component	Connector / Type / Color	Location / Access
AIR CONDITIONING COMPRESSOR CLUTCH	PI36 / 1-WAY SUMITOMO 090 A-TYPE / BLACK	ENGINE COMPARTMENT / A/C COMPRESSOR
AIR CONDITIONING CONTROL MODULE	AC1 / 26-WAY MULTILOCK 47 / GREY AC2 / 16-WAY MULTILOCK 47 / GREY AC3 / 12-WAY MULTILOCK 47 / GREY AC4 / 22-WAY MULTILOCK 47 / GREY	A/C UNIT / RIGHT HAND SIDE
BLOWER MOTOR - LH	AC5 / 15-WAY SUMITOMO 090 HYBRID / GREEN	A/C UNIT / LEFT HAND SIDE
BLOWER MOTOR - RH	AC6 / 15-WAY SUMITOMO 090 HYBRID / GREEN	A/C UNIT / RIGHT HAND SIDE
ENGINE CONTROL MODULE	EM80 / 31-WAY AMP 403 / NATURAL EM81 / 24-WAY AMP 403 / NATURAL EM82 / 17-WAY AMP 403 / NATURAL EM83 / 28-WAY AMP 403 / NATURAL EM84 / 22-WAY AMP 403 / NATURAL EM85 / 12-WAY MULTILOCK 070 / WHITE	ENGINE COMPARTMENT / CONTROL MODULE ENCLOSURE
FUSE BOX - ENGINE COMPARTMENT	LF5 / 10-WAY U.T.A. FUSEBOX / NATURAL LF6 / 10-WAY U.T.A. FUSEBOX / BLACK LF7 / 10-WAY U.T.A. FUSEBOX / GREEN LF8 / 10-WAY U.T.A. FUSEBOX / BLUE LF70 / EYELET	ENGINE COMPARTMENT / LEFT FRONT
FUSE BOX - TRUNK	BT10 / 10-WAY U.T.A. FUSEBOX / NATURAL BT11 / 10-WAY U.T.A. FUSEBOX / BLACK BT12 / 10-WAY U.T.A. FUSEBOX / GREEN BT13 / 10-WAY U.T.A. FUSEBOX / BLUE BT64 / EYELET	TRUNK / ELECTRICAL CARRIER
HEATED BACKLIGHT	RH17 / 1-WAY LUCAR POSILOCK / BLACK RH18 / 1-WAY LUCAR POSILOCK / BLACK	BACKLIGHT / RIGHT HAND SIDE
HEATER PUMP	EM41 / 2-WAY ECONOSEAL III LC / BLACK	ENGINE COMPARTMENT / BULKHEAD, LEFT HAND SIDE
HEATER VALVE	EM43 / 2-WAY ECONOSEAL III LC / WHITE	ENGINE COMPARTMENT / BULKHEAD, LEFT HAND SIDE
MIRROR - DRIVER	DD8 / 12-WAY MULTILOCK 040 / BLACK	DRIVER DOOR
MIRROR - PASSENGER	DP8 / 12-WAY MULTILOCK 040 / BLACK	PASSENGER DOOR
RADIATOR FAN CONTROL RELAY MODULE	LF9 / 8-WAY TRW / BLACK	ADJACENT TO LEFT HAND HORN
RADIATOR FAN - LH	LF13 / 2-WAY REINSHAGEN METRI 630 / BLACK	ENGINE COMPARTMENT / FRONT
RADIATOR FAN - RH	LF12 / 2-WAY REINSHAGEN METRI 630 / BLACK	ENGINE COMPARTMENT / FRONT
REFRIGERANT 4-WAY PRESSURE SWITCH	LF57 / 6-WAY ECONOSEAL III LC / BLACK	ENGINE COMPARTMENT / REARWARD OF RADIATOR
WINDSHIELD HEATER - LH	EM49 / 2-WAY AMP SERIES 187C / GREY	ENGINE COMPARTMENT
WINDSHIELD HEATER - RH	EM48 / 2-WAY AMP SERIES 187C / GREY	ENGINE COMPARTMENT

### RELAYS

Relay	Color / Stripe	Connector / Color	Location / Access
AIR CONDITIONING COMPRESSOR CLUTCH RELAY	BROWN	BUS	LH ENCLOSURE RELAYS
BLOWER MOTOR RELAY - LH	BLACK	AC20 / BLACK	DRIVESHAFT TUNNEL RELAYS
BLOWER MOTOR RELAY - RH	BLACK	AC20 / BLACK	DRIVESHAFT TUNNEL RELAYS
DOOR MIRROR HEATER RELAY	BLACK	FC28 / BLACK	LH FASCIA RELAYS
HEATED BACKLIGHT RELAY (#2)	BROWN	BUS	TRUNK RELAYS
HEATER PUMP RELAY (#1)	BROWN	BUS	ENGINE COMPARTMENT FUSE BOX RELAYS
WINDSHIELD HEATER RELAY - LH	BROWN	EM44 / BROWN	RH ENCLOSURE RELAYS
WINDSHIELD HEATER RELAY - RH	BROWN	EM45 / BROWN	RH ENCLOSURE RELAYS

### HARNESSTO-HARNESSTO CONNECTORS

Connector	Type / Color	Location / Access
AC12	20-WAY MULTILOCK 070 / WHITE	FASCIA TOP CONNECTOR MOUNTING BRACKET / RIGHT HAND SIDE
AC13	20-WAY MULTILOCK 070 / YELLOW	FASCIA BOTTOM CONNECTOR MOUNTING BRACKET / RIGHT HAND SIDE
AC15	20-WAY MULTILOCK 070 / GREY	FASCIA BOTTOM CONNECTOR MOUNTING BRACKET / RIGHT HAND SIDE
BT2	20-WAY MULTILOCK 070 / WHITE	TRUNK / ABOVE RIGHT HAND REAR WHEEL ARCH
BT58	4-WAY ECONOSEAL III HC / BLACK	TRUNK / ABOVE RIGHT HAND REAR WHEEL ARCH
DD1	23-WAY AMP - FORD / BLACK	DRIVER SIDE 'A' POST MOUNTING BRACKET / 'A' POST TRIM
DP1	23-WAY AMP - FORD / BLACK	PASSENGER SIDE 'A' POST / 'A' POST TRIM
EM1	20-WAY MULTILOCK 070 / WHITE	ENGINE COMPARTMENT / ADJACENT TO RIGHT HAND ENCLOSURE
EM2	20-WAY MULTILOCK 070 / YELLOW	ENGINE COMPARTMENT / ADJACENT TO RIGHT HAND ENCLOSURE
LF3	13-WAY ECONOSEAL III LC / WHITE	ENGINE COMPARTMENT / LEFT HAND ENCLOSURE
LF40	13-WAY ECONOSEAL III LC / BLACK	ENGINE COMPARTMENT / LEFT HAND ENCLOSURE
LF60	20-WAY MULTILOCK 070 / WHITE	LEFT HAND 'A' POST CONNECTOR MOUNTING BRACKET / 'A' POST TRIM
PI1	57-WAY SUMITOMO TS090 / BLACK	ENGINE COMPARTMENT / BRACKET ON TOP OF TRANSMISSION
RH2	20-WAY MULTILOCK 070 / WHITE	REAR OF CENTER CONSOLE ASSEMBLY

### GROUND

Ground	Location / Type
EM1AR	EYELET (PAIR) - RIGHT HAND LEG / ENGINE COMPARTMENT, RIGHT HAND ENCLOSURE
EM1BL	EYELET (PAIR) - RIGHT HAND LEG / ENGINE COMPARTMENT, RIGHT HAND ENCLOSURE
EM1BS	EYELET (SINGLE) / ENGINE COMPARTMENT, RIGHT HAND ENCLOSURE
EM2AR	EYELET (PAIR) - RIGHT HAND LEG / ENGINE COMPARTMENT, LEFT HAND ENCLOSURE
EM2BL	EYELET (PAIR) - LEFT HAND LEG / ENGINE COMPARTMENT, LEFT HAND ENCLOSURE
EM2BS	EYELET (SINGLE) / ENGINE COMPARTMENT, LEFT HAND ENCLOSURE
FC2AL	EYELET (PAIR) - LEFT HAND LEG / RIGHT HAND 'A' POST
FC4AL	EYELET (PAIR) - LEFT HAND LEG / LEFT HAND 'A' POST
LF2AL	EYELET (PAIR) - LEFT HAND LEG / ENGINE COMPARTMENT, FORWARD OF LEFT HAND HOOD CATCH
LF2AR	EYELET (PAIR) - RIGHT HAND LEG / ENGINE COMPARTMENT, FORWARD OF LEFT HAND HOOD CATCH
LF2BL	EYELET (PAIR) - LEFT HAND LEG / ENGINE COMPARTMENT, FORWARD OF LEFT HAND HOOD CATCH
RH2S	EYELET (SINGLE) / LEFT HAND REAR QUARTER

The following abbreviations are used to represent values for Control Module Pin-Out data

I	Input	D	Serial and Encoded Data	B+	Battery Voltage	kHz	Frequency x 1000
O	Output	C	CAN (Network)	V	Voltage (DC)	ms	Milliseconds
SG	Signal Ground	S	SCP Network	Hz	Frequency	mV	Millivolts

**CAUTION:** The information on this data page is furnished to aid the user in understanding circuit operation. THIS INFORMATION SHOULD BE USED FOR REFERENCE ONLY.

**NOTE:** The values listed are approximately those that can be expected at the control module connector pins with all circuit connections made and all components connected and fitted. "Active" means a load is applied or a switch is ON; "Inactive" means a load is not applied or a switch is OFF.

FOR CONTROL MODULE PIN OUT INFORMATION, UNFOLD PAGE TO LEFT.

Refer to the front of this book for detailed information and illustrations regarding the location and identification of harnesses, relays, grounds, control modules and control module pins.

**CONTROL MODULE PIN OUT INFORMATION**

**Fig. 08.1**

**MAJOR INSTRUMENT PACK**

Pin	Description	Active	Inactive
I	FC25-01	IGNITION SWITCHED POWER SUPPLY	B+
O	FC25-02	MINOR INSTRUMENT PACK BATTERY POWER SUPPLY	B+
I	FC25-03	ADAPTIVE DAMPING WARNING	GROUND
I	FC25-04	GROUND	GROUND
I	FC25-06	ILLUMINATION SUPPLY	B+
I	FC25-07	TRIP CYCLE	GROUND (MOMENTARY)
I	FC25-08	'A/B' TRIP SELECT	GROUND (MOMENTARY)
I	FC25-09	'ML/KM' SELECT	GROUND (MOMENTARY)
C	FC25-10	CAN NETWORK	15 - 1500 Hz
C	FC25-11	CAN NETWORK	15 - 1500 Hz
S	FC25-13	SCP NETWORK	2 - 1600 Hz
S	FC25-14	SCP NETWORK	2 - 1600 Hz
I	FC25-15	BATTERY POWER SUPPLY	B+
I	FC25-16	GROUND	GROUND
O	FC25-17	MINOR INSTRUMENT PACK ILLUMINATION SUPPLY	B+
I	FC25-18	'CLEAR' SELECT	GROUND (MOMENTARY)
I	FC25-19	'000' SELECT	GROUND (MOMENTARY)
C	FC25-23	CAN NETWORK	15 - 1500 Hz
C	FC25-24	CAN NETWORK	15 - 1500 Hz
O	FC25-25	GROUND REFERENCE	GROUND
O	FC26-1	BATTERY CHARGE WARNING	< 3 V
O	FC26-2	OIL PRESSURE WARNING	< 3 V = < 3 PSI
O	FC26-3	ENGINE SPEED	5 V @ 1000 RPM = 45 Hz; 2000 RPM = 90 Hz
O	FC26-4	ENGINE COOLANT TEMPERATURE	6 V = 90° C
O	FC26-5	VEHICLE SPEED - A/CCM	22 Hz @ 10 MPH (16 KMH); 44 Hz @ 20 MPH (32 KMH) @ B+
O	FC26-6	VEHICLE SPEED - PAS	22 Hz @ 10 MPH (16 KMH); 44 Hz @ 20 MPH (32 KMH) @ B+
O	FC26-7	VEHICLE SPEED - ADAPTIVE DAMPING CONTROL MODULE	22 Hz @ 10 MPH (16 KMH); 44 Hz @ 20 MPH (32 KMH) @ B+
O	FC26-8	BATTERY VOLTAGE GAUGE POSITION FEEDBACK	5 V (MIDPOINT)
O	FC26-9	BATTERY VOLTAGE GAUGE POSITION FEEDBACK	5 V (MIDPOINT)
O	FC26-10	OIL PRESSURE GAUGE POSITION FEEDBACK	5 V = 0 PSI; 3.3 V = NORMAL (MIDPOINT)
O	FC26-11	BATTERY VOLTAGE GAUGE MOVEMENT	3.7 - 5 V (PULSE)
O	FC26-12	BATTERY VOLTAGE GAUGE MOVEMENT	3.7 - 5 V (PULSE)
I	FC26-13	FUEL LEVEL GAUGE FEEDBACK	B+ = EMPTY
O	FC26-14	FUEL LEVEL GAUGE REFERENCE GROUND	GROUND
O	FC26-15	OIL PRESSURE GAUGE POSITION FEEDBACK	5 V = 0 PSI; 3.3 V = NORMAL (MIDPOINT)
I	FC26-16	AIR BAG MIL	GROUND (ON)
O	FC26-17	OIL PRESSURE GAUGE MOVEMENT	3.7 - 5 V (PULSE)
O	FC26-18	OIL PRESSURE GAUGE MOVEMENT	3.7 - 5 V (PULSE)
I	FC26-19	LOW OIL PRESSURE WARNING	> 3 V = > 3 PSI
O	FC26-20	VEHICLE SPEED	22 Hz @ 10 MPH (16 KMH); 44 Hz @ 20 MPH (32 KMH) @ B+
I	FC26-21	DIMMER OVERRIDE	GROUND
I	FC26-22	CHARGE WARNING	B+
I	FC26-23	LOW COOLANT WARNING	GROUND

**MINOR INSTRUMENT PACK**

Pin	Description	Active	Inactive
I	FC79-8	MINOR INSTRUMENT PACK ILLUMINATION SUPPLY	B+
I	FC79-9	OIL PRESSURE GAUGE MOVEMENT	3.7 - 5 V (PULSE)
I	FC79-10	OIL PRESSURE GAUGE MOVEMENT	3.7 - 5 V (PULSE)
I	FC79-11	CHARGE WARNING	< 3 V
I	FC79-12	BATTERY VOLTAGE GAUGE POSITION FEEDBACK	5 V (MIDPOINT)
I	FC79-13	BATTERY VOLTAGE GAUGE POSITION FEEDBACK	5 V (MIDPOINT)
I	FC79-14	BATTERY VOLTAGE GAUGE MOVEMENT	3.7 - 5 V (PULSE)
I	FC79-15	BATTERY VOLTAGE GAUGE MOVEMENT	3.7 - 5 V (PULSE)
I	FC79-16	GROUND	GROUND
I	FC79-17	BATTERY POWER SUPPLY	B+
I	FC79-18	LOW OIL PRESSURE WARNING	GROUND (< 3 PSI)
I	FC79-19	OIL PRESSURE GAUGE POSITION FEEDBACK	5 V = 0 PSI; 3.3 V = NORMAL (MIDPOINT)
I	FC79-20	OIL PRESSURE GAUGE POSITION FEEDBACK	5 V = 0 PSI; 3.3 V = NORMAL (MIDPOINT)

**NOTE:** Refer to the Appendix at the rear of this book for CAN and SCP Network Messages.

The following abbreviations are used to represent values for Control Module Pin-Out data

I	Input	D	Serial and Encoded Data	B+	Battery Voltage	kHz	Frequency x 1000
O	Output	C	CAN (Network)	V	Voltage (DC)	ms	Milliseconds
SG	Signal Ground	S	SCP Network	Hz	Frequency	mV	Millivolts

**CAUTION:** The information on this data page is furnished to aid the user in understanding circuit operation. THIS INFORMATION SHOULD BE USED FOR REFERENCE ONLY.

**NOTE:** The values listed are approximately those that can be expected at the control module connector pins with all circuit connections made and all components connected and fitted. "Active" means a load is applied or a switch is ON; "Inactive" means a load is not applied or a switch is OFF.

**COMPONENTS**

Component	Connector / Type / Color	Location / Access
COOLANT LEVEL SWITCH	EM55 / 2-WAY AMP JUNIOR POWER TIMER / BROWN	ENGINE COMPARTMENT / COOLANT RESERVOIR
FUEL LEVEL SENSOR	FT4 / LUCAR POSILOK / BLACK FT5 / LUCAR POSILOK / BLACK	TRUNK / FUEL TANK
MAJOR INSTRUMENT PACK	FC25 / 26-WAY AMP MICRO QUAD LOCK / BLACK FC26 / 26-WAY AMP MICRO QUAD LOCK / YELLOW	FASCIA
MINOR INSTRUMENT PACK	FC79 / 20-WAY MULTILOCK 040 / BLACK	FASCIA
OIL PRESSURE SWITCH	PI40 / 1-WAY ECONOSEAL ECJ2 / BLACK	ENGINE BLOCK / RIGHT HAND SIDE
TRIP COMPUTER SWITCH PACK	FC27 / 10-WAY AMP MQL / BLACK	FASCIA / DRIVER SIDE
TRIP CYCLE SWITCH (COLUMN SWITCHGEAR)	SC2 / 10-WAY MULTILOCK 070 / YELLOW	STEERING COLUMN

**HARNESSTO-HARNESSTO CONNECTORS**

Connector	Type / Color	Location / Access
BT2	20-WAY MULTILOCK 070 / WHITE	TRUNK / ABOVE RIGHT HAND REAR WHEEL ARCH
EM1	20-WAY MULTILOCK 070 / WHITE	ENGINE COMPARTMENT / ADJACENT TO RIGHT HAND ENCLOSURE
EM2	20-WAY MULTILOCK 070 / YELLOW	ENGINE COMPARTMENT / ADJACENT TO RIGHT HAND ENCLOSURE
FT1	10-WAY MULTILOCK 070 / WHITE	FUEL TANK / REAR
PI1	57-WAY SUMITOMO TS090 / BLACK	ENGINE COMPARTMENT / BRACKET ON TOP OF TRANSMISSION
RH1	20-WAY MULTILOCK 070 / GREY	BEHIND GLOVE BOX

**GROUNDSTO**

Ground	Location / Type
EM1BR	EYELET (PAIR) - RIGHT HAND LEG / ENGINE COMPARTMENT, RIGHT HAND ENCLOSURE
EM2BR	EYELET (PAIR) - RIGHT HAND LEG / ENGINE COMPARTMENT, LEFT HAND ENCLOSURE
FC2BR	EYELET (PAIR) - RIGHT HAND LEG / RIGHT HAND 'A' POST
FC3BL	EYELET (PAIR) - LEFT HAND LEG / TRANSMISSION TUNNEL, LEFT HAND SIDE
FC4BR	EYELET (PAIR) - RIGHT HAND LEG / LEFT HAND 'A' POST

**FOR CONTROL MODULE PIN OUT INFORMATION, UNFOLD PAGE TO LEFT.**

Refer to the front of this book for detailed information and illustrations regarding the location and identification of harnesses, relays, grounds, control modules and control module pins.



CONTROL MODULE PIN OUT INFORMATION

BODY PROCESSOR MODULE

Pin	Description	Active	Inactive
I	FC14-15	IGNITION SWITCHED GROUND SUPPLY	GROUND
I	FC14-32	IGNITION SWITCHED GROUND SUPPLY	GROUND
I	FC14-41	IGNITION SWITCHED GROUND SUPPLY	GROUND
I	FC14-80	BATTERY POWER SUPPLY (LOGIC)	B+
O	FC14-82	AUDIBLE WARNING SPEAKER OUTPUT	AUDIO OUTPUT
O	FC14-83	AUDIBLE WARNING SPEAKER OUTPUT	AUDIO OUTPUT
S	FC14-84	SCP NETWORK	2 - 1600 Hz
S	FC14-85	SCP NETWORK	2 - 1600 Hz
I	FC14-104	BATTERY POWER SUPPLY	B+

NOTE: Refer to the Appendix at the rear of this book for CAN and SCP Network Messages.

**Fig. 08.2**

COMPONENTS

Component	Connector / Type / Color	Location / Access
AUDIBLE WARNING SPEAKER (COLUMN SWITCHGEAR)	SC1 / 12-WAY MULTILOCK 070 / WHITE	STEERING COLUMN / RIGHT HAND SIDE
BODY PROCESSOR MODULE	FC14 / 104-WAY AMP EEEEC / GREY	PASSENGER SIDE FASCIA / AIRBAG BRACKET

FOR CONTROL MODULE PIN OUT INFORMATION, UNFOLD PAGE TO LEFT.

The following abbreviations are used to represent values for Control Module Pin-Out data

I	Input	D	Serial and Encoded Data	B+	Battery Voltage	kHz	Frequency x 1000
O	Output	C	CAN (Network)	V	Voltage (DC)	ms	Milliseconds
SG	Signal Ground	S	SCP Network	Hz	Frequency	mV	Millivolts

CAUTION: The information on this data page is furnished to aid the user in understanding circuit operation. THIS INFORMATION SHOULD BE USED FOR REFERENCE ONLY.

NOTE: The values listed are approximately those that can be expected at the control module connector pins with all circuit connections made and all components connected and fitted. "Active" means a load is applied or a switch is ON; "Inactive" means a load is not applied or a switch is OFF.

Refer to the front of this book for detailed information and illustrations regarding the location and identification of harnesses, relays, grounds, control modules and control module pins.

**CONTROL MODULE PIN OUT INFORMATION**

**Fig. 09.1**

**BODY PROCESSOR MODULE**

Pin	Description	Active	Inactive
O	FC14-1	RH FRONT SIDE LAMP BULB SUPPLY	B+
O	FC14-2	LH FRONT DI BULB SUPPLY	B+ (PULSED)
O	FC14-3	RH FRONT DI BULB SUPPLY	B+ (PULSED)
I	FC14-14	HEADLAMP MAIN BEAM REQUEST	GROUND
I	FC14-15	IGNITION SWITCHED GROUND SUPPLY	GROUND
I	FC14-16	SIDE LAMP REQUEST	GROUND
O	FC14-20	FRONT FOG LAMP RELAY ACTIVATE / STATUS LED	GROUND (LIGHTS ON / LED ON)
O	FC14-27	LH SIDE DI REPEATER SUPPLY (ROW ONLY)	B+
O	FC14-28	RH SIDE DI REPEATER SUPPLY (ROW ONLY)	B+
I	FC14-30	HEADLAMP FLASH REQUEST	GROUND (MOMENTARY)
I	FC14-38	FRONT FOG LAMP SWITCH	GROUND (MOMENTARY)
I	FC14-41	IGNITION GROUND SUPPLY	GROUND
I	FC14-42	DIPPED BEAM REQUEST	GROUND
O	FC14-45	MAIN BEAM RELAY ACTIVATE	GROUND
O	FC14-53	LH FRONT SIDE LAMP SUPPLY	B+ (LIGHT ON)
O	FC14-54	LH SIDE MARKER SUPPLY (NAS ONLY)	B+ (LIGHT ON)
I	FC14-59	HAZARD LAMP REQUEST	GROUND (MOMENTARY)
I	FC14-61	RH DI REQUEST	GROUND
O	FC14-68	DIP BEAM RELAY ACTIVATE	GROUND (LIGHTS ON)
I	FC14-79	BATTERY POWER SUPPLY	B+
I	FC14-80	BATTERY POWER SUPPLY (LOGIC)	B+
O	FC14-81	RH SIDE DI REPEATER SUPPLY (ROW ONLY)	B+ (LIGHTS ON)
S	FC14-84	SCP NETWORK	2 - 1600 Hz
S	FC14-85	SCP NETWORK	2 - 1600 Hz
I	FC14-88	LH DI REQUEST	GROUND
O	FC14-96	HAZARD STATUS INDICATOR	B+ (PULSED)

**MAJOR INSTRUMENT PACK**

Pin	Description	Active	Inactive
S	FC25-13	SCP NETWORK	2 - 1600 Hz
S	FC25-14	SCP NETWORK	2 - 1600 Hz

**NOTE:** Refer to the Appendix at the rear of this book for CAN and SCP Network Messages.

**COMPONENTS**

Component	Connector / Type / Color	Location / Access
BODY PROCESSOR MODULE	FC14 / 104-WAY AMP EEEEC / GREY	PASSENGER SIDE FASCIA / AIRBAG BRACKET
CENTER CONSOLE SWITCH PACK	FC55 / 20-WAY FORD IDC / BLACK	CENTER CONSOLE
FRONT FOG LAMP - LH	LF32 / 2-WAY REINSHAGEN METRI 630 / BLACK	FRONT BUMPER / WHEEL ARCH LINER PANEL
FRONT FOG LAMP - RH	LF22 / 2-WAY REINSHAGEN METRI 630 / BLACK	FRONT BUMPER / WHEEL ARCH LINER PANEL
FRONT LAMP UNIT - LH	LF31 / 6-WAY ECONOSEAL III LC / BLACK	LEFT HAND HEADLAMP ASSEMBLY
FRONT LAMP UNIT - RH	LF21 / 6-WAY ECONOSEAL III LC / BLACK	RIGHT HAND HEADLAMP ASSEMBLY
FUSE BOX - ENGINE COMPARTMENT	LF5 / 10-WAY U.T.A. FUSEBOX / NATURAL LF6 / 10-WAY U.T.A. FUSEBOX / BLACK LF7 / 10-WAY U.T.A. FUSEBOX / GREEN LF8 / 10-WAY U.T.A. FUSEBOX / BLUE LF70 / EYELET	ENGINE COMPARTMENT / LEFT FRONT
LIGHTING STALK (COLUMN SWITCHGEAR)	SC2 / 10-WAY MULTILOCK 070 / YELLOW	STEERING COLUMN
MAJOR INSTRUMENT PACK	FC25 / 26-WAY AMP MICRO QUAD LOCK / BLACK FC26 / 26-WAY AMP MICRO QUAD LOCK / YELLOW LF4 / 2-WAY AMP JUNIOR POWER TIMER / BLACK EL5 / 2-WAY AMP JUNIOR POWER TIMER / BLACK LF11 / 2-WAY AMP JUNIOR POWER TIMER / BLACK LF10 / 2-WAY AMP JUNIOR POWER TIMER / BLACK	FASCIA BEHIND WHEEL ARCH LINER BEHIND WHEEL ARCH LINER BEHIND WHEEL ARCH LINER BEHIND WHEEL ARCH LINER

**RELAYS**

Relay	Color / Stripe	Connector / Color	Location / Access
DIP BEAM RELAY (#5)	BROWN	BUS	ENGINE COMPARTMENT FUSE BOX
FRONT FOG RELAY (#2)	BROWN	BUS	ENGINE COMPARTMENT FUSE BOX
MAIN BEAM RELAY (#3)	BROWN	BUS	ENGINE COMPARTMENT FUSE BOX

**HARNESS-TO-HARNESS CONNECTORS**

Connector	Type / Color	Location / Access
EL6	2-WAY ECONOSEAL III LC / BLACK	ENGINE COMPARTMENT / ADJACENT TO RIGHT HAND ENCLOSURE
EM2	20-WAY MULTILOCK 070 / YELLOW	ENGINE COMPARTMENT / ADJACENT TO RIGHT HAND ENCLOSURE
LF1	20-WAY MULTILOCK 070 / GREY	LEFT HAND 'A' POST CONNECTOR MOUNTING BRACKET / 'A' POST TRIM

**GROUNDS**

Ground	Location / Type
EM1AR	EYELET (PAIR) - RIGHT HAND LEG / ENGINE COMPARTMENT, RIGHT HAND ENCLOSURE
EM2AR	EYELET (PAIR) - RIGHT HAND LEG / ENGINE COMPARTMENT, LEFT HAND ENCLOSURE
FC2BR	EYELET (PAIR) - RIGHT HAND LEG / RIGHT HAND 'A' POST
FC3BL	EYELET (PAIR) - LEFT HAND LEG / TRANSMISSION TUNNEL, LEFT HAND SIDE
FC3BR	EYELET (PAIR) - RIGHT HAND LEG / TRANSMISSION TUNNEL, LEFT HAND SIDE
FC4BR	EYELET (PAIR) - RIGHT HAND LEG / LEFT HAND 'A' POST
LF1AL	EYELET (PAIR) - LEFT HAND LEG / RIGHT HAND HEADLAMP
LF2BR	EYELET (PAIR) - RIGHT HAND LEG / ENGINE COMPARTMENT, FORWARD OF LEFT HAND HOOD CATCH

**FOR CONTROL MODULE PIN OUT INFORMATION, UNFOLD PAGE TO LEFT.**

The following abbreviations are used to represent values for Control Module Pin-Out data

I	Input	D	Serial and Encoded Data	B+	Battery Voltage	kHz	Frequency x 1000
O	Output	C	CAN (Network)	V	Voltage (DC)	ms	Milliseconds
SG	Signal Ground	S	SCP Network	Hz	Frequency	mV	Millivolts

**CAUTION:** The information on this data page is furnished to aid the user in understanding circuit operation. THIS INFORMATION SHOULD BE USED FOR REFERENCE ONLY.

**NOTE:** The values listed are approximately those that can be expected at the control module connector pins with all circuit connections made and all components connected and fitted. "Active" means a load is applied or a switch is ON; "Inactive" means a load is not applied or a switch is OFF.

Refer to the front of this book for detailed information and illustrations regarding the location and identification of harnesses, relays, grounds, control modules and control module pins.

## CONTROL MODULE PIN OUT INFORMATION

**Fig. 09.2**

### BODY PROCESSOR MODULE

Pin	Description	Active	Inactive
I	FC14-12 REAR FOG LAMP REQUEST	GROUND (MOMENTARY)	B+
I	FC14-15 IGNITION SWITCHED GROUND SUPPLY	GROUND	B+
I	FC14-16 SIDE LAMP REQUEST	GROUND	B+
I	FC14-41 IGNITION GROUND SUPPLY	GROUND	B+
I	FC14-42 DIPPED BEAM REQUEST	GROUND	B+
O	FC14-44 REAR FOG LAMP STATUS LED	GROUND (LED ON)	B+
O	FC14-50 LH REAR DI LAMP SUPPLY	B+ (LIGHT ON)	GROUND
I	FC14-61 RH DI REQUEST	GROUND	B+
O	FC14-76 RH REAR DI LAMP SUPPLY	B+ (LIGHTS ON)	GROUND
I	FC14-79 BATTERY POWER SUPPLY	B+	B+
I	FC14-80 BATTERY POWER SUPPLY (LOGIC)	B+	B+
S	FC14-84 SCP NETWORK	2 - 1600 Hz	B+
S	FC14-85 SCP NETWORK	2 - 1600 Hz	B+
I	FC14-88 LH DI REQUEST	GROUND	B+
O	FC14-95 TAIL LAMP RELAY ACTIVATE	GROUND (LIGHTS ON)	B+
I	FC14-104 LIGHTING / MOTORS BATTERY POWER SUPPLY	B+	B+

### LAMP CONTROL MODULE

Pin	Description	Active	Inactive
I	BT18-14 RH STOP LAMP SUPPLY	B+	GROUND
I	BT18-15 LH STOP LAMP SUPPLY	B+	GROUND
I	BT18-16 LH TAIL & SIDE MARKER LAMP SUPPLY	B+	GROUND
I	BT18-17 RH TAIL & SIDE MARKER LAMP SUPPLY	B+	GROUND
O	BT18-18 NUMBER PLATE LAMP SUPPLY	B+	GROUND
O	BT18-19 LH STOP LAMP SUPPLY	B+	GROUND
O	BT18-20 RH STOP LAMP SUPPLY	B+	GROUND
O	BT18-21 LH TAIL LAMP SUPPLY	B+	GROUND
O	BT18-22 RH TAIL LAMP SUPPLY	B+	GROUND
O	BT18-23 SIDE MARKER LAMP SUPPLY	B+	GROUND
I	BT18-24 IGNITION SWITCHED POWER SUPPLY	B+	GROUND
O	BT18-25 SECURITY LIGHTING ON FEEDBACK	B+	GROUND
I	BT18-26 GROUND	GROUND	GROUND

### MAJOR INSTRUMENT PACK

Pin	Description	Active	Inactive
C	FC25-11 CAN NETWORK	15 - 1500 Hz	
S	FC25-13 SCP NETWORK	2 - 1600 Hz	
S	FC25-14 SCP NETWORK	2 - 1600 Hz	
C	FC25-23 CAN NETWORK	15 - 1500 Hz	

### SECURITY AND LOCKING CONTROL MODULE

Pin	Description	Active	Inactive
O	BT40-5 REVERSE LAMP SUPPLY	B+	GROUND
I	BT40-6 BATTERY POWER SUPPLY	B+	B+
O	BT40-7 REAR FOG LAMP RELAY ACTIVATE	GROUND	B+
S	BT40-8 SCP NETWORK	2 - 1600 Hz	
I	BT40-13 GROUND	GROUND	GROUND
I	BT40-14 GROUND	GROUND	GROUND
S	BT40-16 SCP NETWORK	2 - 1600 Hz	
I	BT41-1 SECURITY LIGHTING ON FEEDBACK	B+	GROUND

**NOTE:** Refer to the Appendix at the rear of this book for CAN and SCP Network Messages.

### COMPONENTS

Component	Connector / Type / Color	Location / Access
BODY PROCESSOR MODULE	FC14 / 104-WAY AMP EEEEC / GREY	PASSENGER SIDE FASCIA / AIRBAG BRACKET
BRAKE SWITCH	AC24 / 4-WAY MULTILOCK 070 / WHITE	TOP OF BRAKE PEDAL
CENTER CONSOLE SWITCH PACK	FC55 / 20-WAY FORD IDC / BLACK	CENTER CONSOLE
FUSE BOX - TRUNK	BT10 / 10-WAY U.T.A. FUSEBOX / NATURAL BT11 / 10-WAY U.T.A. FUSEBOX / BLACK BT12 / 10-WAY U.T.A. FUSEBOX / GREEN BT13 / 10-WAY U.T.A. FUSEBOX / BLUE BT64 / EYELET	TRUNK / ELECTRICAL CARRIER
HIGH MOUNT STOP LAMP (CONV)	BL8 / 2-WAY MULTILOCK 070 / WHITE	TRUNK / UNDERSIDE OF LID
HIGH MOUNT STOP LAMP (COUPE)	RH8 / 2-WAY MULTILOCK 070 / WHITE	TRUNK / REARWARD OF SUB WOOFER SPEAKER
LAMP CONTROL MODULE	BT18 / 26-WAY AMP MQS / YELLOW	TRUNK / ELECTRICAL CARRIER
LIGHTING STALK (COLUMN SWITCHGEAR)	SC2 / 10-WAY MULTILOCK 070 / YELLOW	STEERING COLUMN
MAJOR INSTRUMENT PACK	FC25 / 26-WAY AMP MICRO QUAD LOCK / BLACK FC26 / 26-WAY AMP MICRO QUAD LOCK / YELLOW	FASCIA
NUMBER PLATE LAMP - LH	BL4 / 2-WAY AMP JUNIOR POWER TIMER / BLACK	TRUNK LID / LINER
NUMBER PLATE LAMP - RH	BL5 / 2-WAY AMP JUNIOR POWER TIMER / BLACK	TRUNK LID / LINER
SECURITY AND LOCKING CONTROL MODULE	BT40 / 16-WAY FORD 2.8 TIMER / BLACK BT41 / 26-WAY FORD IDC / BLACK RH20 / COAXIAL CONNECTOR	TRUNK / ELECTRICAL CARRIER
REAR SIDE MARKER - LH (NAS ONLY)	BT27 / 2-WAY AMP JUNIOR POWER TIMER / BLACK	TRUNK / LEFT HAND SIDE
REAR SIDE MARKER - RH (NAS ONLY)	BT26 / 2-WAY AMP JUNIOR POWER TIMER / BLACK	TRUNK / RIGHT HAND SIDE
TAIL LAMP UNIT - LH	BT31 / 7-WAY FORD 2.8 TIMER / BLACK	TRUNK / LEFT HAND SIDE
TAIL LAMP UNIT - RH	BT30 / 7-WAY FORD 2.8 TIMER / BLACK	TRUNK / RIGHT HAND SIDE

### RELAYS

Relay	Color / Stripe	Connector / Color	Location / Access
REAR FOG RELAY (#1)	BROWN	BUS	TRUNK FUSE BOX
STOP LAMP RELAY (#5)	BROWN	BUS	TRUNK FUSE BOX
TAIL LAMP RELAY (#3)	BROWN	BUS	TRUNK FUSE BOX

### HARNESS-TO-HARNESS CONNECTORS

Connector	Type / Color	Location / Access
AC13	20-WAY MULTILOCK 070 / YELLOW	FASCIA BOTTOM CONNECTOR MOUNTING BRACKET / RIGHT HAND SIDE
BB1	3-WAY MULTILOCK 070 / YELLOW	TRUNK / ABOVE RIGHT HAND REAR WHEEL ARCH
BL1	4-WAY MULTILOCK 070 / WHITE	TRUNK / ABOVE RIGHT HAND REAR WHEEL ARCH
BT1	20-WAY MULTILOCK 070 / WHITE	TRUNK / ABOVE RIGHT HAND REAR WHEEL ARCH
BT2	20-WAY MULTILOCK 070 / WHITE	TRUNK / ABOVE RIGHT HAND REAR WHEEL ARCH
RH1	20-WAY MULTILOCK 070 / GREY	BEHIND GLOVE BOX
RH2	20-WAY MULTILOCK 070 / WHITE	REAR OF CENTER CONSOLE ASSEMBLY

### GROUNDINGS

Ground	Location / Type
BT1AR	EYELET (PAIR) - RIGHT HAND LEG / ADJACENT TO BATTERY
BT2AR	EYELET (PAIR) - RIGHT HAND LEG / TRUNK, RIGHT REAR
BT3S	EYELET (SINGLE) / TRUNK, LEFT REAR
FC1BL	EYELET (PAIR) - LEFT HAND LEG / TRANSMISSION TUNNEL, RIGHT HAND SIDE
FC3BL	EYELET (PAIR) - LEFT HAND LEG / TRANSMISSION TUNNEL, LEFT HAND SIDE
FC3BR	EYELET (PAIR) - RIGHT HAND LEG / TRANSMISSION TUNNEL, LEFT HAND SIDE
RH1S	EYELET (SINGLE) / RIGHT HAND REAR QUARTER

FOR CONTROL MODULE PIN OUT INFORMATION, UNFOLD PAGE TO LEFT.

The following abbreviations are used to represent values for Control Module Pin-Out data

I	Input	D	Serial and Encoded Data	B+	Battery Voltage	kHz	Frequency x 1000
O	Output	C	CAN (Network)	V	Voltage (DC)	ms	Milliseconds
SG	Signal Ground	S	SCP Network	Hz	Frequency	mV	Millivolts

**CAUTION:** The information on this data page is furnished to aid the user in understanding circuit operation. THIS INFORMATION SHOULD BE USED FOR REFERENCE ONLY.

**NOTE:** The values listed are approximately those that can be expected at the control module connector pins with all circuit connections made and all components connected and fitted. "Active" means a load is applied or a switch is ON; "Inactive" means a load is not applied or a switch is OFF.

Refer to the front of this book for detailed information and illustrations regarding the location and identification of harnesses, relays, grounds, control modules and control module pins.

## Fig. 09.3

### COMPONENTS

#### Component

HEADLAMP LEVELING ACTUATOR – LH  
HEADLAMP LEVELING ACTUATOR – RH  
LEVELING SWITCH (CENTER CONSOLE SWITCH PACK)

#### Connector / Type / Color

LF34 / 3-WAY REINSHAGEN / BLACK  
LF24 / 3-WAY REINSHAGEN / BLACK  
FC55 / 20-WAY FORD IDC / BLACK

#### Location / Access

HEADLAMP ASSEMBLY / REAR  
HEADLAMP ASSEMBLY / REAR  
CENTER CONSOLE SWITCH PACK

### HARNESS-TO-HARNESS CONNECTORS

#### Connector

LF60

#### Type / Color

20-WAY MULTILOCK 070 / WHITE

#### Location / Access

LEFT HAND 'A' POST CONNECTOR MOUNTING BRACKET / 'A' POST TRIM

### GROUND

#### Ground

FC3BR  
LF1AL  
LF2BR

#### Location / Type

EYELET (PAIR) – RIGHT HAND LEG / TRANSMISSION TUNNEL, LEFT HAND SIDE  
EYELET (PAIR) – LEFT HAND LEG / RIGHT HAND HEADLAMP  
EYELET (PAIR) – RIGHT HAND LEG / ENGINE COMPARTMENT, FORWARD OF LEFT HAND HOOD CATCH

Refer to the front of this book for detailed information and illustrations regarding the location and identification of harnesses, relays, grounds, control modules and control module pins.

**CONTROL MODULE PIN OUT INFORMATION**

**Fig. 10.1**

**DRIVER DOOR CONTROL MODULE**

Pin	Description	Active	Inactive
I DD10-1	BATTERY POWER SUPPLY	B+	B+
I DD10-8	LOGIC GROUND	GROUND	GROUND
S DD10-9	SCP NETWORK	2 - 1600 Hz	
O DD10-14	DRIVER DOOR PUDDLE LAMP SUPPLY	B+	GROUND
S DD10-16	SCP NETWORK	2 - 1600 Hz	
I DD10-17	POWER GROUND	GROUND	GROUND
I DD11-4	DRIVER DOOR LOCK BARREL UNLOCK REQUEST	B+ (MOMENTARY)	GROUND
I DD11-12	DRIVER DOOR LOCK BARREL LOCK REQUEST	B+ (MOMENTARY)	GROUND
I DD11-20	DRIVER DOOR SWITCH	GROUND (DOOR OPEN)	B+

**PASSENGER DOOR CONTROL MODULE**

Pin	Description	Active	Inactive
I DP10-1	BATTERY POWER SUPPLY	B+	B+
I DP10-8	LOGIC GROUND	GROUND	GROUND
S DP10-9	SCP NETWORK	2 - 1600 Hz	
O DP10-14	PASSENGER DOOR PUDDLE LAMP SUPPLY	B+ (LIGHT ON)	GROUND
S DP10-16	SCP NETWORK	2 - 1600 Hz	
I DP10-17	POWER GROUND	GROUND	GROUND
I DP11-20	PASSENGER DOOR SWITCH	GROUND (DOOR OPEN)	B+

**BODY PROCESSOR MODULE**

Pin	Description	Active	Inactive
I FC14-15	IGNITION SWITCHED GROUND SUPPLY	GROUND	GROUND
O FC14-24	FOOTWELL / INTERIOR LAMP SUPPLY	B+	GROUND
I FC14-32	IGNITION SWITCHED GROUND SUPPLY	GROUND	GROUND
I FC14-41	IGNITION GROUND SUPPLY	GROUND	
I FC14-67	KEY IN IGNITION	GROUND (KEY IN)	B+
O FC14-74	INTERIOR LAMP FADE 2 OUTPUT	B+ (FADES TO 0 V)	
I FC14-80	BATTERY POWER SUPPLY (LOGIC)	B+	B+
S FC14-84	SCP NETWORK	2 - 1600 Hz	
S FC14-85	SCP NETWORK	2 - 1600 Hz	
O FC14-101	TRUNK / GLOVE BOX / VANITY LAMP POWER SUPPLY	B+	GROUND
I FC14-104	LIGHTING / MOTORS BATTERY POWER SUPPLY	B+	B+

**NOTE:** Refer to the Appendix at the rear of this book for CAN and SCP Network Messages.

**COMPONENTS**

Component	Connector / Type / Color	Location / Access
BODY PROCESSOR MODULE	FC14 / 104-WAY AMP EEEEC / GREY	PASSENGER SIDE FASCIA / AIRBAG BRACKET
DIODE (BT29) - TRUNK SWITCH	BT29 / DIODE	TRUNK / ADJACENT TO BATTERY
DOOR CONTROL MODULE - DRIVER	DD10 / 22-WAY FORD 2.8 TIMER / BLUE DD11 / 22-WAY FORD 2.8 TIMER / BLACK	DRIVER DOOR / DOOR CASING
DOOR CONTROL MODULE - PASSENGER	DP10 / 22-WAY FORD 2.8 TIMER / BLUE DP11 / 22-WAY FORD 2.8 TIMER / BLACK	PASSENGER DOOR / DOOR CASING
DOOR LOCK SWITCHES - DRIVER	DD3 / 13-WAY ECONOSEAL III LC / BLACK	DRIVER DOOR / DOOR CASING
DOOR SWITCH - DRIVER	DD3 / 13-WAY ECONOSEAL III LC / BLACK	DRIVER DOOR / DOOR CASING
DOOR SWITCH - PASSENGER	DP3 / 13-WAY ECONOSEAL III LC / BLACK	PASSENGER DOOR / DOOR CASING
FOOTWELL LAMP - LH	FC31 / 2-WAY AMP JUNIOR POWER TIMER / BLACK	LEFT HAND FOOTWELL
FOOTWELL LAMP - RH	FC32 / 2-WAY AMP JUNIOR POWER TIMER / BLACK	RIGHT HAND FOOTWELL
GLOVE BOX LAMP	FC33 / 1-WAY LUCAR STRAIGHT / CLEAR FC34 / 1-WAY LUCAR STRAIGHT / CLEAR	GLOVE BOX
IGNITION SWITCH (KEY-IN SWITCH)	FC4 / 8-WAY MULTILOCK 070 / WHITE	STEERING COLUMN
PUDDLE LAMP - DRIVER DOOR	DD14 / 2-WAY AMP JUNIOR POWER TIMER / BLACK	DRIVER DOOR
PUDDLE LAMP - PASSENGER DOOR	DP14 / 2-WAY AMP JUNIOR POWER TIMER / BLACK	PASSENGER DOOR
REAR INTERIOR LAMP (COUPE ONLY)	RH3 / 2-WAY AMP JUNIOR POWER TIMER / WHITE	REAR CENTER OF HEAD LINING
ROOF CONSOLE	RF10 / 6-WAY MULTILOCK 070 / GREY	INTERIOR ROOF
TRUNK LAMP - LH	BT56 / 2-WAY AMP JUNIOR POWER TIMER / WHITE	TRUNK / LEFT HAND SIDE
TRUNK LAMP - RH	BT59 / 2-WAY AMP JUNIOR POWER TIMER / WHITE	TRUNK / RIGHT HAND SIDE
TRUNK SWITCH	BT46 / 2-WAY AUGAT 1.6 / BLACK	TRUNK
VANITY LAMP - LH	RF8 / 3-WAY MULTILOCK 070 / YELLOW	SUN VISOR
VANITY LAMP - RH	RF7 / 3-WAY MULTILOCK 070 / YELLOW	SUN VISOR

**HARNESSTO-HARNESSTO CONNECTORS**

Connector	Type / Color	Location / Access
BT1	20-WAY MULTILOCK 070 / WHITE	TRUNK / ABOVE RIGHT HAND REAR WHEEL ARCH
DD1	23-WAY AMP - FORD / BLACK	DRIVER SIDE 'A' POST MOUNTING BRACKET / 'A' POST TRIM
DP1	23-WAY AMP - FORD / BLACK	PASSENGER SIDE 'A' POST / 'A' POST TRIM
RF1	18-WAY MULTILOCK 070 / YELLOW	RIGHT HAND 'A' POST CONNECTOR MOUNTING BRACKET / 'A' POST TRIM
RH2	20-WAY MULTILOCK 070 / WHITE	REAR OF CENTER CONSOLE ASSEMBLY

**GROUNDS**

Ground	Location / Type
BT1AR	EYELET (PAIR) - RIGHT HAND LEG / ADJACENT TO BATTERY
FC2AL	EYELET (PAIR) - LEFT HAND LEG / RIGHT HAND 'A' POST
FC2AR	EYELET (PAIR) - RIGHT HAND LEG / RIGHT HAND 'A' POST
FC2BL	EYELET (PAIR) - LEFT HAND LEG / RIGHT HAND 'A' POST
FC2BR	EYELET (PAIR) - RIGHT HAND LEG / RIGHT HAND 'A' POST
FC3BL	EYELET (PAIR) - LEFT HAND LEG / TRANSMISSION TUNNEL, LEFT HAND SIDE
FC3BR	EYELET (PAIR) - RIGHT HAND LEG / TRANSMISSION TUNNEL, LEFT HAND SIDE
FC4AL	EYELET (PAIR) - LEFT HAND LEG / LEFT HAND 'A' POST
FC4AR	EYELET (PAIR) - RIGHT HAND LEG / LEFT HAND 'A' POST
FC4BL	EYELET (PAIR) - LEFT HAND LEG / LEFT HAND 'A' POST
FC4BR	EYELET (PAIR) - RIGHT HAND LEG / LEFT HAND 'A' POST
RH1S	EYELET (SINGLE) / RIGHT HAND REAR QUARTER

**FOR CONTROL MODULE PIN OUT INFORMATION, UNFOLD PAGE TO LEFT.**

The following abbreviations are used to represent values for Control Module Pin-Out data

I	Input	D	Serial and Encoded Data	B+	Battery Voltage	kHz	Frequency x 1000
O	Output	C	CAN (Network)	V	Voltage (DC)	ms	Milliseconds
SG	Signal Ground	S	SCP Network	Hz	Frequency	mV	Millivolts

**CAUTION:** The information on this data page is furnished to aid the user in understanding circuit operation. THIS INFORMATION SHOULD BE USED FOR REFERENCE ONLY.

**NOTE:** The values listed are approximately those that can be expected at the control module connector pins with all circuit connections made and all components connected and fitted. "Active" means a load is applied or a switch is ON; "Inactive" means a load is not applied or a switch is OFF.

Refer to the front of this book for detailed information and illustrations regarding the location and identification of harnesses, relays, grounds, control modules and control module pins.

**CONTROL MODULE PIN OUT INFORMATION**

**DIMMER MODULE**

Pin	Description	Active	Inactive
O	FC23-1 MAJOR INSTRUMENT PACK ILLUMINATION BULB SUPPLY	B+ (LIGHTS ON)	GROUND
O	FC23-2 MAJOR INSTRUMENT PACK ILLUMINATION BULB SUPPLY	B+ (LIGHTS ON)	GROUND
I	FC23-3 IGNITION SWITCHED GROUND SUPPLY	GROUND	
I	FC23-4 SIDE LAMPS ON REQUEST	GROUND	
I	FC23-5 DIMMER POTENTIOMETER FEEDBACK VOLTAGE	1.3 V = DIM; 4 V = BRIGHT	
O	FC23-6 DIMMER POTENTIOMETER REFERENCE GROUND	GROUND	GROUND
O	FC23-7 GENERAL ILLUMINATION BULB SUPPLY	B+ (LIGHTS ON)	
O	FC23-8 GENERAL ILLUMINATION BULB SUPPLY	B+ (LIGHTS ON)	
I	FC23-9 GROUND SUPPLY	GROUND	
I	FC23-10 BATTERY POWER SUPPLY	B+	B+
I	FC23-11 BATTERY POWER SUPPLY	B+	B+
O	FC23-12 DIMMER POTENTIOMETER REFERENCE VOLTAGE	4 V	0 V

**Fig. 10.2**

**COMPONENTS**

Component	Connector / Type / Color	Location / Access
AIR CONDITIONING CONTROL PANEL	FC43 / 12-WAY MULTILOCK 040 / BLUE	CENTER CONSOLE
CENTER CONSOLE SWITCH PACK	FC55 / 20-WAY FORD IDC / BLACK	CENTER CONSOLE
CIGAR LIGHTER	FC42 / 2-WAY AMP / METALLIC FC59 / LUCAR POSILOK / BLACK	FORWARD OF GEAR SELECTOR
CONVERTIBLE TOP SWITCH	FC62 / 10-WAY AMP MQL / BLACK	FORWARD OF GEAR SELECTOR
SPEED CONTROL ON / OFF SWITCH	FC63 / 10-WAY AMP MQL / NATURAL	REARWARD OF GEAR SELECTOR
DIMMER CONTROL (COLUMN SWITCHGEAR)	SC11 / 6-WAY MULTILOCK 070 / WHITE	STEERING COLUMN COWL
DIMMER MODULE	FC23 / 12-WAY MULTILOCK 040 / BLACK	ADJACENT TO RIGHT HAND FASCIA FUSE BOX
GEAR SELECTOR ILLUMINATION MODULE	FC88 / 10-WAY MULTILOCK 070 / WHITE	FRONT OF GEAR SELECTOR ASSEMBLY
LIGHTING STALK (COLUMN SWITCHGEAR)	SC2 / 10-WAY MULTILOCK 070 / YELLOW	STEERING COLUMN
MAJOR INSTRUMENT PACK	FC25 / 26-WAY AMP MICRO QUAD LOCK / BLACK FC26 / 26-WAY AMP MICRO QUAD LOCK / YELLOW	FASCIA
MINOR INSTRUMENT PACK	FC79 / 20-WAY MULTILOCK 040 / BLACK	FASCIA
MODE SWITCH (TRANSMISSION)	FC35 / 10-WAY AMP MQL / BLACK	REARWARD OF GEAR SELECTOR
NAVIGATION CONTROL MODULE	IC7 / 8-WAY ALPINE / BLACK IC22 / 16-WAY AMP ML42 / BLACK IC23 / 24-WAY AMP ML42 / BLACK	TRUNK / RIGHT HAND SIDE
NAVIGATION DISPLAY	FC97 / 12-WAY AMP ML42 / BLACK FC98 / 16-WAY AMP ML42 / BLACK	BEHIND NAVIGATION DISPLAY
RADIO / CASSETTE HEAD UNIT	IC8 / 8-WAY ALPINE / BLACK IC19 / 12-WAY MULTILOCK 070 / WHITE IC20 / 26-WAY MQS / YELLOW	CENTER CONSOLE
SWITCH PACK - DRIVER DOOR	DD17 / 20-WAY MULTILOCK 040 / BLACK	DRIVER DOOR
SWITCH PACK - DRIVER DOOR MEMORY	DD5 / 10-WAY AMP MQL / BLACK	DRIVER DOOR
SWITCH PACK - PASSENGER DOOR	DP17 / 8-WAY MULTILOCK 040 / BLACK	PASSENGER DOOR
TRIP COMPUTER SWITCH PACK	FC27 / 10-WAY AMP MQL / BLACK	FASCIA / DRIVER SIDE
TRUNK AND FUEL FILL RELEASE SWITCH	FC41 / 10-WAY AMP MQL / NATURAL	FASCIA / DRIVER SIDE
VALET SWITCH	FC67 / 10-WAY AMP MQL / BLACK	DRIVER KNEE BOLSTER

**HARNESS-TO-HARNESS CONNECTORS**

Connector	Type / Color	Location / Access
AC15	20-WAY MULTILOCK 070 / GREY	FASCIA BOTTOM CONNECTOR MOUNTING BRACKET / RIGHT HAND SIDE
DD1	23-WAY AMP - FORD / BLACK	DRIVER SIDE 'A' POST MOUNTING BRACKET / 'A' POST TRIM
DP1	23-WAY AMP - FORD / BLACK	PASSENGER SIDE 'A' POST / 'A' POST TRIM
IC1	20-WAY MULTILOCK 070 / YELLOW	BELOW CENTER CONSOLE GLOVE BOX
SC3	12-WAY MULTILOCK 070 / GREY	RIGHT HAND SIDE OF STEERING COLUMN

**GROUNDS**

Ground	Location / Type
CE2	EYELET (SINGLE) / ABOVE RIGHT HAND SIDE OF TRANSMISSION TUNNEL
FC2AL	EYELET (PAIR) - LEFT HAND LEG / RIGHT HAND 'A' POST
FC2BL	EYELET (PAIR) - LEFT HAND LEG / RIGHT HAND 'A' POST
FC2BR	EYELET (PAIR) - RIGHT HAND LEG / RIGHT HAND 'A' POST
FC3BL	EYELET (PAIR) - LEFT HAND LEG / TRANSMISSION TUNNEL, LEFT HAND SIDE
FC3BR	EYELET (PAIR) - RIGHT HAND LEG / TRANSMISSION TUNNEL, LEFT HAND SIDE
FC4AL	EYELET (PAIR) - LEFT HAND LEG / LEFT HAND 'A' POST
FC4BL	EYELET (PAIR) - LEFT HAND LEG / LEFT HAND 'A' POST
FC4BR	EYELET (PAIR) - RIGHT HAND LEG / LEFT HAND 'A' POST

FOR CONTROL MODULE PIN OUT INFORMATION, UNFOLD PAGE TO LEFT.

The following abbreviations are used to represent values for Control Module Pin-Out data

I	Input	D	Serial and Encoded Data	B+	Battery Voltage	kHz	Frequency x 1000
O	Output	C	CAN (Network)	V	Voltage (DC)	ms	Milliseconds
SG	Signal Ground	S	SCP Network	Hz	Frequency	mV	Millivolts

**CAUTION:** The information on this data page is furnished to aid the user in understanding circuit operation. THIS INFORMATION SHOULD BE USED FOR REFERENCE ONLY.

**NOTE:** The values listed are approximately those that can be expected at the control module connector pins with all circuit connections made and all components connected and fitted. "Active" means a load is applied or a switch is ON; "Inactive" means a load is not applied or a switch is OFF.

Refer to the front of this book for detailed information and illustrations regarding the location and identification of harnesses, relays, grounds, control modules and control module pins.

**CONTROL MODULE PIN OUT INFORMATION**

**Fig. 11.1**

**BODY PROCESSOR MODULE**

Pin	Description	Active	Inactive
I	FC14-11	AUTO TILT REQUEST	GROUND
I	FC14-15	IGNITION SWITCHED GROUND SUPPLY	GROUND
I	FC14-25	COLUMN MOTOR GROUND SUPPLY	GROUND
I	FC14-32	IGNITION SWITCHED GROUND SUPPLY	GROUND
O	FC14-40	COLUMN MOTOR POTENTIOMETER REFERENCE VOLTAGE	5 V
I	FC14-41	IGNITION GROUND SUPPLY	GROUND
O	FC14-52	COLUMN REACH MOTOR SUPPLY	B+
I	FC14-58	NOT-IN-PARK	GROUND (R,N,D,4,3,2)
I	FC14-66	COLUMN REACH MOTOR POTENTIOMETER FEEDBACK	0.5 V (OUT); 4 V (IN)
I	FC14-67	KEY IN IGNITION	GROUND (KEY IN)
O	FC14-78	COLUMN REACH MOTOR SUPPLY	B+
I	FC14-80	BATTERY POWER SUPPLY (LOGIC)	B+
S	FC14-84	SCP NETWORK	2 – 1600 Hz
S	FC14-85	SCP NETWORK	2 – 1600 Hz
I	FC14-87	COLUMN MOVEMENT REQUEST	UP = 10.1 V, DOWN = 12.1 V, RETRACT = 8.5 V, EXTEND = 6.8 V
O	FC14-90	COLUMN TILT MOTOR POTENTIOMETER REFERENCE GROUND	GROUND
O	FC14-91	COLUMN REACH MOTOR POTENTIOMETER REFERENCE GROUND	GROUND
I	FC14-93	COLUMN TILT MOTOR POTENTIOMETER FEEDBACK	UP = 4 V, DOWN = 0.5 V
O	FC14-99	COLUMN TILT MOTOR SUPPLY	B+
O	FC14-100	COLUMN TILT MOTOR SUPPLY	B+
I	FC14-102	COLUMN MOVEMENT MOTORS BATTERY POWER SUPPLY	B+

**DRIVER DOOR CONTROL MODULE**

Pin	Description	Active	Inactive
I	DD10-1	BATTERY POWER SUPPLY	B+
I	DD10-8	LOGIC GROUND	GROUND
S	DD10-9	SCP NETWORK	2 – 1600 Hz
S	DD10-16	SCP NETWORK	2 – 1600 Hz
I	DD10-17	POWER GROUND	GROUND
O	DD11-2	SEAT MEMORY STATUS LED	GROUND (LED ON)
I	DD11-6	MEMORY SET REQUEST	B+
I	DD11-20	DRIVER DOOR SWITCH	GROUND (DOOR OPEN)
I	DD11-21	MEMORY 1 RECALL REQUEST	B+ (MOMENTARY)
I	DD11-22	MEMORY 2 RECALL REQUEST	B+ (MOMENTARY)

**NOTE:** Refer to the Appendix at the rear of this book for CAN and SCP Network Messages.

**COMPONENTS**

Component	Connector / Type / Color	Location / Access
AUTO TILT SWITCH (COLUMN SWITCHGEAR)	SC9 / 8-WAY GROTE AND HARTMAN MDK / BLACK	STEERING COLUMN / LEFT HAND SIDE
BODY PROCESSOR MODULE	FC14 / 104-WAY AMP EEEEC / GREY	PASSENGER SIDE FASCIA / AIRBAG BRACKET
COLUMN JOY STICK (COLUMN SWITCHGEAR)	SC9 / 8-WAY GROTE AND HARTMAN MDK / BLACK	STEERING COLUMN / LEFT HAND SIDE
DOOR CONTROL MODULE – DRIVER	DD10 / 22-WAY FORD 2.8 TIMER / BLUE DD11 / 22-WAY FORD 2.8 TIMER / BLACK DD3 / 13-WAY ECONOSEAL III LC / BLACK	DRIVER DOOR / DOOR CASING DRIVER DOOR / DOOR CASING
DOOR SWITCH – DRIVER	FC4 / 8-WAY MULTILOCK 070 / WHITE	DRIVER DOOR / DOOR CASING
IGNITION SWITCH (KEY-IN SWITCH)	FC87 / 3-WAY MULTILOCK 070 / WHITE	STEERING COLUMN
NOT-IN-PARK MICROSWITCH	FC67 / 3-WAY MULTILOCK 070 / WHITE	GEAR SELECTOR ASSEMBLY
STEERING COLUMN MOTORS	FC60 / 6-WAY MULTILOCK 070 / WHITE FC61 / 8-WAY MULTILOCK 070 / YELLOW	STEERING COLUMN
SWITCH PACK – DRIVER DOOR MEMORY	DD5 / 10-WAY AMP MQL / BLACK	DRIVER DOOR

**HARNESSTO-HARNESSTO CONNECTORS**

Connector	Type / Color	Location / Access
AC14	14-WAY MULTILOCK 070 / GREY	FASCIA BOTTOM CONNECTOR MOUNTING BRACKET / RIGHT HAND SIDE
DD1	23-WAY AMP – FORD / BLACK	DRIVER SIDE 'A' POST MOUNTING BRACKET / 'A' POST TRIM
SC2	10-WAY MULTILOCK 070 / YELLOW	ADJACENT TO STEERING COLUMN MOTOR
SC3	12-WAY MULTILOCK 070 / GREY	RIGHT HAND SIDE OF STEERING COLUMN

**GROUNDS**

Ground	Location / Type
FC2AR	EYELET (PAIR) – RIGHT HAND LEG / RIGHT HAND 'A' POST
FC2BR	EYELET (PAIR) – RIGHT HAND LEG / RIGHT HAND 'A' POST
FC3BL	EYELET (PAIR) – LEFT HAND LEG / TRANSMISSION TUNNEL, LEFT HAND SIDE
FC3BR	EYELET (PAIR) – RIGHT HAND LEG / TRANSMISSION TUNNEL, LEFT HAND SIDE
FC4AR	EYELET (PAIR) – RIGHT HAND LEG / LEFT HAND 'A' POST
FC4BR	EYELET (PAIR) – RIGHT HAND LEG / LEFT HAND 'A' POST

**FOR CONTROL MODULE PIN OUT INFORMATION, UNFOLD PAGE TO LEFT.**

The following abbreviations are used to represent values for Control Module Pin-Out data

I	Input	D	Serial and Encoded Data	B+	Battery Voltage	kHz	Frequency x 1000
O	Output	C	CAN (Network)	V	Voltage (DC)	ms	Milliseconds
SG	Signal Ground	S	SCP Network	Hz	Frequency	mV	Millivolts

**CAUTION:** The information on this data page is furnished to aid the user in understanding circuit operation. THIS INFORMATION SHOULD BE USED FOR REFERENCE ONLY.

**NOTE:** The values listed are approximately those that can be expected at the control module connector pins with all circuit connections made and all components connected and fitted. "Active" means a load is applied or a switch is ON; "Inactive" means a load is not applied or a switch is OFF.

Refer to the front of this book for detailed information and illustrations regarding the location and identification of harnesses, relays, grounds, control modules and control module pins.

**Fig. 11.2**

**CONTROL MODULE PIN OUT INFORMATION**

**BODY PROCESSOR MODULE**

Pin	Description	Active	Inactive
I FC14-15	IGNITION SWITCHED GROUND SUPPLY	GROUND	
I FC14-32	IGNITION SWITCHED GROUND SUPPLY	GROUND	GROUND
I FC14-41	IGNITION GROUND SUPPLY	GROUND	
I FC14-58	NOT-IN-PARK	GROUND (R,N,D,4,3,2)	B+ (PARK)
I FC14-80	BATTERY POWER SUPPLY (LOGIC)	B+	B+
S FC14-84	SCP NETWORK	2 - 1600 Hz	
S FC14-85	SCP NETWORK	2 - 1600 Hz	

**DRIVER DOOR CONTROL MODULE**

Pin	Description	Active	Inactive
I DD10-1	BATTERY POWER SUPPLY	B+	
O DD10-2	DRIVER DOOR MIRROR VERTICAL / HORIZONTAL MOTOR COMMON SUPPLY	B+ = LEFT / DOWN; GROUND = RIGHT / UP	
O DD10-3	DRIVER DOOR MIRROR HORIZONTAL MOVEMENT MOTOR	B+ = RIGHT	GROUND = LEFT
O DD10-4	DRIVER DOOR MIRROR VERTICAL MOVEMENT MOTOR	B+ = UP	GROUND = DOWN
I DD10-8	LOGIC GROUND	GROUND	GROUND
S DD10-9	SCP NETWORK	2 - 1600 Hz	
S DD10-16	SCP NETWORK	2 - 1600 Hz	
I DD10-17	POWER GROUND	GROUND	GROUND
O DD10-20	DRIVER DOOR MIRROR POTENTIOMETER COMMON REFERENCE VOLTAGE	B+	
I DD10-21	DRIVER DOOR MIRROR POTENTIOMETER HORIZONTAL POSITION FEEDBACK	1 V = LEFT; 8 V = RIGHT	
I DD10-22	DRIVER DOOR MIRROR POTENTIOMETER VERTICAL POSITION FEEDBACK	1 V = DOWN; 8 V = UP	
I DD11-1	MIRROR SELECT	B+ = UP / RIGHT	GROUND = DOWN / LEFT
O DD11-2	SEAT MEMORY STATUS LED	GROUND (LED ON)	B+
I DD11-3	RH VERTICAL MOVEMENT REQUEST	B+ = DOWN	GROUND = UP
I DD11-6	MEMORY SET REQUEST	B+	
I DD11-9	RH HORIZONTAL MOVEMENT REQUEST	B+ = LEFT	GROUND = RIGHT
I DD11-10	LH HORIZONTAL MOVEMENT REQUEST	B+ = LEFT	GROUND = RIGHT
I DD11-17	LH VERTICAL MOVEMENT REQUEST	B+ = DOWN	GROUND = UP
I DD11-20	DRIVER DOOR SWITCH	GROUND (DOOR OPEN)	B+
I DD11-21	MEMORY 1 RECALL REQUEST	B+ (MOMENTARY)	GROUND
I DD11-22	MEMORY 2 RECALL REQUEST	B+ (MOMENTARY)	GROUND

**MAJOR INSTRUMENT PACK**

Pin	Description	Active	Inactive
C FC25-11	CAN NETWORK	15 - 1500 Hz	
S FC25-13	SCP NETWORK	2 - 1600 Hz	
S FC25-14	SCP NETWORK	2 - 1600 Hz	
C FC25-23	CAN NETWORK	15 - 1500 Hz	

**PASSENGER DOOR CONTROL MODULE**

Pin	Description	Active	Inactive
I DP10-1	BATTERY POWER SUPPLY	B+	
O DP10-2	PASSENGER DOOR MIRROR VERTICAL / HORIZONTAL MOVEMENT MOTORS COMMON	B+ = LEFT / DOWN	B+
O DP10-3	PASSENGER DOOR MIRROR HORIZONTAL MOVEMENT MOTOR	B+ = RIGHT	GROUND = RIGHT / UP
O DP10-4	PASSENGER DOOR MIRROR VERTICAL MOVEMENT MOTOR	B+ = UP	GROUND
I DP10-8	LOGIC GROUND	GROUND	GROUND
S DP10-9	SCP NETWORK	2 - 1600 Hz	
S DP10-16	SCP NETWORK	2 - 1600 Hz	
I DP10-17	POWER GROUND	GROUND	GROUND
O DP10-20	PASSENGER DOOR MIRROR POTENTIOMETER COMMON REFERENCE VOLTAGE	B+	
I DP10-21	PASSENGER DOOR MIRROR POTENTIOMETER HORIZONTAL POSITION FEEDBACK VOLTAGE	1 V = LEFT; 8 V = RIGHT	
I DP10-22	PASSENGER DOOR MIRROR POTENTIOMETER VERTICAL POSITION FEEDBACK VOLTAGE	1 V = DOWN; 8 V = UP	

**NOTE:** Refer to the Appendix at the rear of this book for CAN and SCP Network Messages.

The following abbreviations are used to represent values for Control Module Pin-Out data

I	Input	D	Serial and Encoded Data	B+	Battery Voltage	kHz	Frequency x 1000
O	Output	C	CAN (Network)	V	Voltage (DC)	ms	Milliseconds
SG	Signal Ground	S	SCP Network	Hz	Frequency	mV	Millivolts

**CAUTION:** The information on this data page is furnished to aid the user in understanding circuit operation. THIS INFORMATION SHOULD BE USED FOR REFERENCE ONLY.

**NOTE:** The values listed are approximately those that can be expected at the control module connector pins with all circuit connections made and all components connected and fitted. "Active" means a load is applied or a switch is ON; "Inactive" means a load is not applied or a switch is OFF.

**COMPONENTS**

Component	Connector / Type / Color	Location / Access
BODY PROCESSOR MODULE	FC14 / 104-WAY AMP EEEEC / GREY	PASSENGER SIDE FASCIA / AIRBAG BRACKET
DOOR CONTROL MODULE - DRIVER	DD10 / 22-WAY FORD 2.8 TIMER / BLUE DD11 / 22-WAY FORD 2.8 TIMER / BLACK	DRIVER DOOR / DOOR CASING
DOOR CONTROL MODULE - PASSENGER	DP10 / 22-WAY FORD 2.8 TIMER / BLUE DP11 / 22-WAY FORD 2.8 TIMER / BLACK	PASSENGER DOOR / DOOR CASING
DOOR MIRROR MOTORS - DRIVER	DD8 / 12-WAY MULTILOCK 040 / BLACK	DRIVER DOOR
DOOR MIRROR MOTORS - PASSENGER	DP8 / 12-WAY MULTILOCK 040 / BLACK	PASSENGER DOOR
DOOR SWITCH - DRIVER	DD3 / 13-WAY ECONOSEAL III LC / BLACK	DRIVER DOOR / DOOR CASING
MAJOR INSTRUMENT PACK	FC25 / 26-WAY AMP MICRO QUAD LOCK / BLACK FC26 / 26-WAY AMP MICRO QUAD LOCK / YELLOW	FASCIA
MIRROR JOYSTICK (DRIVER DOOR SWITCH PACK)	DD17 / 20-WAY MULTILOCK 040 / BLACK	DRIVER DOOR SWITCH PACK
NOT-IN-PARK MICROSWITCH	FC87 / 3-WAY MULTILOCK 070 / WHITE	GEAR SELECTOR ASSEMBLY
SWITCH PACK - DRIVER DOOR MEMORY	DD5 / 10-WAY AMP MQL / BLACK	DRIVER DOOR

**HARNESS-TO-HARNESS CONNECTORS**

Connector	Type / Color	Location / Access
AC14	14-WAY MULTILOCK 070 / GREY	FASCIA BOTTOM CONNECTOR MOUNTING BRACKET / RIGHT HAND SIDE
DD1	23-WAY AMP - FORD / BLACK	DRIVER SIDE 'A' POST MOUNTING BRACKET / 'A' POST TRIM
DP1	23-WAY AMP - FORD / BLACK	PASSENGER SIDE 'A' POST / 'A' POST TRIM

**GROUNDS**

Ground	Location / Type
FC2AR	EYELET (PAIR) - RIGHT HAND LEG / RIGHT HAND 'A' POST
FC3AS	EYELET (SINGLE) / TRANSMISSION TUNNEL, LEFT HAND SIDE
FC3BR	EYELET (PAIR) - RIGHT HAND LEG / TRANSMISSION TUNNEL, LEFT HAND SIDE
FC4AR	EYELET (PAIR) - RIGHT HAND LEG / LEFT HAND 'A' POST

**FOR CONTROL MODULE PIN OUT INFORMATION, UNFOLD PAGE TO LEFT.**

Refer to the front of this book for detailed information and illustrations regarding the location and identification of harnesses, relays, grounds, control modules and control module pins.



## CONTROL MODULE PIN OUT INFORMATION

### BODY PROCESSOR MODULE

Pin	Description	Active	Inactive
I FC14-15	IGNITION SWITCHED GROUND SUPPLY	GROUND	
I FC14-16	SIDE LAMP REQUEST	GROUND	B+
I FC14-42	DIPPED BEAM REQUEST	GROUND	B+
I FC14-79	BATTERY POWER SUPPLY	B+	B+
I FC14-80	BATTERY POWER SUPPLY (LOGIC)	B+	B+
S FC14-84	SCP NETWORK	2 - 1600 Hz	
S FC14-85	SCP NETWORK	2 - 1600 Hz	

### DRIVER DOOR CONTROL MODULE

Pin	Description	Active	Inactive
I DD10-1	BATTERY POWER SUPPLY	B+	
I DD10-8	LOGIC GROUND	GROUND	B+
S DD10-9	SCP NETWORK	2 - 1600 Hz	
S DD10-16	SCP NETWORK	2 - 1600 Hz	
I DD11-15	DOOR MIRROR POWER FOLD BACK REQUEST	B+	GROUND

### DRIVER SEAT CONTROL MODULE

Pin	Description	Active	Inactive
O SD3-4	DOOR MIRROR FOLD BACK ACTIVATE	GROUND	B+
I SD5-2	POWER GROUND	GROUND	GROUND
I SD5-5	BATTERY POWER SUPPLY	B+	B+
S SD5-9	SCP NETWORK	2 - 1600 Hz	
S SD5-10	SCP NETWORK	2 - 1600 Hz	

### MAJOR INSTRUMENT PACK

Pin	Description	Active	Inactive
C FC25-11	CAN NETWORK	15 - 1500 Hz	
S FC25-13	SCP NETWORK	2 - 1600 Hz	
S FC25-14	SCP NETWORK	2 - 1600 Hz	
C FC25-23	CAN NETWORK	15 - 1500 Hz	

### PASSENGER SEAT CONTROL MODULE

Pin	Description	Active	Inactive
O SP3-4	DOOR MIRROR FOLD OUT ACTIVATE	GROUND	B+
I SP5-2	POWER GROUND	GROUND	GROUND
I SP5-5	BATTERY POWER SUPPLY	B+	B+
S SP5-9	SCP NETWORK	2 - 1600 Hz	
S SP5-10	SCP NETWORK	2 - 1600 Hz	

### SECURITY AND LOCKING CONTROL MODULE

Pin	Description	Active	Inactive
O BT40-5	REVERSE LAMP SUPPLY	B+	
I BT40-6	BATTERY POWER SUPPLY	B+	B+
S BT40-8	SCP NETWORK	2 - 1600 Hz	
I BT40-13	GROUND	GROUND	GROUND
I BT40-14	GROUND	GROUND	GROUND
S BT40-16	SCP NETWORK	2 - 1600 Hz	

NOTE: Refer to the Appendix at the rear of this book for CAN and SCP Network Messages.

Fig. 11.3

### COMPONENTS

Component	Connector / Type / Color	Location / Access
BODY PROCESSOR MODULE	FC14 / 104-WAY AMP EEEEC / GREY	PASSENGER SIDE FASCIA / AIRBAG BRACKET
DOOR CONTROL MODULE - DRIVER	DD10 / 22-WAY FORD 2.8 TIMER / BLUE DD11 / 22-WAY FORD 2.8 TIMER / BLACK	DRIVER DOOR / DOOR CASING
DOOR MIRROR - DRIVER	DD8 / 12-WAY MULTILOCK 040 / BLACK	DRIVER DOOR
DOOR MIRROR - PASSENGER	DP8 / 12-WAY MULTILOCK 040 / BLACK	PASSENGER DOOR
INTERIOR REAR VIEW MIRROR	RF2 / 6-WAY MULTILOCK 070 / YELLOW	WINDSHIELD / FORWARD OF ROOF CONSOLE
LIGHTING STALK (COLUMN SWITCHGEAR)	SC2 / 10-WAY MULTILOCK 070 / YELLOW	STEERING COLUMN
MAJOR INSTRUMENT PACK	FC25 / 26-WAY AMP MICRO QUAD LOCK / BLACK FC26 / 26-WAY AMP MICRO QUAD LOCK / YELLOW	FASCIA
MIRROR JOY STICK (DRIVER DOOR SWITCH PACK)	DD17 / 20-WAY MULTILOCK 040 / BLACK	DRIVER DOOR SWITCH PACK
SEAT CONTROL MODULE - DRIVER	SD3 / 16-WAY FORD 2.8 TIMER / BLACK SD4 / 26-WAY FORD IDC / BLACK SD5 / 10-WAY FORD 2.8 TIMER / BLACK	BELOW SEAT CUSHION
SEAT CONTROL MODULE - PASSENGER	SP3 / 16-WAY FORD 2.8 TIMER / BLACK SP5 / 10-WAY FORD 2.8 TIMER / BLACK	BELOW SEAT CUSHION
SECURITY AND LOCKING CONTROL MODULE	BT40 / 16-WAY FORD 2.8 TIMER / BLACK BT41 / 26-WAY FORD IDC / BLACK RH20 / COAXIAL CONNECTOR	TRUNK / ELECTRICAL CARRIER

### HARNESS-TO-HARNESS CONNECTORS

Connector	Type / Color	Location / Access
AC13	20-WAY MULTILOCK 070 / YELLOW	FASCIA BOTTOM CONNECTOR MOUNTING BRACKET / RIGHT HAND SIDE
AC14	14-WAY MULTILOCK 070 / GREY	FASCIA BOTTOM CONNECTOR MOUNTING BRACKET / RIGHT HAND SIDE
AC16	6-WAY MULTILOCK 070 / YELLOW	LEFT HAND 'A' POST CONNECTOR MOUNTING BRACKET / 'A' POST TRIM
BT1	20-WAY MULTILOCK 070 / WHITE	TRUNK / ABOVE RIGHT HAND REAR WHEEL ARCH
DD1	23-WAY AMP - FORD / BLACK	DRIVER SIDE 'A' POST MOUNTING BRACKET / 'A' POST TRIM
DP1	23-WAY AMP - FORD / BLACK	PASSENGER SIDE 'A' POST / 'A' POST TRIM
RF1	18-WAY MULTILOCK 070 / YELLOW	RIGHT HAND 'A' POST CONNECTOR MOUNTING BRACKET / 'A' POST TRIM
RH12	18-WAY MULTILOCK 070 / YELLOW	REAR OF CENTER CONSOLE ASSEMBLY
RH2	20-WAY MULTILOCK 070 / WHITE	REAR OF CENTER CONSOLE ASSEMBLY
SD1	8-WAY MULTILOCK 070 / YELLOW	BELOW DRIVER SEAT
SP1	8-WAY MULTILOCK 070 / YELLOW	BELOW PASSENGER SEAT

### GROUNDINGS

Ground	Location / Type
BT1AR	EYELET (PAIR) - RIGHT HAND LEG / ADJACENT TO BATTERY
FC2AR	EYELET (PAIR) - RIGHT HAND LEG / RIGHT HAND 'A' POST
FC3BL	EYELET (PAIR) - LEFT HAND LEG / TRANSMISSION TUNNEL, LEFT HAND SIDE
FC3BR	EYELET (PAIR) - RIGHT HAND LEG / TRANSMISSION TUNNEL, LEFT HAND SIDE
FC4AR	EYELET (PAIR) - RIGHT HAND LEG / LEFT HAND 'A' POST
FC5L	EYELET (PAIR) - LEFT HAND LEG / RIGHT HAND SEAT
FC5S	EYELET (SINGLE) / RIGHT HAND SEAT
FC6L	EYELET (PAIR) - LEFT HAND LEG / LEFT HAND SEAT
FC6S	EYELET (SINGLE) / LEFT HAND SEAT

FOR CONTROL MODULE PIN OUT INFORMATION, UNFOLD PAGE TO LEFT.

The following abbreviations are used to represent values for Control Module Pin-Out data

I	Input	D	Serial and Encoded Data	B+	Battery Voltage	kHz	Frequency x 1000
O	Output	C	CAN (Network)	V	Voltage (DC)	ms	Milliseconds
SG	Signal Ground	S	SCP Network	Hz	Frequency	mV	Millivolts

CAUTION: The information on this data page is furnished to aid the user in understanding circuit operation. THIS INFORMATION SHOULD BE USED FOR REFERENCE ONLY.

NOTE: The values listed are approximately those that can be expected at the control module connector pins with all circuit connections made and all components connected and fitted. "Active" means a load is applied or a switch is ON; "Inactive" means a load is not applied or a switch is OFF.

Refer to the front of this book for detailed information and illustrations regarding the location and identification of harnesses, relays, grounds, control modules and control module pins.

## CONTROL MODULE PIN OUT INFORMATION

### BODY PROCESSOR MODULE

Pin	Description	Active	Inactive
I	FC14-15	IGNITION SWITCHED GROUND SUPPLY	GROUND
O	FC14-17	LHD RH (RHD LH) SEAT HEATER STATE LED	GROUND (LED ON)
I	FC14-32	IGNITION SWITCHED GROUND SUPPLY	GROUND
I	FC14-35	LHD RH (RHD LH) SEAT HEATER REQUEST	GROUND
I	FC14-41	IGNITION GROUND SUPPLY	GROUND
O	FC14-69	LHD LH SEAT HEATER STATUS LED (RHD = RH)	GROUND
I	FC14-80	BATTERY POWER SUPPLY (LOGIC)	B+
S	FC14-84	SCP NETWORK	2 - 1600 Hz
S	FC14-85	SCP NETWORK	2 - 1600 Hz
I	FC14-86	LHD LH (RHD RH) SEAT HEATER REQUEST	GROUND (MOMENTARY)

### DRIVER DOOR CONTROL MODULE

Pin	Description	Active	Inactive
I	DD10-1	BATTERY POWER SUPPLY	B+
I	DD10-8	LOGIC GROUND	GROUND
S	DD10-9	SCP NETWORK	2 - 1600 Hz
S	DD10-16	SCP NETWORK	2 - 1600 Hz
I	DD10-17	POWER GROUND	GROUND
O	DD11-2	SEAT MEMORY STATUS LED	GROUND (LED ON)
I	DD11-6	MEMORY SET REQUEST	B+
I	DD11-21	MEMORY 1 RECALL REQUEST	B+ (MOMENTARY)
I	DD11-22	MEMORY 2 RECALL REQUEST	B+ (MOMENTARY)

### DRIVER SEAT CONTROL MODULE

Pin	Description	Active	Inactive
O	SD3-1	DRIVER SEAT SQUAB MOTOR SUPPLY - FORWARD	GROUND
O	SD3-2	DRIVER SEAT SQUAB MOTOR SUPPLY - REAR	GROUND
O	SD3-3	DRIVER SEAT HEATER ELEMENTS SUPPLY	GROUND
O	SD3-5	DRIVER SEAT LUMBAR PUMP INFLATE MOTOR	GROUND
O	SD3-6	DRIVER SEAT LUMBAR PUMP DEFLATE SOLENOID	GROUND
O	SD3-7	DRIVER SEAT FORE / AFT MOTOR SUPPLY	GROUND
O	SD3-8	DRIVER SEAT FORE / AFT MOTOR SUPPLY	GROUND
I	SD3-9	DRIVER SEAT FORE MOVEMENT REQUEST	B+ (MOMENTARY)
I	SD3-10	DRIVER SEAT AFT MOVEMENT REQUEST	B+ (MOMENTARY)
I	SD3-11	DRIVER SEAT CUSHION REAR EDGE LOWER REQUEST	B+ (MOMENTARY)
I	SD3-12	DRIVER SEAT CUSHION REAR EDGE RAISE REQUEST	B+ (MOMENTARY)
I	SD3-13	DRIVER SEAT LUMBAR INFLATE REQUEST	B+ (MOMENTARY)
I	SD3-14	DRIVER SEAT LUMBAR DEFLATE REQUEST	B+ (MOMENTARY)
I	SD3-15	DRIVER SEAT SQUAB AFT RECLINE REQUEST	B+ (MOMENTARY)
I	SD3-16	DRIVER SEAT SQUAB FORE RECLINE REQUEST	B+ (MOMENTARY)
O	SD4-1	DRIVER SEAT SQUAB POTENTIOMETER REFERENCE GROUND	GROUND
O	SD4-2	DRIVER SEAT FORE / AFT MOVEMENT POTENTIOMETER REFERENCE GROUND	GROUND
O	SD4-5	DRIVER SEAT SQUAB POT. REFERENCE VOLTAGE	B+
O	SD4-6	DRIVER SEAT RAISE / LOWER POTENTIOMETER REFERENCE VOLTAGE	B+
I	SD4-10	DRIVER SEAT RAISE / LOWER POTENTIOMETER FEEDBACK	10 V = UP; 2 V = DOWN
I	SD4-11	DRIVER SEAT SQUAB POT. FEEDBACK	9 V = UP; 4 V = DOWN
I	SD4-12	DRIVER SEAT FORE / AFT POTENTIOMETER FEEDBACK	10 V = FORWARD; 2 V = REAR
O	SD4-14	DRIVER SEAT RAISE / LOWER POTENTIOMETER REFERENCE GROUND	GROUND
O	SD4-18	DRIVER SEAT FORE / AFT MOVEMENT POTENTIOMETER REFERENCE VOLTAGE	B+
I	SD5-1	DRIVER OR PASSENGER SEAT IDENTIFICATION	GROUND (DRIVER)
I	SD5-2	POWER GROUND	GROUND
O	SD5-3	DRIVER SEAT RAISE / LOWER MOTOR SUPPLY	B+
O	SD5-4	DRIVER SEAT RAISE / LOWER MOTOR SUPPLY	B+
I	SD5-5	BATTERY POWER SUPPLY	B+
I	SD5-8	DRIVER SEAT BELT FASTENED	B+ (FASTENED)
S	SD5-9	SCP NETWORK	2 - 1600 Hz
S	SD5-10	SCP NETWORK	2 - 1600 Hz

### MAJOR INSTRUMENT PACK

Pin	Description	Active	Inactive
C	FC25-11	CAN NETWORK	15 - 1500 Hz
S	FC25-13	SCP NETWORK	2 - 1600 Hz
S	FC25-14	SCP NETWORK	2 - 1600 Hz
C	FC25-23	CAN NETWORK	15 - 1500 Hz

NOTE: Refer to the Appendix at the rear of this book for CAN and SCP Network Messages.

The following abbreviations are used to represent values for Control Module Pin-Out data

I	Input	D	Serial and Encoded Data	B+	Battery Voltage	kHz	Frequency x 1000
O	Output	C	CAN (Network)	V	Voltage (DC)	ms	Milliseconds
SG	Signal Ground	S	SCP Network	Hz	Frequency	mV	Millivolts

CAUTION: The information on this data page is furnished to aid the user in understanding circuit operation. THIS INFORMATION SHOULD BE USED FOR REFERENCE ONLY.

NOTE: The values listed are approximately those that can be expected at the control module connector pins with all circuit connections made and all components connected and fitted. "Active" means a load is applied or a switch is ON; "Inactive" means a load is not applied or a switch is OFF.

Fig. 12.1

### COMPONENTS

Component	Connector / Type / Color	Location / Access
BODY PROCESSOR MODULE	FC14 / 104-WAY AMP EEEEC / GREY	PASSENGER SIDE FASCIA / AIRBAG BRACKET
DOOR CONTROL MODULE - DRIVER	DD10 / 22-WAY FORD 2.8 TIMER / BLUE DD11 / 22-WAY FORD 2.8 TIMER / BLACK	DRIVER DOOR / DOOR CASING
MAJOR INSTRUMENT PACK	FC25 / 26-WAY AMP MICRO QUAD LOCK / BLACK FC26 / 26-WAY AMP MICRO QUAD LOCK / YELLOW	FASCIA
SEAT BELT SWITCH	SD20 / 2-WAY MULTILOCK 040 / BLACK	BELOW SEAT CUSHION
SEAT CONTROL MODULE - DRIVER	SD3 / 16-WAY FORD 2.8 TIMER / BLACK SD4 / 26-WAY FORD IDC / BLACK SD5 / 10-WAY FORD 2.8 TIMER / BLACK	BELOW SEAT CUSHION
SEAT CUSHION (HEATER) - DRIVER	SD19 / 3-WAY MULTILOCK 070 / YELLOW	SEAT CUSHION
SEAT HEATER SWITCH (CENTER CONSOLE SWITCH PACK)	FC55 / 20-WAY FORD IDC / BLACK	CENTER CONSOLE SWITCH PACK
SEAT LUMBAR PUMP - DRIVER	SD14 / 3-WAY MULTILOCK 070 / YELLOW	SEAT BACK
SEAT MOTORS - DRIVER	SD7 / 6-WAY MULTILOCK 070 / WHITE SD8 / 6-WAY MULTILOCK 070 / WHITE SD9 / 6-WAY MULTILOCK 070 / YELLOW	BELOW SEAT CUSHION
SQUAB (HEATER) - DRIVER	SD17 / 3-WAY MULTILOCK 070 / GREY	SEAT SQUAB
SWITCH PACK - DRIVER DOOR MEMORY	DD5 / 10-WAY AMP MQL / BLACK	DRIVER DOOR
SWITCH PACK - DRIVER SEAT	SD11 / 16-WAY MULTILOCK 040 / BLACK	DRIVER SEAT

### HARNESSTO-HARNESSTO CONNECTORS

Connector	Type / Color	Location / Access
AC14	14-WAY MULTILOCK 070 / GREY	FASCIA BOTTOM CONNECTOR MOUNTING BRACKET / RIGHT HAND SIDE
DD1	23-WAY AMP - FORD / BLACK	DRIVER SIDE 'A' POST MOUNTING BRACKET / 'A' POST TRIM
SD1	8-WAY MULTILOCK 070 / YELLOW	BELOW DRIVER SEAT

### GROUNDS

Ground	Location / Type
FC2AR	EYELET (PAIR) - RIGHT HAND LEG / RIGHT HAND 'A' POST
FC2BR	EYELET (PAIR) - RIGHT HAND LEG / RIGHT HAND 'A' POST
FC4AR	EYELET (PAIR) - RIGHT HAND LEG / LEFT HAND 'A' POST
FC4BR	EYELET (PAIR) - RIGHT HAND LEG / LEFT HAND 'A' POST
FC5L	EYELET (PAIR) - LEFT HAND LEG / RIGHT HAND SEAT
FC5R	EYELET (PAIR) - RIGHT HAND LEG / RIGHT HAND SEAT
FC6L	EYELET (PAIR) - LEFT HAND LEG / LEFT HAND SEAT
FC6R	EYELET (PAIR) - RIGHT HAND LEG / LEFT HAND SEAT

FOR CONTROL MODULE PIN OUT INFORMATION, UNFOLD PAGE TO LEFT.

Refer to the front of this book for detailed information and illustrations regarding the location and identification of harnesses, relays, grounds, control modules and control module pins.

**CONTROL MODULE PIN OUT INFORMATION**

**Fig. 12.2**

**BODY PROCESSOR MODULE**

Pin	Description	Active	Inactive
I FC14-15	IGNITION SWITCHED GROUND SUPPLY	GROUND	
O FC14-17	LHD RH (RHD LH) SEAT HEATER STATE LED	GROUND (LED ON)	B+
I FC14-32	IGNITION SWITCHED GROUND SUPPLY	GROUND	GROUND
I FC14-35	LHD RH (RHD LH) SEAT HEATER REQUEST	GROUND	B+
O FC14-69	LHD LH SEAT HEATER STATUS LED (RHD = RH)	GROUND	B+
I FC14-80	BATTERY POWER SUPPLY (LOGIC)	B+	B+
S FC14-84	SCP NETWORK	2 - 1600 Hz	
S FC14-85	SCP NETWORK	2 - 1600 Hz	
I FC14-86	LHD LH (RHD RH) SEAT HEATER REQUEST	GROUND (MOMENTARY)	B+

**DRIVER SEAT CONTROL MODULE**

Pin	Description	Active	Inactive
O SD3-1	DRIVER SEAT SQUAB MOTOR SUPPLY - FORWARD	B+	GROUND
O SD3-2	DRIVER SEAT SQUAB MOTOR SUPPLY - REAR	B+	GROUND
O SD3-3	DRIVER SEAT HEATER ELEMENTS SUPPLY	B+	GROUND
O SD3-5	DRIVER SEAT LUMBAR PUMP INFLATE MOTOR	B+	GROUND
O SD3-6	DRIVER SEAT LUMBAR PUMP DEFLATE SOLENOID	B+	GROUND
O SD3-7	DRIVER SEAT FORE / AFT MOTOR SUPPLY	B+	GROUND
O SD3-8	DRIVER SEAT FORE / AFT MOTOR SUPPLY	B+	GROUND
I SD3-9	DRIVER SEAT FORE MOVEMENT REQUEST	B+ (MOMENTARY)	GROUND
I SD3-10	DRIVER SEAT AFT MOVEMENT REQUEST	B+ (MOMENTARY)	GROUND
I SD3-11	DRIVER SEAT CUSHION REAR EDGE LOWER REQUEST	B+ (MOMENTARY)	GROUND
I SD3-12	DRIVER SEAT CUSHION REAR EDGE RAISE REQUEST	B+ (MOMENTARY)	GROUND
I SD3-13	DRIVER SEAT LUMBAR INFLATE REQUEST	B+ (MOMENTARY)	GROUND
I SD3-14	DRIVER SEAT LUMBAR DEFLATE REQUEST	B+ (MOMENTARY)	GROUND
I SD3-15	DRIVER SEAT SQUAB AFT RECLINE REQUEST	B+ (MOMENTARY)	GROUND
I SD3-16	DRIVER SEAT SQUAB FORE RECLINE REQUEST	B+ (MOMENTARY)	GROUND
I SD5-1	DRIVER OR PASSENGER SEAT IDENTIFICATION	GROUND (DRIVER)	
I SD5-2	POWER GROUND	GROUND	GROUND
O SD5-3	DRIVER SEAT RAISE / LOWER MOTOR SUPPLY	B+	GROUND
O SD5-4	DRIVER SEAT RAISE / LOWER MOTOR SUPPLY	B+	GROUND
I SD5-5	BATTERY POWER SUPPLY	B+	B+
I SD5-8	DRIVER SEAT BELT FASTENED	B+ (FASTENED)	GROUND
S SD5-9	SCP NETWORK	2 - 1600 Hz	
S SD5-10	SCP NETWORK	2 - 1600 Hz	

**NOTE:** Refer to the Appendix at the rear of this book for CAN and SCP Network Messages.

**COMPONENTS**

Component	Connector / Type / Color	Location / Access
BODY PROCESSOR MODULE	FC14 / 104-WAY AMP EEEEC / GREY	PASSENGER SIDE FASCIA / AIRBAG BRACKET
SEAT BELT SWITCH	SD20 / 2-WAY MULTILOCK 040 / BLACK	BELOW SEAT CUSHION
SEAT CONTROL MODULE - DRIVER	SD3 / 16-WAY FORD 2.8 TIMER / BLACK SD4 / 26-WAY FORD IDC / BLACK SD5 / 10-WAY FORD 2.8 TIMER / BLACK	BELOW SEAT CUSHION
SEAT CUSHION (HEATER) - DRIVER	SD19 / 3-WAY MULTILOCK 070 / YELLOW	SEAT CUSHION
SEAT HEATER SWITCH (CENTER CONSOLE SWITCH PACK)	FC55 / 20-WAY FORD IDC / BLACK	CENTER CONSOLE SWITCH PACK
SEAT LUMBAR PUMP - DRIVER	SD14 / 3-WAY MULTILOCK 070 / YELLOW	SEAT BACK
SEAT MOTORS - DRIVER	SD7 / 6-WAY MULTILOCK 070 / WHITE SD8 / 6-WAY MULTILOCK 070 / WHITE SD9 / 6-WAY MULTILOCK 070 / YELLOW	BELOW SEAT CUSHION
SQUAB (HEATER) - DRIVER	SD17 / 3-WAY MULTILOCK 070 / GREY	SEAT SQUAB
SWITCH PACK - DRIVER SEAT	SD11 / 16-WAY MULTILOCK 040 / BLACK	DRIVER SEAT

**HARNESSTO-HARNESSTO CONNECTORS**

Connector	Type / Color	Location / Access
SD1	8-WAY MULTILOCK 070 / YELLOW	BELOW DRIVER SEAT

**GROUNDS**

Ground	Location / Type
FC2BR	EYELET (PAIR) - RIGHT HAND LEG / RIGHT HAND 'A' POST
FC4BR	EYELET (PAIR) - RIGHT HAND LEG / LEFT HAND 'A' POST
FC5L	EYELET (PAIR) - LEFT HAND LEG / RIGHT HAND SEAT
FC5R	EYELET (PAIR) - RIGHT HAND LEG / RIGHT HAND SEAT
FC6L	EYELET (PAIR) - LEFT HAND LEG / LEFT HAND SEAT
FC6R	EYELET (PAIR) - RIGHT HAND LEG / LEFT HAND SEAT

**FOR CONTROL MODULE PIN OUT INFORMATION, UNFOLD PAGE TO LEFT.**

The following abbreviations are used to represent values for Control Module Pin-Out data

I	Input	D	Serial and Encoded Data	B+	Battery Voltage	kHz	Frequency x 1000
O	Output	C	CAN (Network)	V	Voltage (DC)	ms	Milliseconds
SG	Signal Ground	S	SCP Network	Hz	Frequency	mV	Millivolts

**CAUTION:** The information on this data page is furnished to aid the user in understanding circuit operation. THIS INFORMATION SHOULD BE USED FOR REFERENCE ONLY.

**NOTE:** The values listed are approximately those that can be expected at the control module connector pins with all circuit connections made and all components connected and fitted. "Active" means a load is applied or a switch is ON; "Inactive" means a load is not applied or a switch is OFF.

Refer to the front of this book for detailed information and illustrations regarding the location and identification of harnesses, relays, grounds, control modules and control module pins.

**CONTROL MODULE PIN OUT INFORMATION**

**BODY PROCESSOR MODULE**

Pin	Description	Active	Inactive
I FC14-15	IGNITION SWITCHED GROUND SUPPLY	GROUND	B+
O FC14-17	LHD RH (RHD LH) SEAT HEATER STATE LED	GROUND (LED ON)	GROUND
I FC14-32	IGNITION SWITCHED GROUND SUPPLY	GROUND	B+
I FC14-35	LHD RH (RHD LH) SEAT HEATER REQUEST	GROUND	B+
O FC14-69	LHD LH SEAT HEATER STATUS LED (RHD = RH)	GROUND	B+
I FC14-80	BATTERY POWER SUPPLY (LOGIC)	B+	B+
S FC14-84	SCP NETWORK	2 - 1600 Hz	
S FC14-85	SCP NETWORK	2 - 1600 Hz	
I FC14-86	LHD LH (RHD RH) SEAT HEATER REQUEST	GROUND (MOMENTARY)	B+

**PASSENGER SEAT CONTROL MODULE**

Pin	Description	Active	Inactive
O SP3-1	PASSENGER SEAT SQUAB MOTOR SUPPLY - FORWARD	B+	GROUND
O SP3-2	PASSENGER SEAT SQUAB MOTOR SUPPLY - REAR	B+	GROUND
O SP3-3	PASSENGER SEAT HEATER ELEMENTS SUPPLY	B+	GROUND
O SP3-5	PASSENGER SEAT LUMBAR PUMP INFLATE MOTOR	B+	GROUND
O SP3-6	PASSENGER SEAT LUMBAR PUMP DEFLATE SOLENOID	B+	GROUND
O SP3-7	PASSENGER SEAT FORE / AFT MOTOR SUPPLY - FORWARD	B+	GROUND
O SP3-8	PASSENGER SEAT FORE / AFT MOTOR SUPPLY - REAR	B+	GROUND
I SP3-9	PASSENGER SEAT FORE MOVEMENT REQUEST	B+ (MOMENTARY)	GROUND
I SP3-10	PASSENGER SEAT AFT MOVEMENT REQUEST	B+ (MOMENTARY)	GROUND
I SP3-11	PASSENGER SEAT CUSHION REAR EDGE LOWER REQUEST	B+ (MOMENTARY)	GROUND
I SP3-12	PASSENGER SEAT CUSHION REAR EDGE RAISE REQUEST	B+ (MOMENTARY)	GROUND
I SP3-13	PASSENGER SEAT LUMBAR INFLATE REQUEST	B+ (MOMENTARY)	GROUND
I SP3-14	PASSENGER SEAT LUMBAR DEFLATE REQUEST	B+ (MOMENTARY)	GROUND
I SP3-15	PASSENGER SEAT SQUAB AFT RECLINE REQUEST	B+ (MOMENTARY)	GROUND
I SP3-16	PASSENGER SEAT SQUAB FORE RECLINE REQUEST	B+ (MOMENTARY)	GROUND
I SP5-1	DRIVER OR PASSENGER SEAT IDENTIFICATION	GROUND (DRIVER)	GROUND (PASSENGER)
I SP5-2	POWER GROUND	GROUND	GROUND
O SP5-3	PASSENGER SEAT RAISE / LOWER MOTOR SUPPLY	NOT USED	
O SP5-4	PASSENGER SEAT RAISE / LOWER MOTOR SUPPLY	NOT USED	
I SP5-5	BATTERY POWER SUPPLY	B+	B+
I SP5-8	NOT USED		
S SP5-9	SCP NETWORK	2 - 1600 Hz	
S SP5-10	SCP NETWORK	2 - 1600 Hz	

**NOTE:** Refer to the Appendix at the rear of this book for CAN and SCP Network Messages.

**Fig. 12.3**

**COMPONENTS**

Component	Connector / Type / Color	Location / Access
BODY PROCESSOR MODULE	FC14 / 104-WAY AMP EEEEC / GREY	PASSENGER SIDE FASCIA / AIRBAG BRACKET
SEAT BELT SWITCH	SP20 / 2-WAY MULTILOCK 040 / BLACK	BELOW SEAT CUSHION
SEAT CONTROL MODULE - PASSENGER	SP3 / 16-WAY FORD 2.8 TIMER / BLACK SP5 / 10-WAY FORD 2.8 TIMER / BLACK	BELOW SEAT CUSHION
SEAT CUSHION (HEATER) - PASSENGER	SP19 / 3-WAY MULTILOCK 070 / YELLOW	SEAT CUSHION
SEAT HEATER SWITCH (CENTER CONSOLE SWITCH PACK)	FC55 / 20-WAY FORD IDC / BLACK	CENTER CONSOLE SWITCH PACK
SEAT LUMBAR PUMP - PASSENGER	SP14 / 3-WAY MULTILOCK 070 / YELLOW	SEAT BACK
SEAT MOTORS - PASSENGER	SP7 / 6-WAY MULTILOCK 070 / WHITE SP8 / 6-WAY MULTILOCK 070 / WHITE SP9 / 6-WAY MULTILOCK 070 / YELLOW	BELOW SEAT CUSHION
SQUAB (HEATER) - PASSENGER	SP17 / 3-WAY MULTILOCK 070 / GREY	SEAT SQUAB
SWITCH PACK - PASSENGER SEAT	SP11 / 16-WAY MULTILOCK 040 / BLACK	PASSENGER SEAT

**HARNESS-TO-HARNESS CONNECTORS**

Connector	Type / Color	Location / Access
SP1	8-WAY MULTILOCK 070 / YELLOW	BELOW PASSENGER SEAT

**GROUNDS**

Ground	Location / Type
FC2BR	EYELET (PAIR) - RIGHT HAND LEG / RIGHT HAND 'A' POST
FC4BR	EYELET (PAIR) - RIGHT HAND LEG / LEFT HAND 'A' POST
FC5S	EYELET (SINGLE) / RIGHT HAND SEAT
FC6S	EYELET (SINGLE) / LEFT HAND SEAT

**FOR CONTROL MODULE PIN OUT INFORMATION, UNFOLD PAGE TO LEFT.**

The following abbreviations are used to represent values for Control Module Pin-Out data

I	Input	D	Serial and Encoded Data	B+	Battery Voltage	kHz	Frequency x 1000
O	Output	C	CAN (Network)	V	Voltage (DC)	ms	Milliseconds
SG	Signal Ground	S	SCP Network	Hz	Frequency	mV	Millivolts

**CAUTION:** The information on this data page is furnished to aid the user in understanding circuit operation. THIS INFORMATION SHOULD BE USED FOR REFERENCE ONLY.

**NOTE:** The values listed are approximately those that can be expected at the control module connector pins with all circuit connections made and all components connected and fitted. "Active" means a load is applied or a switch is ON; "Inactive" means a load is not applied or a switch is OFF.

Refer to the front of this book for detailed information and illustrations regarding the location and identification of harnesses, relays, grounds, control modules and control module pins.

**CONTROL MODULE PIN OUT INFORMATION**

**BODY PROCESSOR MODULE**

Pin	Description	Active	Inactive
I	FC14-15	IGNITION SWITCHED GROUND SUPPLY	GROUND
O	FC14-17	LHD RH (RHD LH) SEAT HEATER STATE LED	GROUND (LED ON)
I	FC14-32	IGNITION SWITCHED GROUND SUPPLY	GROUND
I	FC14-35	LHD RH (RHD LH) SEAT HEATER REQUEST	GROUND
O	FC14-69	LHD LH SEAT HEATER STATUS LED (RHD = RH)	GROUND
I	FC14-80	BATTERY POWER SUPPLY (LOGIC)	B+
S	FC14-84	SCP NETWORK	2 - 1600 Hz
S	FC14-85	SCP NETWORK	2 - 1600 Hz
I	FC14-86	LHD LH (RHD RH) SEAT HEATER REQUEST	GROUND (MOMENTARY)

**PASSENGER SEAT CONTROL MODULE**

Pin	Description	Active	Inactive
O	SP3-1	PASSENGER SEAT SQUAB MOTOR SUPPLY - FORWARD	B+
O	SP3-2	PASSENGER SEAT SQUAB MOTOR SUPPLY - REAR	B+
O	SP3-3	PASSENGER SEAT HEATER ELEMENTS SUPPLY	B+
O	SP3-5	PASSENGER SEAT LUMBAR PUMP INFLATE MOTOR	B+
O	SP3-6	PASSENGER SEAT LUMBAR PUMP DEFLATE SOLENOID	B+
O	SP3-7	PASSENGER SEAT FORE / AFT MOTOR SUPPLY - FORWARD	B+
O	SP3-8	PASSENGER SEAT FORE / AFT MOTOR SUPPLY - REAR	B+
I	SP3-9	PASSENGER SEAT FORE MOVEMENT REQUEST	B+ (MOMENTARY)
I	SP3-10	PASSENGER SEAT AFT MOVEMENT REQUEST	B+ (MOMENTARY)
I	SP3-13	PASSENGER SEAT LUMBAR INFLATE REQUEST	B+ (MOMENTARY)
I	SP3-14	PASSENGER SEAT LUMBAR DEFLATE REQUEST	B+ (MOMENTARY)
I	SP3-15	PASSENGER SEAT SQUAB AFT RECLINE REQUEST	B+ (MOMENTARY)
I	SP3-16	PASSENGER SEAT SQUAB FORE RECLINE REQUEST	B+ (MOMENTARY)
I	SP5-1	DRIVER OR PASSENGER SEAT IDENTIFICATION	GROUND (DRIVER)
I	SP5-2	POWER GROUND	GROUND
I	SP5-5	BATTERY POWER SUPPLY	B+
	SP5-8	NOT USED	
S	SP5-9	SCP NETWORK	2 - 1600 Hz
S	SP5-10	SCP NETWORK	2 - 1600 Hz

**NOTE:** Refer to the Appendix at the rear of this book for CAN and SCP Network Messages.

**Fig. 12.4**

**COMPONENTS**

Component	Connector / Type / Color	Location / Access
BODY PROCESSOR MODULE	FC14 / 104-WAY AMP EEEEC / GREY	PASSENGER SIDE FASCIA / AIRBAG BRACKET
SEAT BELT SWITCH WIRING (NOT USED)	SP20 / 2-WAY MULTILOCK 040 / BLACK	BELOW SEAT CUSHION
SEAT CONTROL MODULE - PASSENGER	SP3 / 16-WAY FORD 2.8 TIMER / BLACK SP5 / 10-WAY FORD 2.8 TIMER / BLACK	BELOW SEAT CUSHION
SEAT CUSHION (HEATER) - PASSENGER	SP19 / 3-WAY MULTILOCK 070 / YELLOW	SEAT CUSHION
SEAT HEATER SWITCH (CENTER CONSOLE SWITCH PACK)	FC55 / 20-WAY FORD IDC / BLACK	CENTER CONSOLE SWITCH PACK
SEAT MOTORS - PASSENGER	SP7 / 6-WAY MULTILOCK 070 / WHITE SP8 / 6-WAY MULTILOCK 070 / WHITE SP9 / 6-WAY MULTILOCK 070 / YELLOW	BELOW SEAT CUSHION
SQUAB (HEATER) - PASSENGER	SP17 / 3-WAY MULTILOCK 070 / GREY	SEAT SQUAB
SWITCH PACK - PASSENGER SEAT	SP11 / 16-WAY MULTILOCK 040 / BLACK	PASSENGER SEAT

**HARNESSTO-HARNESSTO CONNECTORS**

Connector	Type / Color	Location / Access
SP1	8-WAY MULTILOCK 070 / YELLOW	BELOW PASSENGER SEAT

**GROUNDSTO**

Ground	Location / Type
FC2BR	EYELET (PAIR) - RIGHT HAND LEG / RIGHT HAND 'A' POST
FC4BR	EYELET (PAIR) - RIGHT HAND LEG / LEFT HAND 'A' POST
FC5S	EYELET (SINGLE) / RIGHT HAND SEAT
FC6S	EYELET (SINGLE) / LEFT HAND SEAT

**FOR CONTROL MODULE PIN OUT INFORMATION, UNFOLD PAGE TO LEFT.**

The following abbreviations are used to represent values for Control Module Pin-Out data

I	Input	D	Serial and Encoded Data	B+	Battery Voltage	kHz	Frequency x 1000
O	Output	C	CAN (Network)	V	Voltage (DC)	ms	Milliseconds
SG	Signal Ground	S	SCP Network	Hz	Frequency	mV	Millivolts

**CAUTION:** The information on this data page is furnished to aid the user in understanding circuit operation. THIS INFORMATION SHOULD BE USED FOR REFERENCE ONLY.

**NOTE:** The values listed are approximately those that can be expected at the control module connector pins with all circuit connections made and all components connected and fitted. "Active" means a load is applied or a switch is ON; "Inactive" means a load is not applied or a switch is OFF.

Refer to the front of this book for detailed information and illustrations regarding the location and identification of harnesses, relays, grounds, control modules and control module pins.

## CONTROL MODULE PIN OUT INFORMATION

### BODY PROCESSOR MODULE

Pin	Description	Active	Inactive
I FC14-5	TRUNK LATCH RELEASE REQUEST	GROUND (MOMENTARY)	B+
I FC14-15	IGNITION SWITCHED GROUND SUPPLY	GROUND	B+
I FC14-31	FUEL FLAP RELEASE REQUEST	GROUND (MOMENTARY)	GROUND
I FC14-33	IGNITION SWITCHED GROUND SUPPLY	GROUND	GROUND
I FC14-41	IGNITION GROUND SUPPLY	GROUND	B+
I FC14-55	VALET SWITCH	GROUND (MOMENTARY)	B+ (PARK)
I FC14-58	NOT-IN-PARK	GROUND (R,N,D,4,3,2)	B+
I FC14-67	KEY IN IGNITION	GROUND (KEY IN)	B+
O FC14-71	DOOR LOCK RELAY ACTIVATE	GROUND (PULSE)	B+
I FC14-80	BATTERY POWER SUPPLY (LOGIC)	B+	B+
S FC14-84	SCP NETWORK	2 – 1600 Hz	
S FC14-85	SCP NETWORK	2 – 1600 Hz	

### DRIVER DOOR CONTROL MODULE

Pin	Description	Active	Inactive
I DD10-1	BATTERY POWER SUPPLY	B+	B+
O DD10-5	DOOR LOCK ACTUATOR MOTOR UNLOCK	B+	GROUND
O DD10-6	DOOR LOCK ACTUATOR MOTOR LOCK	B+	GROUND
I DD10-8	LOGIC GROUND	GROUND	GROUND
S DD10-9	SCP NETWORK	2 – 1600 Hz	
S DD10-16	SCP NETWORK	2 – 1600 Hz	
I DD10-17	POWER GROUND	GROUND	GROUND
I DD11-4	DRIVER DOOR LOCK BARREL UNLOCK REQUEST	B+ (MOMENTARY)	GROUND
I DD11-5	EXTERIOR DOOR HANDLE WINDOW DROP REQUEST	B+	GROUND
I DD11-12	DRIVER DOOR LOCK BARREL LOCK REQUEST	B+ (MOMENTARY)	GROUND
I DD11-20	DRIVER DOOR SWITCH	GROUND (DOOR OPEN)	B+

### PASSENGER DOOR CONTROL MODULE

Pin	Description	Active	Inactive
I DP10-1	BATTERY POWER SUPPLY	B+	B+
O DP10-5	PASSENGER DOOR LOCK ACTUATOR MOTOR UNLOCK	B+	GROUND
O DP10-6	PASSENGER DOOR LOCK ACTUATOR MOTOR LOCK	B+	GROUND
I DP10-8	LOGIC GROUND	GROUND	GROUND
S DP10-9	SCP NETWORK	2 – 1600 Hz	
S DP10-16	SCP NETWORK	2 – 1600 Hz	
I DP10-17	POWER GROUND	GROUND	GROUND
I DP11-5	EXTERIOR DOOR HANDLE WINDOW DROP REQUEST	B+	GROUND
I DP11-20	PASSENGER DOOR SWITCH	GROUND (DOOR OPEN)	B+

### SECURITY AND LOCKING CONTROL MODULE

Pin	Description	Active	Inactive
O BT40-1	TRUNK RELEASE SOLENOID	B+	GROUND
O BT40-2	FUEL FILLER FLAP SOLENOID	B+	GROUND
S BT40-8	SCP NETWORK	2 – 1600 Hz	
I BT40-13	GROUND	GROUND	GROUND
I BT40-14	GROUND	GROUND	GROUND
I BT40-15	BATTERY POWER SUPPLY	B+	B+
S BT40-16	SCP NETWORK	2 – 1600 Hz	
I BT41-5	TRUNK SWITCH	GROUND	B+
I BT41-7	PASSENGER DOOR LOCK ACTUATOR LOCK STATUS	GROUND (LOCKED)	B+
I BT41-19	DRIVER DOOR LOCK ACTUATOR LOCK STATUS	GROUND (LOCKED)	B+
I RH20-1	KEY FOB ANTENNA		
I RH20-2	KEY FOB ANTENNA SHIELD	GROUND	GROUND

**NOTE:** Refer to the Appendix at the rear of this book for CAN and SCP Network Messages.

The following abbreviations are used to represent values for Control Module Pin-Out data

I	Input	D	Serial and Encoded Data	B+	Battery Voltage	kHz	Frequency x 1000
O	Output	C	CAN (Network)	V	Voltage (DC)	ms	Milliseconds
SG	Signal Ground	S	SCP Network	Hz	Frequency	mV	Millivolts

**CAUTION:** The information on this data page is furnished to aid the user in understanding circuit operation. THIS INFORMATION SHOULD BE USED FOR REFERENCE ONLY.

**NOTE:** The values listed are approximately those that can be expected at the control module connector pins with all circuit connections made and all components connected and fitted. "Active" means a load is applied or a switch is ON; "Inactive" means a load is not applied or a switch is OFF.

**Fig. 13.1**

### COMPONENTS

Component	Connector / Type / Color	Location / Access
BODY PROCESSOR MODULE	FC14 / 104-WAY AMP EEEEC / GREY	PASSENGER SIDE FASCIA / AIRBAG BRACKET
DOOR CONTROL MODULE – DRIVER	DD10 / 22-WAY FORD 2.8 TIMER / BLUE DD11 / 22-WAY FORD 2.8 TIMER / BLACK	DRIVER DOOR / DOOR CASING
DOOR CONTROL MODULE – PASSENGER	DP10 / 22-WAY FORD 2.8 TIMER / BLUE DP11 / 22-WAY FORD 2.8 TIMER / BLACK	PASSENGER DOOR / DOOR CASING
DOOR LOCK ACTUATOR – DRIVER	DD3 / 13-WAY ECONOSEAL III LC / BLACK	DRIVER DOOR / DOOR CASING
DOOR LOCK ACTUATOR – PASSENGER	DP3 / 13-WAY ECONOSEAL III LC / BLACK	PASSENGER DOOR / DOOR CASING
DOOR LOCK SWITCH – PASSENGER	DP3 / 13-WAY ECONOSEAL III LC / BLACK	PASSENGER DOOR / DOOR CASING
DOOR LOCK SWITCHES – DRIVER	DD3 / 13-WAY ECONOSEAL III LC / BLACK	DRIVER DOOR / DOOR CASING
DOOR SWITCH – DRIVER	DD3 / 13-WAY ECONOSEAL III LC / BLACK	DRIVER DOOR / DOOR CASING
DOOR SWITCH – PASSENGER	DP3 / 13-WAY ECONOSEAL III LC / BLACK	PASSENGER DOOR / DOOR CASING
FUEL FILL FLAP SOLENOID	IC24 / 2-WAY LABINAL / NATURAL	TRUNK / FUEL FILL
IGNITION SWITCH (KEY-IN SWITCH)	FC4 / 8-WAY MULTILOCK 070 / WHITE	STEERING COLUMN
KEY FOB ANTENNA (CONVERTIBLE)	HARD WIRED	TOP OF BACKLIGHT
KEY FOB ANTENNA (COUPE)	RH7 / COAXIAL CONNECTOR	TOP OF BACKLIGHT
NOT-IN-PARK MICROSWITCH	FC87 / 3-WAY MULTILOCK 070 / WHITE	GEAR SELECTOR ASSEMBLY
SECURITY AND LOCKING CONTROL MODULE	BT40 / 16-WAY FORD 2.8 TIMER / BLACK BT41 / 26-WAY FORD IDC / BLACK RH20 / COAXIAL CONNECTOR	TRUNK / ELECTRICAL CARRIER
TRUNK AND FUEL FILL RELEASE SWITCH	FC41 / 10-WAY AMP MQL / NATURAL	FASCIA / DRIVER SIDE
TRUNK RELEASE SOLENOID	BT43 / 2-WAY LABINAL / BROWN	TRUNK / LEFT HAND SIDE
TRUNK SWITCH	BT46 / 2-WAY AUGAT 1.6 / BLACK	TRUNK
VALET SWITCH	FC67 / 10-WAY AMP MQL / BLACK	DRIVER KNEE BOLSTER

### RELAYS

Relay	Color / Stripe	Connector / Color	Location / Access
DOOR LOCKING RELAY	BLACK	FC24 / BLACK	RH FASCIA RELAYS

### HARNESSTO-HARNESSTO CONNECTORS

Connector	Type / Color	Location / Access
AC13	20-WAY MULTILOCK 070 / YELLOW	FASCIA BOTTOM CONNECTOR MOUNTING BRACKET / RIGHT HAND SIDE
AC14	14-WAY MULTILOCK 070 / GREY	FASCIA BOTTOM CONNECTOR MOUNTING BRACKET / RIGHT HAND SIDE
AC15	20-WAY MULTILOCK 070 / GREY	FASCIA BOTTOM CONNECTOR MOUNTING BRACKET / RIGHT HAND SIDE
BT1	20-WAY MULTILOCK 070 / WHITE	TRUNK / ABOVE RIGHT HAND REAR WHEEL ARCH
BT2	20-WAY MULTILOCK 070 / WHITE	TRUNK / ABOVE RIGHT HAND REAR WHEEL ARCH
DD1	23-WAY AMP – FORD / BLACK	DRIVER SIDE 'A' POST MOUNTING BRACKET/ 'A' POST TRIM
DP1	23-WAY AMP – FORD / BLACK	PASSENGER SIDE 'A' POST / 'A' POST TRIM
IC4	4-WAY MULTILOCK 070 / WHITE	TRUNK / LEFT OF ANTENNA ASSEMBLY
RH2	20-WAY MULTILOCK 070 / WHITE	REAR OF CENTER CONSOLE ASSEMBLY

### GROUNDSTO

Ground	Location / Type
BT1AL	EYELET (PAIR) – LEFT HAND LEG / ADJACENT TO BATTERY
BT1AR	EYELET (PAIR) – RIGHT HAND LEG / ADJACENT TO BATTERY
FC2AR	EYELET (PAIR) – RIGHT HAND LEG / RIGHT HAND 'A' POST
FC2BL	EYELET (PAIR) – LEFT HAND LEG / RIGHT HAND 'A' POST
FC2BR	EYELET (PAIR) – RIGHT HAND LEG / RIGHT HAND 'A' POST
FC3BL	EYELET (PAIR) – LEFT HAND LEG / TRANSMISSION TUNNEL, LEFT HAND SIDE
FC3BR	EYELET (PAIR) – RIGHT HAND LEG / TRANSMISSION TUNNEL, LEFT HAND SIDE
FC4AR	EYELET (PAIR) – RIGHT HAND LEG / LEFT HAND 'A' POST
FC4BL	EYELET (PAIR) – LEFT HAND LEG / LEFT HAND 'A' POST
FC4BR	EYELET (PAIR) – RIGHT HAND LEG / LEFT HAND 'A' POST
RH3S	EYELET (SINGLE) / ROOF, ADJACENT TO BACKLIGHT

FOR CONTROL MODULE PIN OUT INFORMATION, UNFOLD PAGE TO LEFT.

Refer to the front of this book for detailed information and illustrations regarding the location and identification of harnesses, relays, grounds, control modules and control module pins.

**CONTROL MODULE PIN OUT INFORMATION**

**Fig. 14.1**

**BODY PROCESSOR MODULE**

Pin	Description	Active	Inactive
I FC14-6	WASHER FLUID LEVEL LOW	0 V	B+
I FC14-9	INTERMITTENT WIPER REQUEST	GROUND (MOMENTARY)	B+
I FC14-15	IGNITION SWITCHED GROUND SUPPLY	GROUND	
I FC14-16	SIDE LAMP REQUEST	GROUND	B+
O FC14-18	POWERWASH RELAY ACTIVATE	GROUND	B+
O FC14-19	WIPER FAST / SLOW RELAY ACTIVATE	GROUND	B+
O FC14-26	WINDSHIELD WASH PUMP AND FLUID LEVEL SENSOR SUPPLY	B+	GROUND
I FC14-34	FAST WIPE REQUEST	GROUND	B+
I FC14-37	WASH REQUEST	0 V (MOMENTARY)	B+
O FC14-43	WIPER RUN / STOP RELAY ACTIVATE	GROUND	B+
I FC14-60	WIPER MOTOR PARK SWITCH	GROUND (PARKED)	B+ (NOT PARKED)
I FC14-80	BATTERY POWER SUPPLY (LOGIC)	B+	B+
I FC14-94	SLOW WIPE REQUEST	GROUND (WIPERS ON)	B+
I FC14-104	LIGHTING / MOTORS BATTERY POWER SUPPLY	B+	B+

**COMPONENTS**

Component	Connector / Type / Color	Location / Access
BODY PROCESSOR MODULE	FC14 / 104-WAY AMP EEEEC / GREY	PASSENGER SIDE FASCIA / AIRBAG BRACKET
FUSE BOX - ENGINE COMPARTMENT	LF5 / 10-WAY U.T.A. FUSEBOX / NATURAL LF6 / 10-WAY U.T.A. FUSEBOX / BLACK LF7 / 10-WAY U.T.A. FUSEBOX / GREEN LF8 / 10-WAY U.T.A. FUSEBOX / BLUE LF70 / EYELET	ENGINE COMPARTMENT / LEFT FRONT
INTERIOR REAR VIEW MIRROR	RF2 / 6-WAY MULTILOCK 070 / YELLOW	WINDSHIELD / FORWARD OF ROOF CONSOLE
LIGHTING STALK (COLUMN SWITCHGEAR)	SC2 / 10-WAY MULTILOCK 070 / YELLOW	STEERING COLUMN
POWERWASH PUMP	LF25 / 2-WAY ECONOSEAL III HC / BLACK	LEFT FRONT FENDER / WHEEL ARCH LINER
RAIN SENSING MODULE	RS1 / 12-WAY AMP ML42 / BLACK	ABOVE PASSENGER FOOTWELL
RAIN SENSOR	RF15 / 3-WAY MICRO QUAD LOCK / BLACK	BEHIND REAR VIEW MIRROR
WASH / WIPE STALK (COLUMN SWITCHGEAR)	SC1 / 12-WAY MULTILOCK 070 / WHITE	STEERING COLUMN
WINDSHIELD WASH PUMP AND FLUID LEVEL SENSOR	LF27 / 3-WAY AUGAT 1.6 / BLACK	LEFT FRONT FENDER / WHEEL ARCH LINER
WIPER MOTOR	EM51 / 5-WAY FORD FAO / BLACK	BASE OF WINDSHIELD / AIR INTAKE PLENUM

**RELAYS**

Relay	Color / Stripe	Connector / Color	Location / Access
WIPER RUN / STOP RELAY	BLACK	LF48 / BLACK	LH ENCLOSURE RELAYS
WIPER FAST / SLOW RELAY	BLACK	LF49 / BLACK	LH ENCLOSURE RELAYS
POWERWASH RELAY (#4)	BROWN	BUS	ENGINE COMPARTMENT FUSE BOX

**HARNESSTO-HARNESSTO CONNECTORS**

Connector	Type / Color	Location / Access
EM2	20-WAY MULTILOCK 070 / YELLOW	ENGINE COMPARTMENT / ADJACENT TO RIGHT HAND ENCLOSURE
FC49	12-WAY MULTILOCK 040 /BLACK	FASCIA
LF3	13-WAY ECONOSEAL III LC / WHITE	ENGINE COMPARTMENT / LEFT HAND ENCLOSURE
LF1	20-WAY MULTILOCK 070 / GREY	LEFT HAND 'A' POST CONNECTOR MOUNTING BRACKET / 'A' POST TRIM
LF60	20-WAY MULTILOCK 070 / WHITE	LEFT HAND 'A' POST CONNECTOR MOUNTING BRACKET / 'A' POST TRIM
RF1	18-WAY MULTILOCK 070 / YELLOW	RIGHT HAND 'A' POST CONNECTOR MOUNTING BRACKET / 'A' POST TRIM

**GROUNDST**

Ground	Location / Type
FC3BL	EYELET (PAIR) - LEFT HAND LEG / TRANSMISSION TUNNEL, LEFT HAND SIDE
FC3BR	EYELET (PAIR) - RIGHT HAND LEG / TRANSMISSION TUNNEL, LEFT HAND SIDE
LF1AR	EYELET (PAIR) - RIGHT HAND LEG / RIGHT HAND HEADLAMP
LF3BS	EYELET (SINGLE) / ENGINE COMPARTMENT, FORWARD OF LEFT HAND HOOD CATCH

FOR CONTROL MODULE PIN OUT INFORMATION, UNFOLD PAGE TO LEFT.

The following abbreviations are used to represent values for Control Module Pin-Out data

I	Input	D	Serial and Encoded Data	B+	Battery Voltage	kHz	Frequency x 1000
O	Output	C	CAN (Network)	V	Voltage (DC)	ms	Milliseconds
SG	Signal Ground	S	SCP Network	Hz	Frequency	mV	Millivolts

CAUTION: The information on this data page is furnished to aid the user in understanding circuit operation. THIS INFORMATION SHOULD BE USED FOR REFERENCE ONLY.

NOTE: The values listed are approximately those that can be expected at the control module connector pins with all circuit connections made and all components connected and fitted. "Active" means a load is applied or a switch is ON; "Inactive" means a load is not applied or a switch is OFF.

Refer to the front of this book for detailed information and illustrations regarding the location and identification of harnesses, relays, grounds, control modules and control module pins.

**Fig. 15.1**

**CONTROL MODULE PIN OUT INFORMATION**

**BODY PROCESSOR MODULE**

Pin	Description	Active	Inactive
S FC14-84	SCP NETWORK	2 – 1600 Hz	
S FC14-85	SCP NETWORK	2 – 1600 Hz	

**DRIVER DOOR CONTROL MODULE**

Pin	Description	Active	Inactive
I DD10-1	BATTERY POWER SUPPLY	B+	B+
O DD10-7	WINDOW LIFT MOTOR DOWN SUPPLY	B+	GROUND
I DD10-8	LOGIC GROUND	GROUND	GROUND
S DD10-9	SCP NETWORK	2 – 1600 Hz	
I DD10-10	DRIVER SWITCH PACK LH WINDOW DOWN REQUEST	GROUND (MOMENTARY)	B+
I DD10-11	DRIVER WINDOW LIFT SENSOR FEEDBACK	2 V = UP; 12 V = DOWN	
I DD10-12	DRIVER WINDOW LIFT SENSOR FEEDBACK	2 V = UP; 12 V = DOWN	
O DD10-13	DRIVER WINDOW LIFT SENSOR REFERENCE VOLTAGE	B+	B+
O DD10-15	DRIVER WINDOW LIFT MOTOR UP SUPPLY	B+	GROUND
S DD10-16	SCP NETWORK	2 – 1600 Hz	
I DD10-17	POWER GROUND	GROUND	GROUND
I DD10-18	DRIVER SWITCH PACK LH WINDOW UP REQUEST	GROUND (MOMENTARY)	GROUND
I DD10-19	DRIVER SWITCH PACK RH WINDOW UP REQUEST	GROUND (MOMENTARY)	GROUND
I DD11-4	DRIVER DOOR LOCK BARREL UNLOCK REQUEST	B+ (MOMENTARY)	GROUND
I DD11-7	DRIVER SWITCH PACK RH WINDOW DOWN REQUEST	B+ (MOMENTARY)	GROUND
I DD11-12	DRIVER DOOR LOCK BARREL LOCK REQUEST	B+ (MOMENTARY)	GROUND

**MAJOR INSTRUMENT PACK**

Pin	Description	Active	Inactive
S FC25-13	SCP NETWORK	2 – 1600 Hz	
S FC25-14	SCP NETWORK	2 – 1600 Hz	

**PASSENGER DOOR CONTROL MODULE**

Pin	Description	Active	Inactive
I DP10-1	BATTERY POWER SUPPLY	B+	B+
O DP10-7	PASSENGER WINDOW LIFT MOTOR DOWN SUPPLY	B+	GROUND
I DP10-8	LOGIC GROUND	GROUND	GROUND
S DP10-9	SCP NETWORK	2 – 1600 Hz	
I DP10-10	PASSENGER SWITCH PACK RH WINDOW DOWN REQUEST	B+ (MOMENTARY)	GROUND
I DP10-11	PASSENGER WINDOW LIFT MOVEMENT SENSOR FEEDBACK	2 V = UP; 12 V = DOWN	
I DP10-12	PASSENGER WINDOW LIFT MOVEMENT SENSOR FEEDBACK	2 V = UP; 12 V = DOWN	
O DP10-13	PASSENGER WINDOW LIFT MOVEMENT SENSOR REFERENCE VOLTAGE	B+	B+
O DP10-15	PASSENGER WINDOW LIFT MOTOR UP SUPPLY	B+	GROUND
S DP10-16	SCP NETWORK	2 – 1600 Hz	
I DP10-17	POWER GROUND	GROUND	GROUND
I DP10-18	PASSENGER SWITCH PACK RH WINDOW UP REQUEST	B+ (MOMENTARY)	GROUND

**SECURITY AND LOCKING CONTROL MODULE**

Pin	Description	Active	Inactive
S BT40-8	SCP NETWORK	2 – 1600 Hz	
S BT40-16	SCP NETWORK	2 – 1600 Hz	

**NOTE:** Refer to the Appendix at the rear of this book for CAN and SCP Network Messages.

**COMPONENTS**

Component	Connector / Type / Color	Location / Access
BODY PROCESSOR MODULE	FC14 / 104-WAY AMP EEEEC / GREY	PASSENGER SIDE FASCIA / AIRBAG BRACKET
DOOR CONTROL MODULE – DRIVER	DD10 / 22-WAY FORD 2.8 TIMER / BLUE DD11 / 22-WAY FORD 2.8 TIMER / BLACK	DRIVER DOOR / DOOR CASING
DOOR CONTROL MODULE – PASSENGER	DP10 / 22-WAY FORD 2.8 TIMER / BLUE DP11 / 22-WAY FORD 2.8 TIMER / BLACK	PASSENGER DOOR / DOOR CASING
DOOR LOCK SWITCHES – DRIVER MAJOR INSTRUMENT PACK	DD3 / 13-WAY ECONOSEAL III LC / BLACK FC25 / 16-WAY AMP MICRO QUAD LOCK / BLACK FC26 / 26-WAY AMP MICRO QUAD LOCK / YELLOW	DRIVER DOOR / DOOR CASING FASCIA
SECURITY AND LOCKING CONTROL MODULE	BT40 / 16-WAY FORD 2.8 TIMER / BLACK BT41 / 26-WAY FORD IDC / BLACK RH20 / COAXIAL CONNECTOR	TRUNK / ELECTRICAL CARRIER
WINDOW LIFT SWITCHES – DRIVER DOOR WINDOW LIFT SWITCHES – PASSENGER DOOR (PASSENGER DOOR SWITCH PACK)	DD17 / 20-WAY MULTILOCK 040 / BLACK DP17 / 20-WAY MULTILOCK 040 / BLACK	DRIVER DOOR SWITCH PACK PASSENGER DOOR SWITCH PACK
WINDOW LIFT – DRIVER WINDOW LIFT – PASSENGER	DD16 / 6-WAY ECONOSEAL III LC / BLACK DP16 / 6-WAY ECONOSEAL III LC / BLACK	DRIVER DOOR DRIVER DOOR

**HARNESS-TO-HARNESS CONNECTORS**

Connector	Type / Color	Location / Access
AC14	14-WAY MULTILOCK 070 / GREY	FASCIA BOTTOM CONNECTOR MOUNTING BRACKET / RIGHT HAND SIDE
AC15	20-WAY MULTILOCK 070 / GREY	FASCIA BOTTOM CONNECTOR MOUNTING BRACKET / RIGHT HAND SIDE
AC16	6-WAY MULTILOCK 070 / YELLOW	LEFT HAND 'A' POST CONNECTOR MOUNTING BRACKET / 'A' POST TRIM
BT1	20-WAY MULTILOCK 070 / WHITE	TRUNK / ABOVE RIGHT HAND REAR WHEEL ARCH
BT2	20-WAY MULTILOCK 070 / WHITE	TRUNK / ABOVE RIGHT HAND REAR WHEEL ARCH
DD1	23-WAY AMP – FORD / BLACK	DRIVER SIDE 'A' POST MOUNTING BRACKET / 'A' POST TRIM
DP1	23-WAY AMP – FORD / BLACK	PASSENGER SIDE 'A' POST / 'A' POST TRIM
FC62	10-WAY AMP MQL / BLACK	CONVERTIBLE TOP SWITCH
RF1	18-WAY MULTILOCK 070 / YELLOW	RIGHT HAND 'A' POST CONNECTOR MOUNTING BRACKET / 'A' POST TRIM
RH12	18-WAY MULTILOCK 070 / YELLOW	REAR OF CENTER CONSOLE ASSEMBLY
RH2	20-WAY MULTILOCK 070 / WHITE	REAR OF CENTER CONSOLE ASSEMBLY

**GROUNDS**

Ground	Location / Type
FC2AR	EYELET (PAIR) – RIGHT HAND LEG / RIGHT HAND 'A' POST
FC4AR	EYELET (PAIR) – RIGHT HAND LEG / LEFT HAND 'A' POST

**FOR CONTROL MODULE PIN OUT INFORMATION, UNFOLD PAGE TO LEFT.**

The following abbreviations are used to represent values for Control Module Pin-Out data

I	Input	D	Serial and Encoded Data	B+	Battery Voltage	kHz	Frequency x 1000
O	Output	C	CAN (Network)	V	Voltage (DC)	ms	Milliseconds
SG	Signal Ground	S	SCP Network	Hz	Frequency	mV	Millivolts

**CAUTION:** The information on this data page is furnished to aid the user in understanding circuit operation. THIS INFORMATION SHOULD BE USED FOR REFERENCE ONLY.

**NOTE:** The values listed are approximately those that can be expected at the control module connector pins with all circuit connections made and all components connected and fitted. "Active" means a load is applied or a switch is ON; "Inactive" means a load is not applied or a switch is OFF.

Refer to the front of this book for detailed information and illustrations regarding the location and identification of harnesses, relays, grounds, control modules and control module pins.



**CONTROL MODULE PIN OUT INFORMATION**

**Fig. 15.2**

**BODY PROCESSOR MODULE**

Pin	Description	Active	Inactive
I FC14-10	CONVERTIBLE TOP RAISE REQUEST	GROUND (MOMENTARY)	B+
I FC14-15	IGNITION SWITCHED GROUND SUPPLY	GROUND	GROUND
I FC14-32	IGNITION SWITCHED GROUND SUPPLY	GROUND	GROUND
I FC14-33	IGNITION SWITCHED GROUND SUPPLY	GROUND	GROUND
I FC14-36	CONVERTIBLE TOP READY TO LATCH	GROUND	B+
I FC14-62	CONVERTIBLE TOP LATCH CLOSED	GROUND (CLOSED)	B+
I FC14-63	CONVERTIBLE TOP LOWER REQUEST	GROUND (MOMENTARY)	B+
O FC14-77	REAR QUARTER GLASS DOWN RELAYS ACTIVATE	GROUND	B+
I FC14-80	BATTERY POWER SUPPLY (LOGIC)	B+	B+
S FC14-84	SCP NETWORK	2 - 1600 Hz	2 - 1600 Hz
S FC14-85	SCP NETWORK	2 - 1600 Hz	2 - 1600 Hz
I FC14-89	CONVERTIBLE TOP CLOSED	GROUND	B+
O FC14-98	REAR QUARTER GLASS UP RELAYS ACTIVATE	GROUND	B+

**DRIVER DOOR CONTROL MODULE**

Pin	Description	Active	Inactive
S DD10-9	SCP NETWORK	2 - 1600 Hz	
S DD10-16	SCP NETWORK	2 - 1600 Hz	

**MAJOR INSTRUMENT PACK**

Pin	Description	Active	Inactive
S FC25-13	SCP NETWORK	2 - 1600 Hz	
S FC25-14	SCP NETWORK	2 - 1600 Hz	

**PASSENGER DOOR CONTROL MODULE**

Pin	Description	Active	Inactive
S DP10-9	SCP NETWORK	2 - 1600 Hz	
S DP10-16	SCP NETWORK	2 - 1600 Hz	
C FC25-24	CAN NETWORK	15 - 1500 Hz	
C FC25-47	CAN NETWORK	15 - 1500 Hz	

**SECURITY AND LOCKING CONTROL MODULE**

Pin	Description	Active	Inactive
O BT40-3	TOP UP RELAY ACTIVATE	B+	GROUND
O BT40-4	LATCH CONTROL VALVE	B+	GROUND
I BT40-6	BATTERY POWER SUPPLY	B+	B+
S BT40-8	SCP NETWORK	2 - 1600 Hz	
O BT40-9	MAIN CONTROL VALVE	B+	GROUND
O BT40-10	TOP DOWN RELAY ACTIVATE	B+	GROUND
I BT40-13	GROUND	GROUND	GROUND
I BT40-14	GROUND	GROUND	GROUND
S BT40-16	SCP NETWORK	2 - 1600 Hz	
I BT41-3	CONVERTIBLE TOP DOWN SWITCH	GROUND	B+

**NOTE:** Refer to the Appendix at the rear of this book for CAN and SCP Network Messages.

The following abbreviations are used to represent values for Control Module Pin-Out data

I	Input	D	Serial and Encoded Data	B+	Battery Voltage	kHz	Frequency x 1000
O	Output	C	CAN (Network)	V	Voltage (DC)	ms	Milliseconds
SG	Signal Ground	S	SCP Network	Hz	Frequency	mV	Millivolts

**CAUTION:** The information on this data page is furnished to aid the user in understanding circuit operation. THIS INFORMATION SHOULD BE USED FOR REFERENCE ONLY.

**NOTE:** The values listed are approximately those that can be expected at the control module connector pins with all circuit connections made and all components connected and fitted. "Active" means a load is applied or a switch is ON; "Inactive" means a load is not applied or a switch is OFF.

**COMPONENTS**

Component	Connector / Type / Color	Location / Access
BODY PROCESSOR MODULE	FC14 / 104-WAY AMP EEEEC / GREY	PASSENGER SIDE FASCIA / AIRBAG BRACKET
CONVERTIBLE TOP CLOSED SWITCH	RF4 / 6-WAY MULTILOCK 070 / WHITE	TOP OF WINDSHIELD
CONVERTIBLE TOP DOWN SWITCH	RH29 / 3-WAY MULTILOCK 070 / WHITE	RIGHT HAND OPERATING CYLINDER
CONVERTIBLE TOP LATCH CLOSED SWITCH	RF4 / 6-WAY MULTILOCK 070 / WHITE	TOP OF WINDSHIELD
CONVERTIBLE TOP PUMP	BT15 / 2-WAY AMP / NATURAL	TRUNK / RIGHT HAND SIDE
CONVERTIBLE TOP RAISED SWITCH	RH29 / 3-WAY MULTILOCK 070 / WHITE	RIGHT HAND OPERATING CYLINDER
CONVERTIBLE TOP READY-TO-LATCH SWITCH	RF4 / 6-WAY MULTILOCK 070 / WHITE	TOP OF WINDSHIELD
CONVERTIBLE TOP SWITCH	FC62 / 10-WAY AMP MQL / BLACK	FORWARD OF GEAR SELECTOR
DOOR CONTROL MODULE - DRIVER	DD10 / 22-WAY FORD 2.8 TIMER / BLUE DD11 / 22-WAY FORD 2.8 TIMER / BLACK	DRIVER DOOR / DOOR CASING
DOOR CONTROL MODULE - PASSENGER	DP10 / 22-WAY FORD 2.8 TIMER / BLUE DP11 / 22-WAY FORD 2.8 TIMER / BLACK	PASSENGER DOOR / DOOR CASING
LATCH CONTROL VALVE	PH2 / 2-WAY DAUT & RIETZ / BLUE	TRUNK / CONVERTIBLE TOP PUMP
MAIN CONTROL VALVE	PH3 / 2-WAY DAUT & RIETZ / ORANGE	TRUNK / CONVERTIBLE TOP PUMP
MAJOR INSTRUMENT PACK	FC25 / 26-WAY AMP MICRO QUAD LOCK / BLACK FC26 / 26-WAY AMP MICRO QUAD LOCK / YELLOW	FASCIA
QUARTER LIGHT LIFT - LH	RH33 / 2-WAY ECONOSEAL III HC / BLACK	REAR QUARTER PANEL
QUARTER LIGHT LIFT - RH	RH34 / 2-WAY ECONOSEAL III HC / BLACK	REAR QUARTER PANEL
SECURITY AND LOCKING CONTROL MODULE	BT40 / 16-WAY FORD 2.8 TIMER / BLACK BT41 / 26-WAY FORD IDC / BLACK RH20 / COAXIAL CONNECTOR	TRUNK / ELECTRICAL CARRIER

**RELAYS**

Relay	Color / Stripe	Connector / Color	Location / Access
QUARTER DOWN RELAY - LH	BLACK	BT74 / BLACK	TRUNK RELAYS
QUARTER DOWN RELAY - RH	BLACK	BT76 / BLACK	TRUNK RELAYS
QUARTER UP RELAY - LH	BLACK	BT74 / BLACK	TRUNK RELAYS
QUARTER UP RELAY - RH	BLACK	BT76 / BLACK	TRUNK RELAYS
TOP UP RELAY	BLACK	BT16 / BLACK	TRUNK RELAYS
TOP DOWN RELAY	BLACK	BT17 / BLACK	TRUNK RELAYS

**HARNESSTO-HARNESSTO CONNECTORS**

Connector	Type / Color	Location / Access
AC14	14-WAY MULTILOCK 070 / GREY	FASCIA BOTTOM CONNECTOR MOUNTING BRACKET / RIGHT HAND SIDE
BT1	20-WAY MULTILOCK 070 / WHITE	TRUNK / ABOVE RIGHT HAND REAR WHEEL ARCH
BT3	18-WAY MULTILOCK 070 / YELLOW	TRUNK / ABOVE RIGHT HAND REAR WHEEL ARCH
DD1	23-WAY AMP - FORD / BLACK	DRIVER SIDE 'A' POST MOUNTING BRACKET / 'A' POST TRIM
DP1	23-WAY AMP - FORD / BLACK	PASSENGER SIDE 'A' POST / 'A' POST TRIM
PH1	3-WAY MULTILOCK 070 / YELLOW	TRUNK
RF1	18-WAY MULTILOCK 070 / YELLOW	RIGHT HAND 'A' POST CONNECTOR MOUNTING BRACKET / 'A' POST TRIM
RH2	20-WAY MULTILOCK 070 / WHITE	REAR OF CENTER CONSOLE ASSEMBLY
RH5	3-WAY MULTILOCK 070 / WHITE	BEHIND LEFT HAND QUARTER TRIM PANEL
RH6	3-WAY MULTILOCK 070 / WHITE	BEHIND RIGHT HAND QUARTER TRIM PANEL
RH12	18-WAY MULTILOCK 070 / YELLOW	REAR OF CENTER CONSOLE ASSEMBLY

**GROUND**

Ground	Location / Type
BT1AL	EYELET (PAIR) - LEFT HAND LEG / ADJACENT TO BATTERY
BT1AR	EYELET (PAIR) - RIGHT HAND LEG / ADJACENT TO BATTERY
BT1BL	EYELET (PAIR) - LEFT HAND LEG / ADJACENT TO BATTERY
BT1BR	EYELET (PAIR) - RIGHT HAND LEG / ADJACENT TO BATTERY
BT2BL	EYELET (PAIR) - LEFT HAND LEG / TRUNK, RIGHT REAR
FC3BR	EYELET (PAIR) - RIGHT HAND LEG / TRANSMISSION TUNNEL, LEFT HAND SIDE
RH1S	EYELET (SINGLE) / RIGHT HAND REAR QUARTER

**FOR CONTROL MODULE PIN OUT INFORMATION, UNFOLD PAGE TO LEFT.**

Refer to the front of this book for detailed information and illustrations regarding the location and identification of harnesses, relays, grounds, control modules and control module pins.

CONTROL MODULE PIN OUT INFORMATION

MAJOR INSTRUMENT PACK

Pin	Description	Active	Inactive
C	FC25-11 CAN NETWORK	15 - 1500 Hz	
C	FC25-23 CAN NETWORK	15 - 1500 Hz	
O	FC26-20 VEHICLE SPEED	22 Hz @ 10 MPH (16 KMH); 44 Hz @ 20 MPH (32 KMH) @ B+	

NOTE: Refer to the Appendix at the rear of this book for CAN and SCP Network Messages.

Fig. 16.1

COMPONENTS

Component	Connector / Type / Color	Location / Access
ANTENNA MOTOR	BT19 / 6-WAY YAZAKI C.S.U. / WHITE	TRUNK / RIGHT HAND SIDE
CD AUTO-CHANGER	IC7 / 8-WAY ALPINE	TRUNK / RIGHT HAND SIDE
MAJOR INSTRUMENT PACK	FC25 / 26-WAY AMP MICRO QUAD LOCK / BLACK FC26 / 26-WAY AMP MICRO QUAD LOCK / YELLOW	FASCIA
RADIO / CASSETTE HEAD UNIT	IC8 / 8-WAY ALPINE / BLACK IC19 / 12-WAY MULTILOCK 070 / WHITE IC20 / 26-WAY MOS / YELLOW	CENTER CONSOLE
RADIO ANTENNA	IC12 / COAXIAL CONNECTOR	TRUNK / RIGHT HAND SIDE
RADIO CONTROL SWITCHES (STEERING WHEEL)	SW4 / 3-WAY EPC / BLACK	STEERING WHEEL
SPEAKER - DRIVER DOOR (MID-BASS)	DD19 / 2-WAY GROTE AND HARTMAN MDK / BLACK	DRIVER DOOR CASING
SPEAKER - PASSENGER DOOR (MID-BASS)	DP19 / 2-WAY GROTE AND HARTMAN MDK / BLACK	PASSENGER DOOR CASING
SPEAKER - LH SIDE FASCIA	FC38 / 2-WAY MULTILOCK 070 / GREY	FASCIA / LH SIDE
SPEAKER - RH SIDE FASCIA	FC39 / 2-WAY MULTILOCK 070 / GREY	FASCIA / RH SIDE
SPEAKER - LH SIDE REAR (CONVERTIBLE)	RH26 / 2-WAY GROTE AND HARTMAN MDK / BLACK	INTERIOR REAR QUARTER PANEL
SPEAKER - RH SIDE REAR (CONVERTIBLE)	RH27 / 2-WAY GROTE AND HARTMAN MDK / BLACK	INTERIOR REAR QUARTER PANEL
SPEAKER - LH SIDE REAR QUARTER (COUPE)	RH30 / 2-WAY GROTE AND HARTMAN MDK / BLACK	INTERIOR REAR QUARTER PANEL
SPEAKER - RH SIDE REAR QUARTER (COUPE)	RH31 / 2-WAY GROTE AND HARTMAN MDK / BLACK	INTERIOR REAR QUARTER PANEL

HARNESSTO-HARNESSTO CONNECTORS

Connector	Type / Color	Location / Access
AC14	14-WAY MULTILOCK 070 / GREY	FASCIA BOTTOM CONNECTOR MOUNTING BRACKET / RIGHT HAND SIDE
BT1	20-WAY MULTILOCK 070 / WHITE	TRUNK / ABOVE RIGHT HAND REAR WHEEL ARCH
DD1	23-WAY AMP - FORD / BLACK	DRIVER SIDE 'A' POST MOUNTING BRACKET/ 'A' POST TRIM
DP1	23-WAY AMP - FORD / BLACK	PASSENGER SIDE 'A' POST / 'A' POST TRIM
IC1	20-WAY MULTILOCK 070 / YELLOW	BELOW CENTER CONSOLE GLOVE BOX
IC2	14-WAY MULTILOCK 070 / WHITE	BELOW CENTER CONSOLE GLOVE BOX
RH1	20-WAY MULTILOCK 070 / GREY	BEHIND GLOVE BOX
SC2	10-WAY MULTILOCK 070 / YELLOW	ADJACENT TO STEERING COLUMN MOTOR
SC3	12-WAY MULTILOCK 070 / GREY	RIGHT HAND SIDE OF STEERING COLUMN
SW1	12-WAY MULTILOCK 040 / BLACK	INSIDE STEERING COLUMN COWL
SW2	6-WAY JST / WHITE	CENTER OF STEERING WHEEL

GROUNDSTO

Ground	Location / Type
BT1AL	EYELET (PAIR) - LEFT HAND LEG / ADJACENT TO BATTERY
CE2	EYELET (SINGLE) / ABOVE RIGHT HAND SIDE OF TRANSMISSION TUNNEL
FC3BL	EYELET (PAIR) - LEFT HAND LEG / TRANSMISSION TUNNEL, LEFT HAND SIDE

FOR CONTROL MODULE PIN OUT INFORMATION, UNFOLD PAGE TO LEFT.

The following abbreviations are used to represent values for Control Module Pin-Out data

I	Input	D	Serial and Encoded Data	B+	Battery Voltage	kHz	Frequency x 1000
O	Output	C	CAN (Network)	V	Voltage (DC)	ms	Milliseconds
SG	Signal Ground	S	SCP Network	Hz	Frequency	mV	Millivolts

CAUTION: The information on this data page is furnished to aid the user in understanding circuit operation. THIS INFORMATION SHOULD BE USED FOR REFERENCE ONLY.

NOTE: The values listed are approximately those that can be expected at the control module connector pins with all circuit connections made and all components connected and fitted. "Active" means a load is applied or a switch is ON; "Inactive" means a load is not applied or a switch is OFF.

Refer to the front of this book for detailed information and illustrations regarding the location and identification of harnesses, relays, grounds, control modules and control module pins.

CONTROL MODULE PIN OUT INFORMATION

MAJOR INSTRUMENT PACK

Pin	Description	Active	Inactive
C	FC25-11 CAN NETWORK	15 - 1500 Hz	
C	FC25-11 CAN NETWORK	15 - 1500 Hz	
O	FC25-11 VEHICLE SPEED	22 Hz @ 10 MPH (16 KMH); 44 Hz @ 20 MPH (32 KMH) @ B+	

NOTE: Refer to the Appendix at the rear of this book for CAN and SCP Network Messages.

Fig. 16.2

COMPONENTS

Component	Connector / Type / Color	Location / Access
ANTENNA MOTOR	BT19 / 6-WAY YAZAKI C.S.U. / WHITE	TRUNK / RIGHT HAND SIDE
CD AUTO-CHANGER	IC7 / 8-WAY ALPINE	TRUNK / RIGHT HAND SIDE
MAJOR INSTRUMENT PACK	FC25 / 26-WAY AMP MICRO QUAD LOCK / BLACK FC26 / 26-WAY AMP MICRO QUAD LOCK / YELLOW	FASCIA
POWER AMPLIFIER	IC7 / 8-WAY ALPINE / BLACK IC15 / 18-WAY / MULTILOCK 070 / WHITE IC16 / 12-WAY MULTILOCK 070 / WHITE	TRUNK / RIGHT HAND SIDE
RADIO / CASSETTE HEAD UNIT	IC8 / 8-WAY ALPINE / BLACK IC19 / 12-WAY MULTILOCK 070 / WHITE IC20 / 26-WAY MOS / YELLOW	CENTER CONSOLE
RADIO ANTENNA	IC12 / COAXIAL CONNECTOR	TRUNK / RIGHT HAND SIDE
RADIO CONTROL SWITCHES (STEERING WHEEL)	SW4 / 3-WAY EPC / BLACK	STEERING WHEEL
SPEAKER - DRIVER DOOR (MID-BASS)	DD19 / 2-WAY GROTE AND HARTMAN MDK / BLACK	DRIVER DOOR CASING
SPEAKER - PASSENGER DOOR (MID-BASS)	DP19 / 2-WAY GROTE AND HARTMAN MDK / BLACK	PASSENGER DOOR CASING
SPEAKER - DRIVER DOOR (TWEETER)	DD18 / 2-WAY MULTILOCK 040 / BLACK	DRIVER DOOR
SPEAKER - PASSENGER DOOR (TWEETER)	DP18 / 2-WAY MULTILOCK 040 / BLACK	PASSENGER DOOR
SPEAKER - LH SIDE FASCIA	FC38 / 2-WAY MULTILOCK 070 / GREY	FASCIA / LH SIDE
SPEAKER - RH SIDE FASCIA	FC39 / 2-WAY MULTILOCK 070 / GREY	FASCIA / RH SIDE
SPEAKER - LH SIDE REAR (CONVERTIBLE)	RH26 / 2-WAY GROTE AND HARTMAN MDK / BLACK	INTERIOR REAR QUARTER PANEL
SPEAKER - RH SIDE REAR (CONVERTIBLE)	RH27 / 2-WAY GROTE AND HARTMAN MDK / BLACK	INTERIOR REAR QUARTER PANEL
SPEAKER - LH SIDE REAR QUARTER (COUPE)	RH30 / 2-WAY GROTE AND HARTMAN MDK / BLACK	INTERIOR REAR QUARTER PANEL
SPEAKER - RH SIDE REAR QUARTER (COUPE)	RH31 / 2-WAY GROTE AND HARTMAN MDK / BLACK	INTERIOR REAR QUARTER PANEL
SPEAKER - REAR (COUPE)	RH26 / 2-WAY GROTE AND HARTMAN MDK / BLACK RH27 / 2-WAY GROTE AND HARTMAN MDK / BLACK	PARCEL SHELF

HARNESSTO-HARNESSTO CONNECTORS

Connector	Type / Color	Location / Access
AC14	14-WAY MULTILOCK 070 / GREY	FASCIA BOTTOM CONNECTOR MOUNTING BRACKET / RIGHT HAND SIDE
BT1	20-WAY MULTILOCK 070 / WHITE	TRUNK / ABOVE RIGHT HAND REAR WHEEL ARCH
DD1	23-WAY AMP - FORD / BLACK	DRIVER SIDE 'A' POST MOUNTING BRACKET/ 'A' POST TRIM
DP1	23-WAY AMP - FORD / BLACK	PASSENGER SIDE 'A' POST / 'A' POST TRIM
IC1	20-WAY MULTILOCK 070 / YELLOW	BELOW CENTER CONSOLE GLOVE BOX
IC2	14-WAY MULTILOCK 070 / WHITE	BELOW CENTER CONSOLE GLOVE BOX
IC4	4-WAY MULTILOCK 070 / WHITE	TRUNK / LEFT OF ANTENNA ASSEMBLY
RH1	20-WAY MULTILOCK 070 / GREY	BEHIND GLOVE BOX
SC3	12-WAY MULTILOCK 070 / GREY	RIGHT HAND SIDE OF STEERING COLUMN
SW1	12-WAY MULTILOCK 040 / BLACK	INSIDE STEERING COLUMN COWL
SW2	6-WAY JST / WHITE	CENTER OF STEERING WHEEL

GROUNDS

Ground	Location / Type
BT1AL	EYELET (PAIR) - LEFT HAND LEG / ADJACENT TO BATTERY
BT1AR	EYELET (PAIR) - RIGHT HAND LEG / ADJACENT TO BATTERY
BT1CS	EYELET (SINGLE) / ADJACENT TO BATTERY
CE2	EYELET (SINGLE) / ABOVE RIGHT HAND SIDE OF TRANSMISSION TUNNEL
FC3BL	EYELET (PAIR) - LEFT HAND LEG / TRANSMISSION TUNNEL, LEFT HAND SIDE

FOR CONTROL MODULE PIN OUT INFORMATION, UNFOLD PAGE TO LEFT.

The following abbreviations are used to represent values for Control Module Pin-Out data

I	Input	D	Serial and Encoded Data	B+	Battery Voltage	kHz	Frequency x 1000
O	Output	C	CAN (Network)	V	Voltage (DC)	ms	Milliseconds
SG	Signal Ground	S	SCP Network	Hz	Frequency	mV	Millivolts

CAUTION: The information on this data page is furnished to aid the user in understanding circuit operation. THIS INFORMATION SHOULD BE USED FOR REFERENCE ONLY.

NOTE: The values listed are approximately those that can be expected at the control module connector pins with all circuit connections made and all components connected and fitted. "Active" means a load is applied or a switch is ON; "Inactive" means a load is not applied or a switch is OFF.

Refer to the front of this book for detailed information and illustrations regarding the location and identification of harnesses, relays, grounds, control modules and control module pins.

**Fig. 17.1****COMPONENTS****Component**

CELLULAR TELEPHONE CONTROL MODULE

HANDSET

MICROPHONE

TELEPHONE ANTENNA

**Connector / Type / Color**

RT2 / 12-WAY MULTILOCK 42 / BLACK

RT5 / 16-WAY MULTILOCK 42 / BLACK

RT4 / TELEPHONE / PROPRIETARY

RF9 / 2-WAY MULTILOCK 040 / BLUE

RT7 / COAXIAL

**Location / Access**

CENTER CONSOLE

CENTER CONSOLE

ROOF CONSOLE

TRUNK / RIGHT HAND SIDE

**HARNESS-TO-HARNESS CONNECTORS****Connector**

IC2

RF1

RT3

RT6

**Type / Color**

14-WAY MULTILOCK 070 / WHITE

18-WAY MULTILOCK 070 / YELLOW

TELEPHONE / PROPRIETARY

TELEPHONE / PROPRIETARY

**Location / Access**

BELOW CENTER CONSOLE GLOVE BOX

RIGHT HAND 'A' POST CONNECTOR MOUNTING BRACKET / 'A' POST TRIM

CENTER CONSOLE

CENTER CONSOLE

**GROUND S****Ground**

FC2CS

FC4CS

**Location / Type**

EYELET (SINGLE) / RIGHT HAND 'A' POST

EYELET (SINGLE) / LEFT HAND 'A' POST

Refer to the front of this book for detailed information and illustrations regarding the location and identification of harnesses, relays, grounds, control modules and control module pins.

**Fig. 17.2****COMPONENTS**

Component	Connector / Type / Color	Location / Access
CD AUTO-CHANGER NAVIGATION CONTROL MODULE	IC7 / 8-WAY ALPINE / BLACK IC22 / 16-WAY AMP ML42 / BLACK IC23 / 24-WAY AMP ML42 / BLACK	TRUNK / RIGHT HAND SIDE
NAVIGATION DISPLAY	FC97 / 12-WAY AMP ML42 / BLACK FC98 / 16-WAY AMP ML42 / BLACK	BEHIND NAVIGATION DISPLAY
NAVIGATION GPS ANTENNA POWER AMPLIFIER	IC5 / 2-WAY HIROSE COAX GT5 SERIES / GREY IC7 / 8-WAY ALPINE / BLACK IC15 / 18-WAY / MULTILOCK 070 / WHITE IC16 / 12-WAY MULTILOCK 070 / WHITE	BELOW PARCEL SHELF TRUNK / RIGHT HAND SIDE
RADIO / CASSETTE HEAD UNIT	IC8 / 8-WAY ALPINE / BLACK IC19 / 12-WAY MULTILOCK 070 / WHITE IC20 / 26-WAY MQS / YELLOW	CENTER CONSOLE
VEHICLE SPEED INTERFACE MODULE	EM74 / 42-WAY / BLUE	ENGINE COMPARTMENT / CONTROL MODULE ENCLOSURE

**HARNESSTO-HARNESSTO CONNECTORS**

Connector	Type / Color	Location / Access
EM2	20-WAY MULTILOCK 070 / YELLOW	ENGINE COMPARTMENT / ADJACENT TO RIGHT HAND ENCLOSURE
IC1	20-WAY MULTILOCK 070 / YELLOW	BELOW CENTER CONSOLE GLOVE BOX
IC3	14-WAY MULTILOCK 070 / GREY	BELOW CENTER CONSOLE GLOVE BOX
IC4	4-WAY MULTILOCK 070 / WHITE	TRUNK / LEFT OF ANTENNA ASSEMBLY

**GROUND**

Ground	Location / Type
BT2AR	EYELET (PAIR) – RIGHT HAND LEG / TRUNK, RIGHT REAR
EM1AL	EYELET (PAIR) – LEFT HAND LEG / ENGINE COMPARTMENT, RIGHT HAND ENCLOSURE
EM2AL	EYELET (PAIR) – LEFT HAND LEG / ENGINE COMPARTMENT, LEFT HAND ENCLOSURE
FC3BL	EYELET (PAIR) – LEFT HAND LEG / TRANSMISSION TUNNEL, LEFT HAND SIDE

Refer to the front of this book for detailed information and illustrations regarding the location and identification of harnesses, relays, grounds, control modules and control module pins.

**Fig. 17.3**

**COMPONENTS**

Component	Connector / Type / Color	Location / Access
NAVIGATION CONTROL MODULE	IC7 / 8-WAY ALPINE / BLACK IC22 / 16-WAY AMP ML42 / BLACK IC23 / 24-WAY AMP ML42 / BLACK	TRUNK / RIGHT HAND SIDE
NAVIGATION DISPLAY	FC97 / 12-WAY AMP ML42 / BLACK FC98 / 16-WAY AMP ML42 / BLACK	BEHIND NAVIGATION DISPLAY
NAVIGATION GPS ANTENNA	IC5 / 2-WAY HIROSE COAX GT5 SERIES / GREY	BELOW PARCEL SHELF
PARKING BRAKE SWITCH	FC19 / 1-WAY LUCAR POSILOCK / BLACK	BELOW PARKING BRAKE LEVER
POWER AMPLIFIER	IC7 / 8-WAY ALPINE / BLACK IC15 / 18-WAY / MULTILOCK 070 / WHITE IC16 / 12-WAY MULTILOCK 070 / WHITE	TRUNK / RIGHT HAND SIDE
RADIO / CASSETTE HEAD UNIT	IC8 / 8-WAY ALPINE / BLACK IC19 / 12-WAY MULTILOCK 070 / WHITE IC20 / 26-WAY MQS / YELLOW	CENTER CONSOLE
TELEVISION ANTENNA - RH #1	TV4 / 1-WAY / METALLIC	REAR WINDOW
TELEVISION ANTENNA - RH #2	TV34 / 1-WAY / METALLIC	REAR WINDOW
TELEVISION ANTENNA - LH #3	TV3 / 1-WAY / METALLIC	REAR WINDOW
TELEVISION ANTENNA - LH #4	TV35 / 1-WAY / METALLIC	REAR WINDOW
TELEVISION ANTENNA AMPLIFIER	TV20 / 2-WAY / METALLIC TV21 / 2-WAY / METALLIC TV22 / 2-WAY / METALLIC TV23 / 2-WAY / METALLIC TV31 / 1-WAY BUTTON CONNECTOR / BLACK TV32 / 1-WAY BUTTON CONNECTOR / BLACK	ABOVE LH REAR INNER WHEEL ARCH
TELEVISION MODULE	TV5 / 2-WAY / METALLIC TV6 / 2-WAY / METALLIC TV7 / 2-WAY / METALLIC TV8 / 2-WAY / METALLIC	ON TRUNK FUSE BOX HOUSING
VEHICLE INFORMATION CONTROL BEACON MODULE	TV10 / 8-WAY / BLACK	SPARE WHEEL WELL
VEHICLE INFORMATION CONTROL INFRARED SENSOR	IR1 / 2-WAY HIROSE COAX GT5 SERIES / GREY	BELOW CENTER CONSOLE GLOVE BOX
VEHICLE INFORMATION CONTROL MODULE	TV12 / 4-WAY / BLACK	SPARE WHEEL WELL
VEHICLE SPEED INTERFACE MODULE	TV14 / 8-WAY / BLACK EM74 / 42-WAY / BLUE	SPARE WHEEL WELL ENGINE COMPARTMENT / CONTROL MODULE ENCLOSURE

**HARNESSTO-HARNESSTO CONNECTORS**

Connector	Type / Color	Location / Access
EM2	20-WAY MULTILOCK 070 / YELLOW	ENGINE COMPARTMENT / ADJACENT TO RIGHT HAND ENCLOSURE
IC1	20-WAY MULTILOCK 070 / YELLOW	BELOW CENTER CONSOLE GLOVE BOX
IC2	14-WAY MULTILOCK 070 / WHITE	BELOW CENTER CONSOLE GLOVE BOX
IC3	14-WAY MULTILOCK 070 / GREY	BELOW CENTER CONSOLE GLOVE BOX
IC4	4-WAY MULTILOCK 070 / WHITE	TRUNK / LEFT OF ANTENNA ASSEMBLY

**GROUNDS**

Ground	Location / Type
BT2AR	EYELET (PAIR) - RIGHT HAND LEG / TRUNK, RIGHT REAR
EM1AL	EYELET (PAIR) - LEFT HAND LEG / ENGINE COMPARTMENT, RIGHT HAND ENCLOSURE
EM2AL	EYELET (PAIR) - LEFT HAND LEG / ENGINE COMPARTMENT, LEFT HAND ENCLOSURE
FC3BL	EYELET (PAIR) - LEFT HAND LEG / TRANSMISSION TUNNEL, LEFT HAND SIDE
TV36	EYELET (SINGLE) / BELOW PARCEL SHELF
TV37	EYELET (SINGLE) / LH REAR WHEEL ARCH
TV38	EYELET (SINGLE) / ADJACENT TO BATTERY

Refer to the front of this book for detailed information and illustrations regarding the location and identification of harnesses, relays, grounds, control modules and control module pins.

CONTROL MODULE PIN OUT INFORMATION

**Fig. 18.1**

**AIRBAG / SRS CONTROL MODULE**

Pin	Description	Active	Inactive
I FC29-4	GROUND	GROUND	GROUND
O FC29-5	MAJOR INSTRUMENT PACK AIRBAG MIL	GROUND	B+
D FC29-6	SERIAL COMMUNICATION		
I FC29-7	IGNITION SWITCHED POWER SUPPLY	B+	GROUND
I FC29-8	COMMON AIRBAG GROUND SUPPLY	GROUND (SHORTED IMPACT SENSOR)	OPEN CIRCUIT
I FC29-9	RH IMPACT SENSOR GROUND SUPPLY STATUS	GROUND (NO FAULT)	
I FC29-11	LH IMPACT SENSOR STATUS	GROUND (SHORTED)	B+
I FC29-12	RH IMPACT SENSOR STATUS	GROUND (SHORTED)	B+
O FC30-2	DRIVER SIDE AIRBAG POWER SUPPLY	B+ (SHORTED SAFING SENSOR)	OPEN CIRCUIT
O FC30-3	DRIVER SIDE AIRBAG GROUND SUPPLY	GROUND (SHORTED IMPACT SENSOR)	OPEN CIRCUIT
O FC30-4	PASSENGER SIDE AIRBAG GROUND SUPPLY	GROUND (SHORTED IMPACT SENSOR)	OPEN CIRCUIT
O FC30-5	PASSENGER SIDE AIRBAG POWER SUPPLY	B+ (SHORTED SAFING SENSOR)	OPEN CIRCUIT
I FC30-6	IGNITION SWITCHED POWER SUPPLY	B+	GROUND
O FC30-7	FUSED SUPPLY INTERRUPT	GROUND (FAULT PRESENT)	B+ (NO FAULT)
I FC30-8	DEPLOYMENT BATTERY POWER SUPPLY	B+	B+
I FC30-9	LH IMPACT SENSOR GROUND SUPPLY STATUS	0 V (NO FAULT)	
I FC30-10	COMMON AIRBAG GROUND SUPPLY	GROUND (SHORTED IMPACT SENSOR)	OPEN CIRCUIT
O FC30-11	CODE RETRIEVAL PULSED OUTPUT	GROUND (PULSED)	B+
I FC30-12	GROUND	GROUND	GROUND

**COMPONENTS**

Component	Connector / Type / Color	Location / Access
AIRBAG - DRIVER SIDE (STEERING WHEEL)	SW11 / 3-WAY EPC / BLACK	CENTER OF STEERING WHEEL
AIRBAG - PASSENGER SIDE	FC74 / 4-WAY MULTILOCK 070 / WHITE	LEFT HAND SIDE OF AIRBAG ASSEMBLY
AIRBAG INTERROGATION CONNECTOR	FC40 / 4-WAY MULTILOCK 070 / WHITE	RIGHT HAND 'A' POST / 'A' POST TRIM
AIRBAG / SRS CONTROL MODULE	FC29 / 12-WAY FORD CARD / BLACK FC30 / 12-WAY FORD CARD / GREY	RIGHT HAND 'A' POST / 'A' POST TRIM
IMPACT SENSOR - LH	LF50 / 4-WAY FORD CARD / NATURAL	FRONT UPPER CROSS MEMBER / FORWARD OF RADIATOR
IMPACT SENSOR - RH	LF51 / 4-WAY FORD CARD / NATURAL	FRONT UPPER CROSS MEMBER / FORWARD OF RADIATOR
PRE-TENSIONER CONTROL MODULE	FC1 / 30-WAY SIEMENS / YELLOW	BELOW CENTER CONSOLE ASSEMBLY
SEAT BELT PRE-TENSIONER - LH	PT2 / 2-WAY FORD AIRBAG / YELLOW	BEHIND LH REAR QUARTER TRIM PANEL
SEAT BELT PRE-TENSIONER - RH	PT3 / 2-WAY FORD AIRBAG / YELLOW	BEHIND LH REAR QUARTER TRIM PANEL

**HARNES-TO-HARNES CONNECTORS**

Connector	Type / Color	Location / Access
LF2	8-WAY FORD CARD / BLACK	LEFT HAND 'A' POST CONNECTOR MOUNTING BRACKET / 'A' POST TRIM
PT1	4-WAY MULTILOCK 070 / WHITE	BELOW CENTER CONSOLE ASSEMBLY
SW10	3-WAY EPC / BLACK	INSIDE STEERING COLUMN COWL

**GROUNDS**

Ground	Location / Type
FC1S	EYELET (SINGLE) / TRANSMISSION TUNNEL, RIGHT HAND SIDE

FOR CONTROL MODULE PIN OUT INFORMATION, UNFOLD PAGE TO LEFT.

Refer to the front of this book for detailed information and illustrations regarding the location and identification of harnesses, relays, grounds, control modules and control module pins.

CONTROL MODULE PIN OUT INFORMATION

**Fig. 19.1**

**BODY PROCESSOR MODULE**

Pin	Description	Active	Inactive
I	FC14-4	BATTERY POWER SUPPLY	B+
O	FC14-70	HORN RELAY ACTIVATE	B+
I	FC14-80	BATTERY POWER SUPPLY (LOGIC)	B+

**COMPONENTS**

Component	Connector / Type / Color	Location / Access
BODY PROCESSOR MODULE	FC14 / 104-WAY AMP EEEEC / GREY	PASSENGER SIDE FASCIA / AIRBAG BRACKET
CIGAR LIGHTER	FC42 / 2-WAY AMP / METALLIC FC59 / LUCAR POSILOCK / BLACK	FORWARD OF GEAR SELECTOR
FASCIA ACCESSORY CONNECTOR	FC51 / 3-WAY AMP SERIES 250 / BLACK	FASCIA / ADJACENT TO RIGHT HAND SIDE OF GLOVE BOX
FUSE BOX - ENGINE COMPARTMENT	LF5 / 10-WAY U.T.A. FUSEBOX / NATURAL LF6 / 10-WAY U.T.A. FUSEBOX / BLACK LF7 / 10-WAY U.T.A. FUSEBOX / GREEN LF8 / 10-WAY U.T.A. FUSEBOX / BLUE LF70 / EYELET	ENGINE COMPARTMENT / LEFT FRONT
FUSE BOX - TRUNK	BT10 / 10-WAY U.T.A. FUSEBOX / NATURAL BT11 / 10-WAY U.T.A. FUSEBOX / BLACK BT12 / 10-WAY U.T.A. FUSEBOX / GREEN BT13 / 10-WAY U.T.A. FUSEBOX / BLUE BT64 / EYELET	TRUNK / ELECTRICAL CARRIER
GARAGE DOOR OPENER (ROOF CONSOLE)	RF11 / HYBRID / WHITE RF10 / 6-WAY MULTILOCK 070 / GREY	ROOF CONSOLE
HORN SWITCHES (STEERING WHEEL)	HP1 / 1-WAY BLADE / METALLIC HP2 / 1-WAY BLADE / METALLIC HP3 / EYELET	CENTER OF STEERING WHEEL
HORN - LH	LF16 / LUCAR POSILOCK / BLACK LF17 / LUCAR POSILOCK / BLACK	FRONT BUMPER / REAR
HORN - RH	LF14 / LUCAR POSILOCK / BLACK LF15 / LUCAR POSILOCK / BLACK	FRONT BUMPER / REAR
TRUNK ACCESSORY CONNECTOR	BT25 / 3-WAY AMP SERIES 250 PIN / BLACK	TRUNK / ADJACENT TO BATTERY

**RELAYS**

Relay	Color / Stripe	Connector / Color	Location / Access
HORN RELAY (#6)	BROWN	BUS	ENGINE COMPARTMENT FUSE BOX
ACCESSORY CONNECTOR RELAY (#6)	BROWN	BUS	TRUNK FUSE BOX

**HARNESS-TO-HARNESS CONNECTORS**

Connector	Type / Color	Location / Access
BT58	4-WAY ECONOSEAL III HC / BLACK	TRUNK / ABOVE RIGHT HAND REAR WHEEL ARCH
LF60	20-WAY MULTILOCK 070 / WHITE	LEFT HAND 'A' POST CONNECTOR MOUNTING BRACKET / 'A' POST TRIM
RF1	18-WAY MULTILOCK 070 / YELLOW	RIGHT HAND 'A' POST CONNECTOR MOUNTING BRACKET / 'A' POST TRIM
RH14	2-WAY ECONOSEAL III HC / BLACK	REAR OF CENTER CONSOLE ASSEMBLY
SC2	10-WAY MULTILOCK 070 / YELLOW	ADJACENT TO STEERING COLUMN MOTOR
SC3	12-WAY MULTILOCK 070 / GREY	RIGHT HAND SIDE OF STEERING COLUMN
SW1	12-WAY MULTILOCK 040 / BLACK	INSIDE STEERING COLUMN COWL
SW2	6-WAY JST / WHITE	CENTER OF STEERING WHEEL

**GROUND**

Ground	Location / Type
BT2BR	EYELET (PAIR) - RIGHT HAND LEG / TRUNK, RIGHT REAR
BT2BS	EYELET (SINGLE) - TRUNK, RIGHT REAR
FC2BL	EYELET (PAIR) - LEFT HAND LEG / RIGHT HAND 'A' POST
FC2BR	EYELET (PAIR) - RIGHT HAND LEG / RIGHT HAND 'A' POST
FC3BL	EYELET (PAIR) - LEFT HAND LEG / TRANSMISSION TUNNEL, LEFT HAND SIDE
FC3BR	EYELET (PAIR) - RIGHT HAND LEG / TRANSMISSION TUNNEL, LEFT HAND SIDE
FC4BL	EYELET (PAIR) - LEFT HAND LEG / LEFT HAND 'A' POST
FC4BR	EYELET (PAIR) - RIGHT HAND LEG / LEFT HAND 'A' POST
LF1AL	EYELET (PAIR) - LEFT HAND LEG / RIGHT HAND HEADLAMP
LF2BR	EYELET (PAIR) - RIGHT HAND LEG / ENGINE COMPARTMENT, FORWARD OF LEFT HAND HOOD LATCH

FOR CONTROL MODULE PIN OUT INFORMATION, UNFOLD PAGE TO LEFT.

The following abbreviations are used to represent values for Control Module Pin-Out data

I	Input	D	Serial and Encoded Data	B+	Battery Voltage	kHz	Frequency x 1000
O	Output	C	CAN (Network)	V	Voltage (DC)	ms	Milliseconds
SG	Signal Ground	S	SCP Network	Hz	Frequency	mV	Millivolts

CAUTION: The information on this data page is furnished to aid the user in understanding circuit operation. THIS INFORMATION SHOULD BE USED FOR REFERENCE ONLY.

NOTE: The values listed are approximately those that can be expected at the control module connector pins with all circuit connections made and all components connected and fitted. "Active" means a load is applied or a switch is ON; "Inactive" means a load is not applied or a switch is OFF.

Refer to the front of this book for detailed information and illustrations regarding the location and identification of harnesses, relays, grounds, control modules and control module pins.



**Fig. 20.1**

**COMPONENTS**

Component	Connector / Type / Color	Location / Access
ABS / TRACTION CONTROL CONTROL MODULE	LF37 / 25-WAY AMP HYBRID / BLACK	ENGINE COMPARTMENT / FRONT LEFT
ACTIVE SECURITY SOUNDER	LF18 / 6-WAY ECONOSEAL III LC / BLACK	REARWARD OF RIGHT FRONT HEADLAMP
ADAPTIVE DAMPING CONTROL MODULE	BT69 / 35-WAY AMP / BLACK	TRUNK / ADJACENT TO ELECTRICAL CARRIER
AIR CONDITIONING CONTROL MODULE	AC1 / 26-WAY MULTILOCK 47 / GREY AC2 / 16-WAY MULTILOCK 47 / GREY AC3 / 12-WAY MULTILOCK 47 / GREY AC4 / 22-WAY MULTILOCK 47 / GREY	A/C UNIT / RIGHT HAND SIDE
AIRBAG / SRS CONTROL MODULE	FC29 / 12-WAY FORD CARD / BLACK FC30 / 12-WAY FORD CARD / GREY	RIGHT HAND 'A' POST / 'A' POST TRIM
BODY PROCESSOR MODULE	FC14 / 104-WAY AMP EEEEC / GREY	PASSENGER SIDE FASCIA / AIRBAG BRACKET
DATA LINK CONNECTOR	FC53 / 16-WAY AMP OBD2 / BLACK	BELOW DRIVER SIDE FUSE BOX
DOOR CONTROL MODULE - DRIVER	DD10 / 22-WAY FORD 2.8 TIMER / BLUE DD11 / 22-WAY FORD 2.8 TIMER / BLACK	DRIVER DOOR / DOOR CASING
DOOR CONTROL MODULE - PASSENGER	DP10 / 22-WAY FORD 2.8 TIMER / BLUE DP11 / 22-WAY FORD 2.8 TIMER / BLACK	PASSENGER DOOR / DOOR CASING
ENGINE CONTROL MODULE	EM80 / 31-WAY AMP 403 / NATURAL EM81 / 24-WAY AMP 403 / NATURAL EM82 / 17-WAY AMP 403 / NATURAL EM83 / 28-WAY AMP 403 / NATURAL EM84 / 22-WAY AMP 403 / NATURAL EM85 / 12-WAY MULTILOCK 070 / WHITE	ENGINE COMPARTMENT / CONTROL MODULE ENCLOSURE
GEAR SELECTOR ILLUMINATION MODULE	FC88 / 10-WAY MULTILOCK 070 / WHITE	FRONT OF GEAR SELECTOR ASSEMBLY
KEY TRANSPONDER MODULE	FC22 / 20-WAY MULTILOCK 040 / GREEN	ADJACENT TO DRIVER SIDE FUSE BOX
MAJOR INSTRUMENT PACK	FC25 / 26-WAY AMP MICRO QUAD LOCK / BLACK FC26 / 26-WAY AMP MICRO QUAD LOCK / YELLOW	FASCIA
SEAT CONTROL MODULE - DRIVER	SD3 / 16-WAY FORD 2.8 TIMER / BLACK SD4 / 26-WAY FORD IDC / BLACK SD5 / 10-WAY FORD 2.8 TIMER / BLACK	BELOW SEAT CUSHION
SEAT CONTROL MODULE - PASSENGER	SP3 / 16-WAY FORD 2.8 TIMER / BLACK SP5 / 10-WAY FORD 2.8 TIMER / BLACK	BELOW SEAT CUSHION
SECURITY AND LOCKING CONTROL MODULE	BT40 / 16-WAY FORD 2.8 TIMER / BLACK BT41 / 26-WAY FORD IDC / BLACK RH20 / COAXIAL CONNECTOR	TRUNK / ELECTRICAL CARRIER
TRANSMISSION CONTROL MODULE	EM7 / 88-WAY BOSCH / BLACK	ENGINE COMPARTMENT / CONTROL MODULE ENCLOSURE
VEHICLE SPEED INTERFACE MODULE	EM74 / 42-WAY / BLUE	ENGINE COMPARTMENT / CONTROL MODULE ENCLOSURE

**HARNESSTO-HARNESSTO CONNECTORS**

Connector	Type / Color	Location / Access
AC14	14-WAY MULTILOCK 070 / GREY	FASCIA BOTTOM CONNECTOR MOUNTING BRACKET / RIGHT HAND SIDE
BT1	20-WAY MULTILOCK 070 / WHITE	TRUNK / ABOVE RIGHT HAND REAR WHEEL ARCH
BT2	20-WAY MULTILOCK 070 / WHITE	TRUNK / ABOVE RIGHT HAND REAR WHEEL
DD1	23-WAY AMP - FORD / BLACK	DRIVER SIDE 'A' POST MOUNTING BRACKET / 'A' POST TRIM
DP1	23-WAY AMP - FORD / BLACK	PASSENGER SIDE 'A' POST / 'A' POST TRIM
EM1	20-WAY MULTILOCK 070 / WHITE	ENGINE COMPARTMENT / ADJACENT TO RIGHT HAND ENCLOSURE
LF1	20-WAY MULTILOCK 070 / GREY	LEFT HAND 'A' POST CONNECTOR MOUNTING BRACKET / 'A' POST TRIM
LF40	13-WAY ECONOSEAL III LC / BLACK	ENGINE COMPARTMENT / LEFT HAND ENCLOSURE
RH2	20-WAY MULTILOCK 070 / WHITE	REAR OF CENTER CONSOLE ASSEMBLY
RH12	18-WAY MULTILOCK 070 / YELLOW	REAR OF CENTER CONSOLE ASSEMBLY
SD1	8-WAY MULTILOCK 070 / YELLOW	BELOW DRIVER SEAT
SP1	8-WAY MULTILOCK 070 / YELLOW	BELOW PASSENGER SEAT

**GROUNDS**

Ground	Location / Type
FC3BL	EYELET (PAIR) - LEFT HAND LEG / TRANSMISSION TUNNEL, LEFT HAND SIDE

**NOTE:** Refer to the Appendix at the rear of this book for CAN and SCP Network Messages.

Refer to the front of this book for detailed information and illustrations regarding the location and identification of harnesses, relays, grounds, control modules and control module pins.

**Fig. 20.2**

**COMPONENTS**

Component	Connector / Type / Color	Location / Access
ABS / TRACTION CONTROL CONTROL MODULE	LF37 / 25-WAY AMP HYBRID / BLACK	ENGINE COMPARTMENT / FRONT LEFT
ACTIVE SECURITY SOUNDER	LF18 / 6-WAY ECONOSEAL III LC / BLACK	REARWARD OF RIGHT FRONT HEADLAMP
ADAPTIVE DAMPING CONTROL MODULE	BT69 / 35-WAY AMP / BLACK	TRUNK / ADJACENT TO ELECTRICAL CARRIER
ADAPTIVE SPEED CONTROL BOOSTER CONTROL MODULE	AL4 / 16-WAY / BLACK	ENGINE COMPARTMENT / CONTROL MODULE ENCLOSURE
ADAPTIVE SPEED CONTROL CONTROL MODULE	EM87 / 10-WAY AMP JUNIOR POWER TIMER / BLACK	ENGINE COMPARTMENT / FORWARD OF RADIATOR
AIR CONDITIONING CONTROL MODULE	LF61 / 24-WAY DELPHI MICROPACK 100W SERIES / BLACK	A/C UNIT / RIGHT HAND SIDE
	AC1 / 26-WAY MULTILOCK 47 / GREY	
	AC2 / 16-WAY MULTILOCK 47 / GREY	
	AC3 / 12-WAY MULTILOCK 47 / GREY	
	AC4 / 22-WAY MULTILOCK 47 / GREY	
AIRBAG / SRS CONTROL MODULE	FC29 / 12-WAY FORD CARD / BLACK	RIGHT HAND 'A' POST / 'A' POST TRIM
	FC30 / 12-WAY FORD CARD / GREY	
BODY PROCESSOR MODULE	FC14 / 104-WAY AMP EEEEC / GREY	PASSENGER SIDE FASCIA / AIRBAG BRACKET
DATA LINK CONNECTOR	FC53 / 16-WAY AMP OBD2 / BLACK	BELOW DRIVER SIDE FUSE BOX
DOOR CONTROL MODULE - DRIVER	DD10 / 22-WAY FORD 2.8 TIMER / BLUE	DRIVER DOOR / DOOR CASING
	DD11 / 22-WAY FORD 2.8 TIMER / BLACK	
DOOR CONTROL MODULE - PASSENGER	DP10 / 22-WAY FORD 2.8 TIMER / BLUE	PASSENGER DOOR / DOOR CASING
	DP11 / 22-WAY FORD 2.8 TIMER / BLACK	
ENGINE CONTROL MODULE	EM80 / 31-WAY AMP 403 / NATURAL	ENGINE COMPARTMENT / CONTROL MODULE ENCLOSURE
	EM81 / 24-WAY AMP 403 / NATURAL	
	EM82 / 17-WAY AMP 403 / NATURAL	
	EM83 / 28-WAY AMP 403 / NATURAL	
	EM84 / 22-WAY AMP 403 / NATURAL	
	EM85 / 12-WAY MULTILOCK 070 / WHITE	
GEAR SELECTOR ILLUMINATION MODULE	FC88 / 10-WAY MULTILOCK 070 / WHITE	FRONT OF GEAR SELECTOR ASSEMBLY
KEY TRANSPONDER MODULE	FC22 / 20-WAY MULTILOCK 040 / GREEN	ADJACENT TO DRIVER SIDE FUSE BOX
MAJOR INSTRUMENT PACK	FC25 / 26-WAY AMP MICRO QUAD LOCK / BLACK	FASCIA
	FC26 / 26-WAY AMP MICRO QUAD LOCK / YELLOW	
SEAT CONTROL MODULE - DRIVER	SD3 / 16-WAY FORD 2.8 TIMER / BLACK	BELOW SEAT CUSHION
	SD4 / 26-WAY FORD IDC / BLACK	
	SD5 / 10-WAY FORD 2.8 TIMER / BLACK	
SEAT CONTROL MODULE - PASSENGER	SP3 / 16-WAY FORD 2.8 TIMER / BLACK	BELOW SEAT CUSHION
	SP5 / 10-WAY FORD 2.8 TIMER / BLACK	
SECURITY AND LOCKING CONTROL MODULE	BT40 / 16-WAY FORD 2.8 TIMER / BLACK	TRUNK / ELECTRICAL CARRIER
	BT41 / 26-WAY FORD IDC / BLACK	
	RH20 / COAXIAL CONNECTOR	
TRANSMISSION CONTROL MODULE	EM72 / 14-WAY AMP JUNIOR POWER TIMER / BLACK	ENGINE COMPARTMENT / CONTROL MODULE ENCLOSURE
	EM73 / 18-WAY AMP JUNIOR POWER TIMER / BLACK	
VEHICLE SPEED INTERFACE MODULE	EM74 / 42-WAY / BLUE	ENGINE COMPARTMENT / CONTROL MODULE ENCLOSURE

**HARNESSTO-HARNESSTO CONNECTORS**

Connector	Type / Color	Location / Access
AC14	14-WAY MULTILOCK 070 / GREY	FASCIA BOTTOM CONNECTOR MOUNTING BRACKET / RIGHT HAND SIDE
BT1	20-WAY MULTILOCK 070 / WHITE	TRUNK / ABOVE RIGHT HAND REAR WHEEL ARCH
BT2	20-WAY MULTILOCK 070 / WHITE	TRUNK / ABOVE RIGHT HAND REAR WHEEL
DD1	23-WAY AMP - FORD / BLACK	DRIVER SIDE 'A' POST MOUNTING BRACKET / 'A' POST TRIM
DP1	23-WAY AMP - FORD / BLACK	PASSENGER SIDE 'A' POST / 'A' POST TRIM
EM1	20-WAY MULTILOCK 070 / WHITE	ENGINE COMPARTMENT / ADJACENT TO RIGHT HAND ENCLOSURE
LF1	20-WAY MULTILOCK 070 / GREY	LEFT HAND 'A' POST CONNECTOR MOUNTING BRACKET / 'A' POST TRIM
LF40	13-WAY ECONOSEAL III LC / BLACK	ENGINE COMPARTMENT / LEFT HAND ENCLOSURE
RH2	20-WAY MULTILOCK 070 / WHITE	REAR OF CENTER CONSOLE ASSEMBLY
RH12	18-WAY MULTILOCK 070 / YELLOW	REAR OF CENTER CONSOLE ASSEMBLY
SD1	8-WAY MULTILOCK 070 / YELLOW	BELOW DRIVER SEAT
SP1	8-WAY MULTILOCK 070 / YELLOW	BELOW PASSENGER SEAT

**GROUNDS**

Ground	Location / Type
FC3BL	EYELET (PAIR) - LEFT HAND LEG / TRANSMISSION TUNNEL, LEFT HAND SIDE

**NOTE:** Refer to the Appendix at the rear of this book for CAN and SCP Network Messages.

Refer to the front of this book for detailed information and illustrations regarding the location and identification of harnesses, relays, grounds, control modules and control module pins.

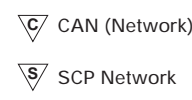
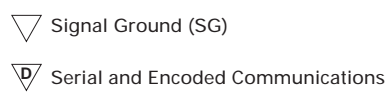
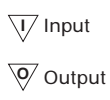
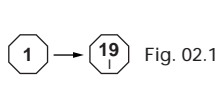
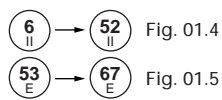
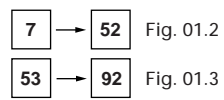
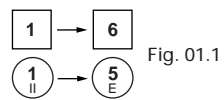
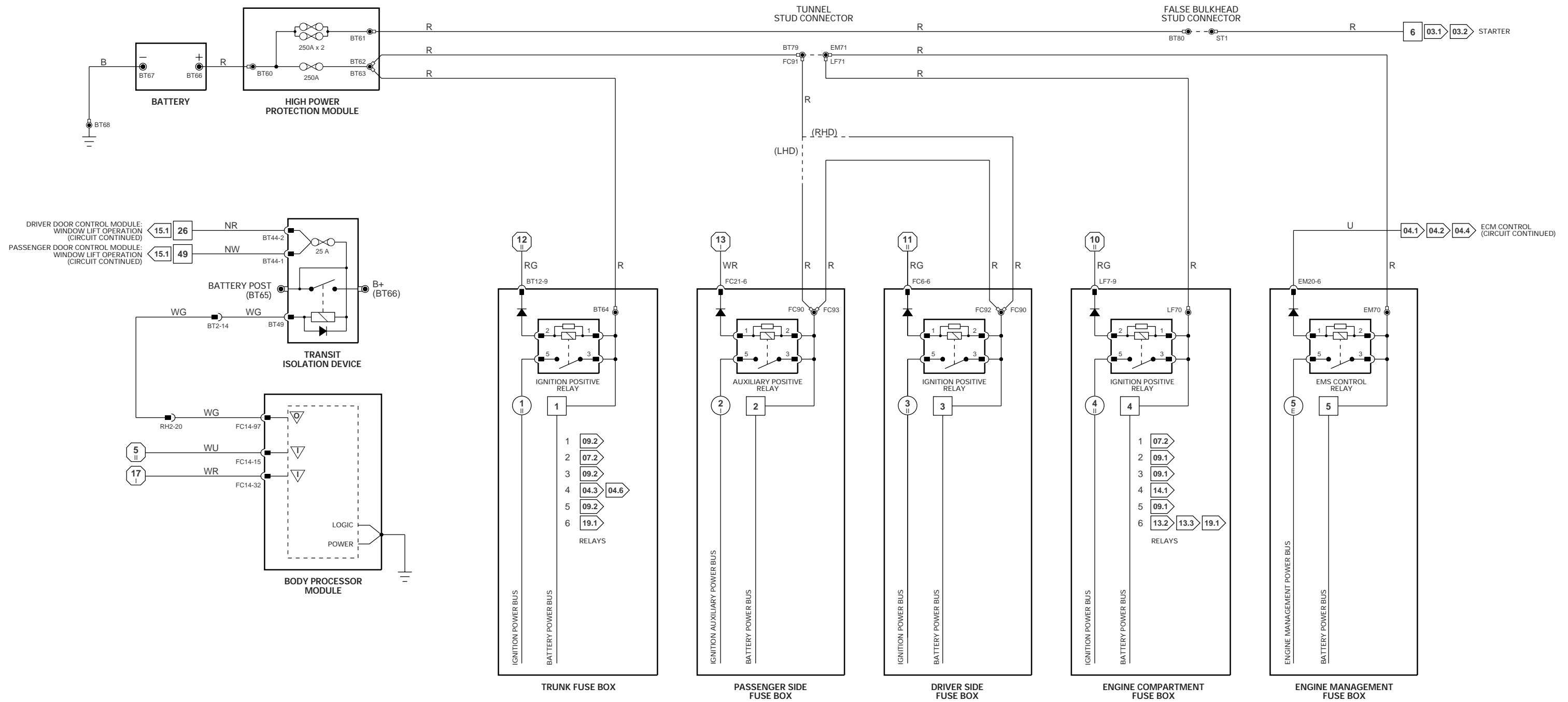

VARIANT: All Vehicles  
 VIN RANGE: A00116 →  
 DATE OF ISSUE: September 1999

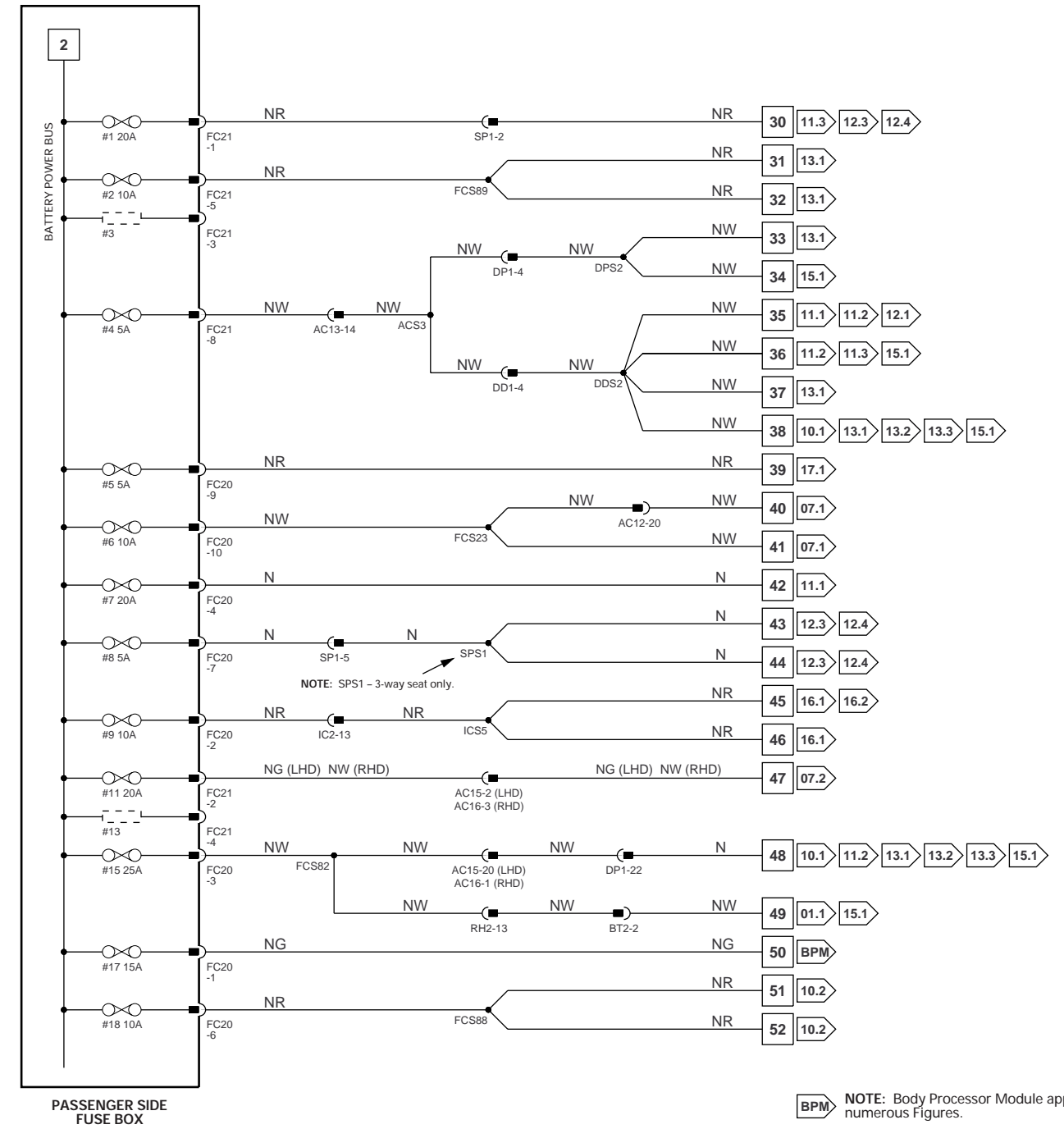
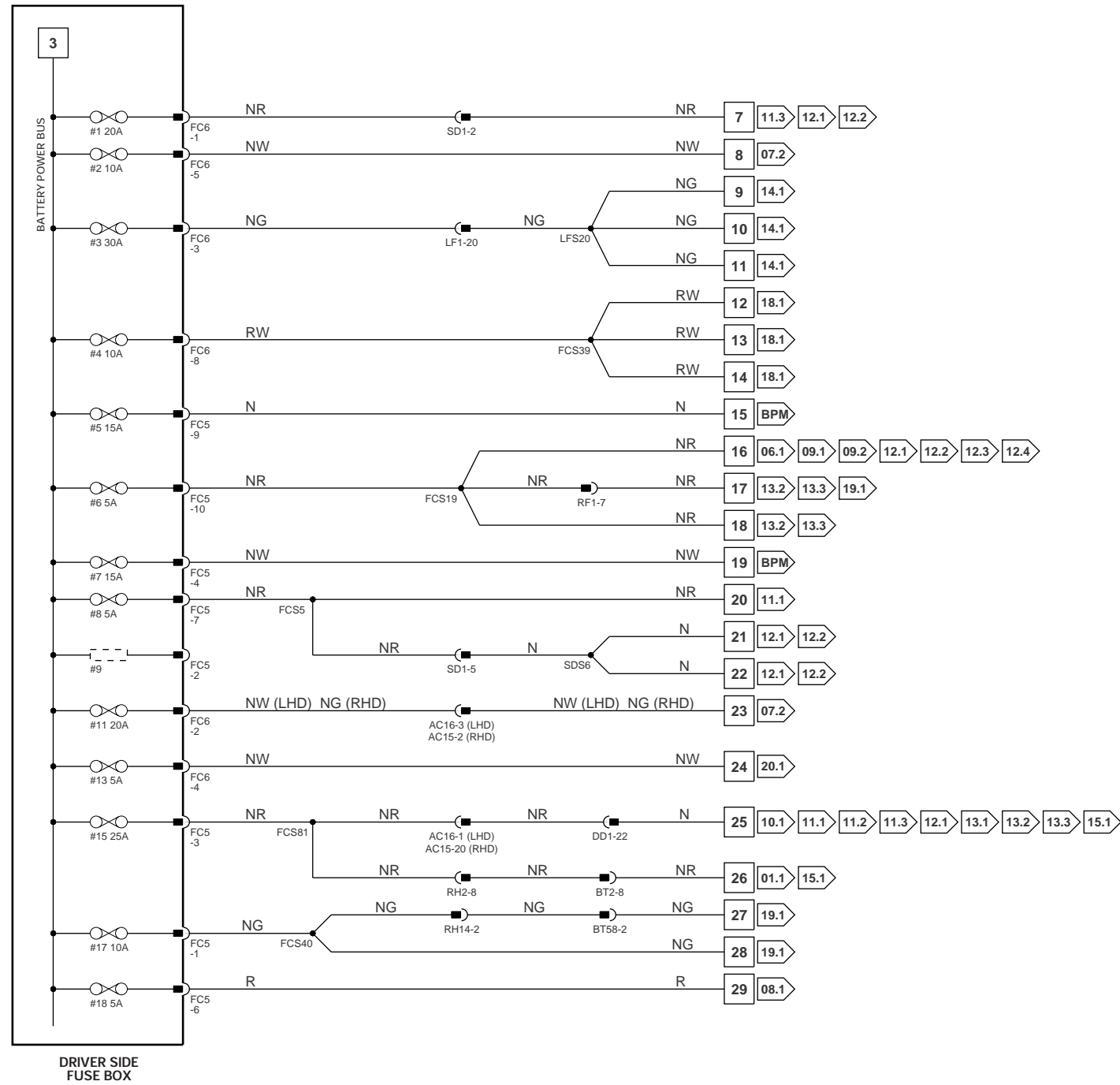

**BPM** NOTE: Body Processor Module appears in numerous Figures.

Fig. 01.1	Fig. 01.2	Fig. 01.4	Fig. 02.1			
Fig. 01.3	Fig. 01.5	Fig. 01.5				

**VARIANT:** All Vehicles  
**VIN RANGE:** A00116 →  
**DATE OF ISSUE:** September 1999

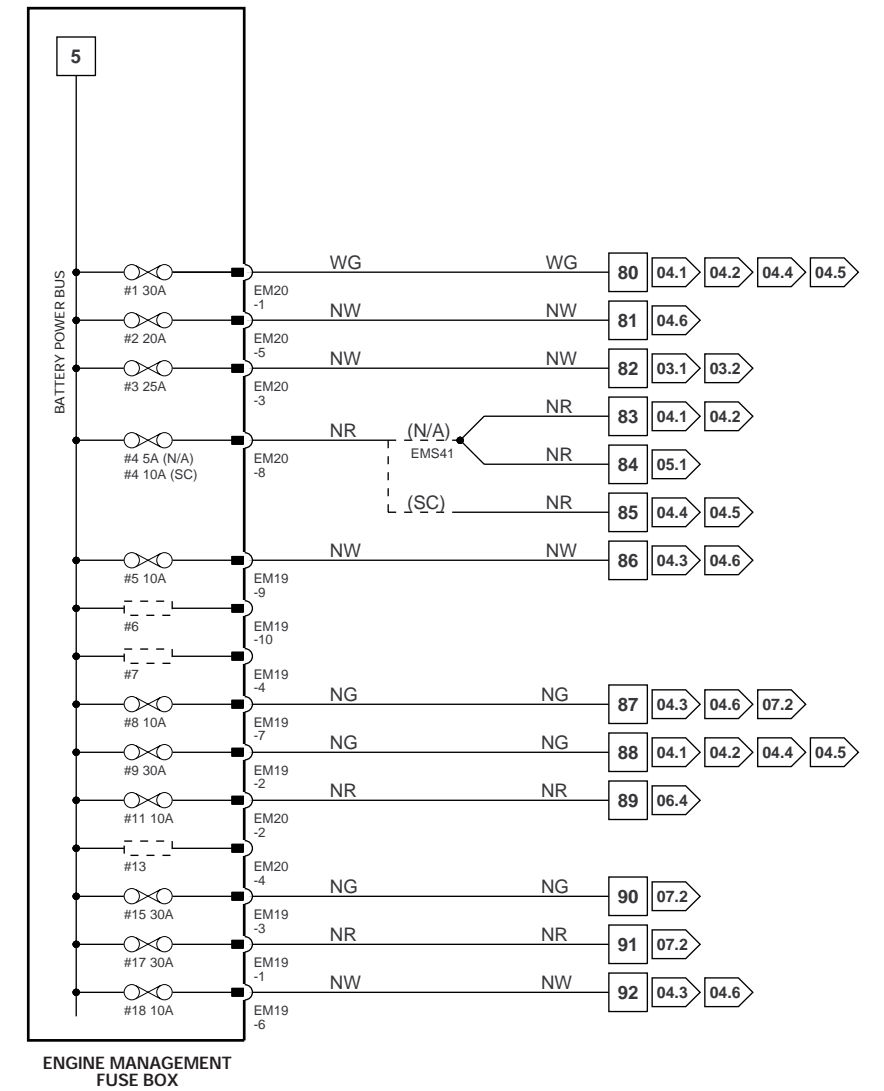
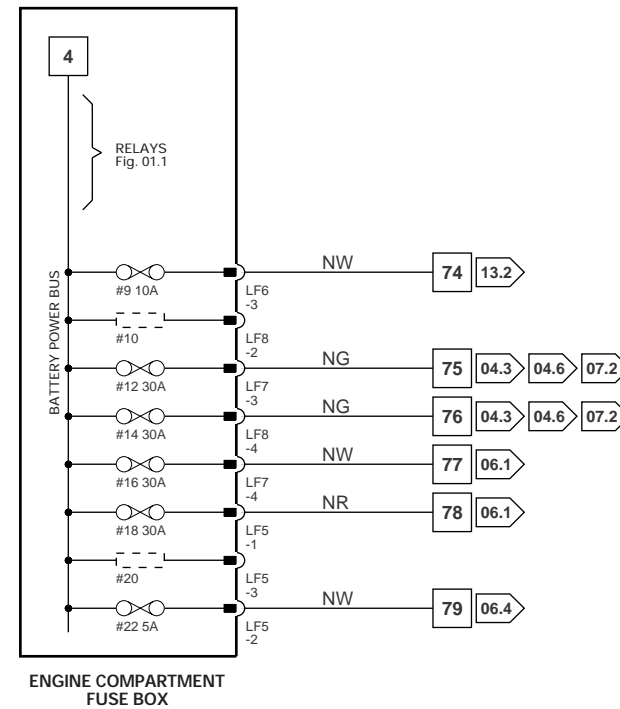
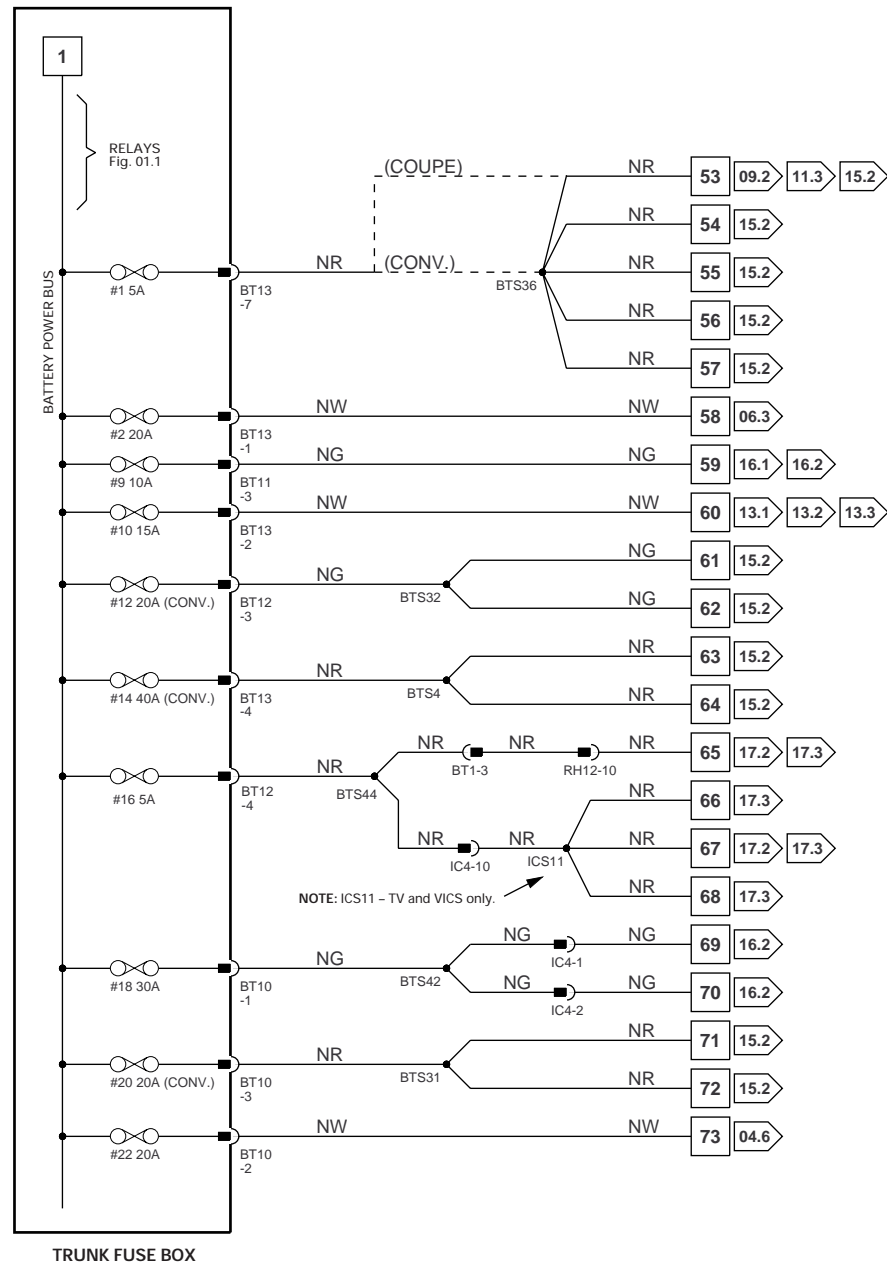

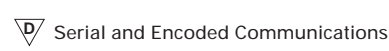
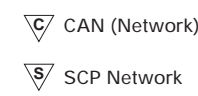
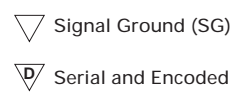
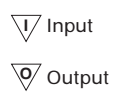
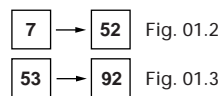
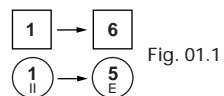
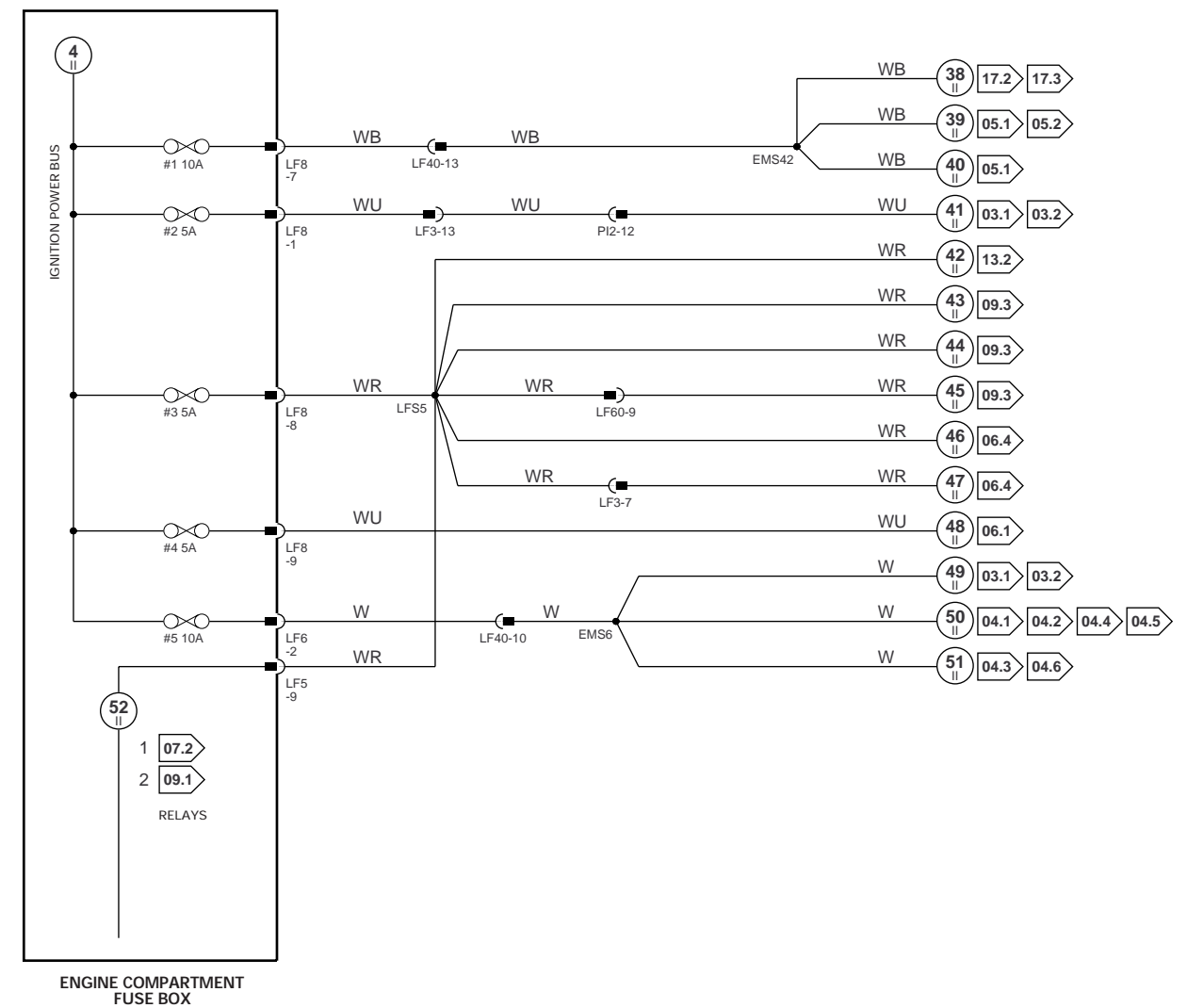
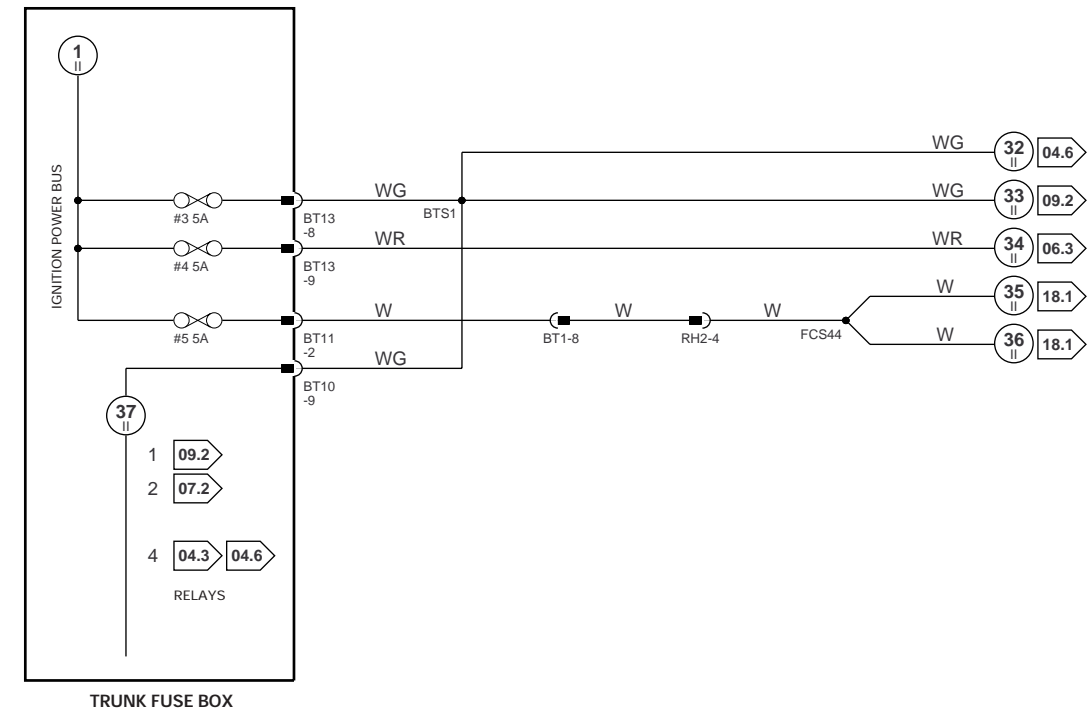
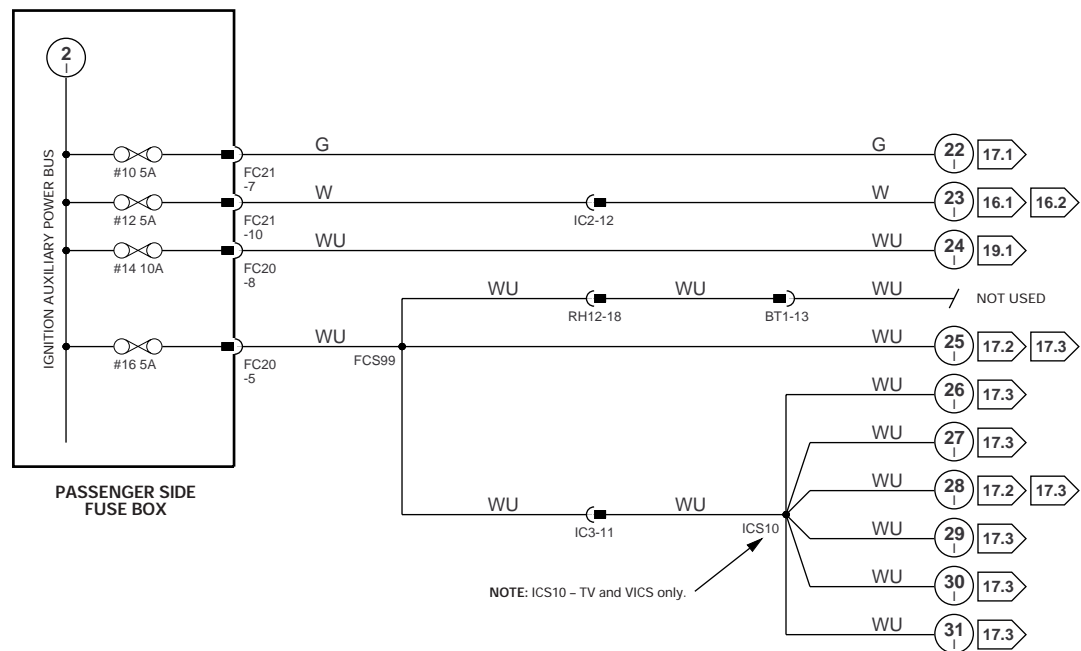
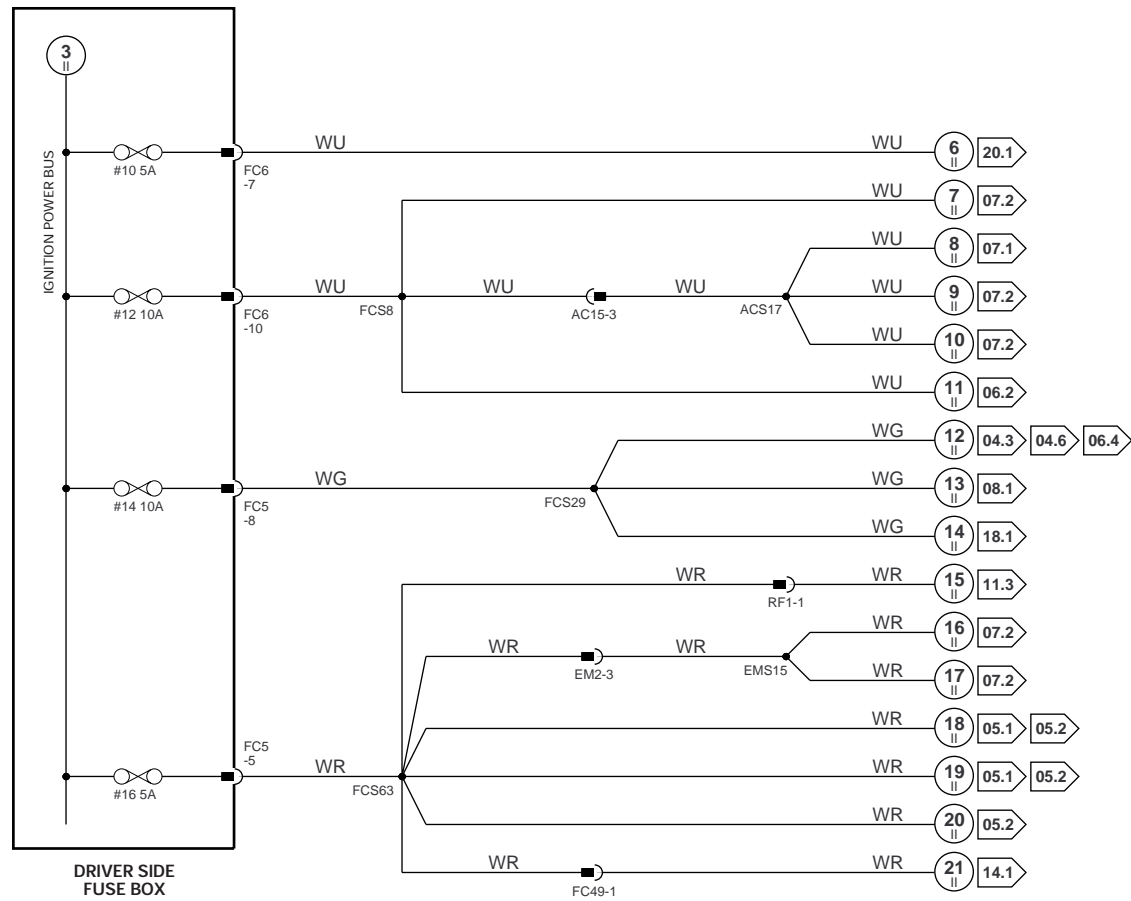

VARIANT: All Vehicles  
VIN RANGE: A00116 →  
DATE OF ISSUE: September 1999

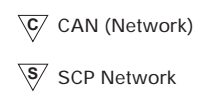
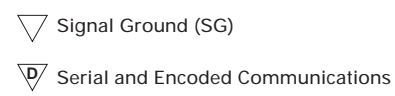
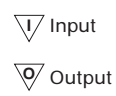
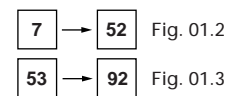
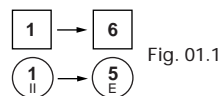
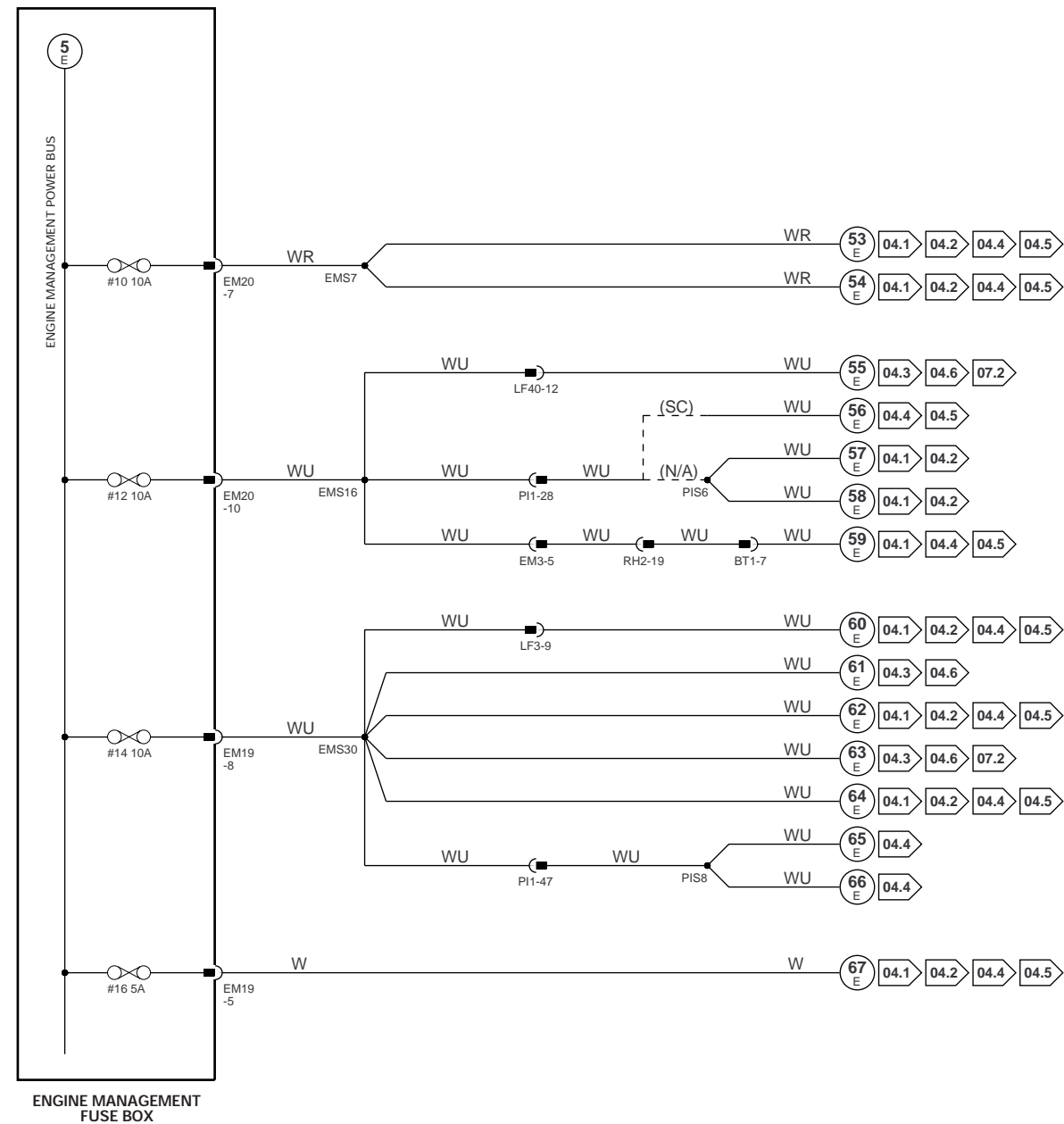

VARIANT: All Vehicles  
 VIN RANGE: A00116 →  
 DATE OF ISSUE: September 1999

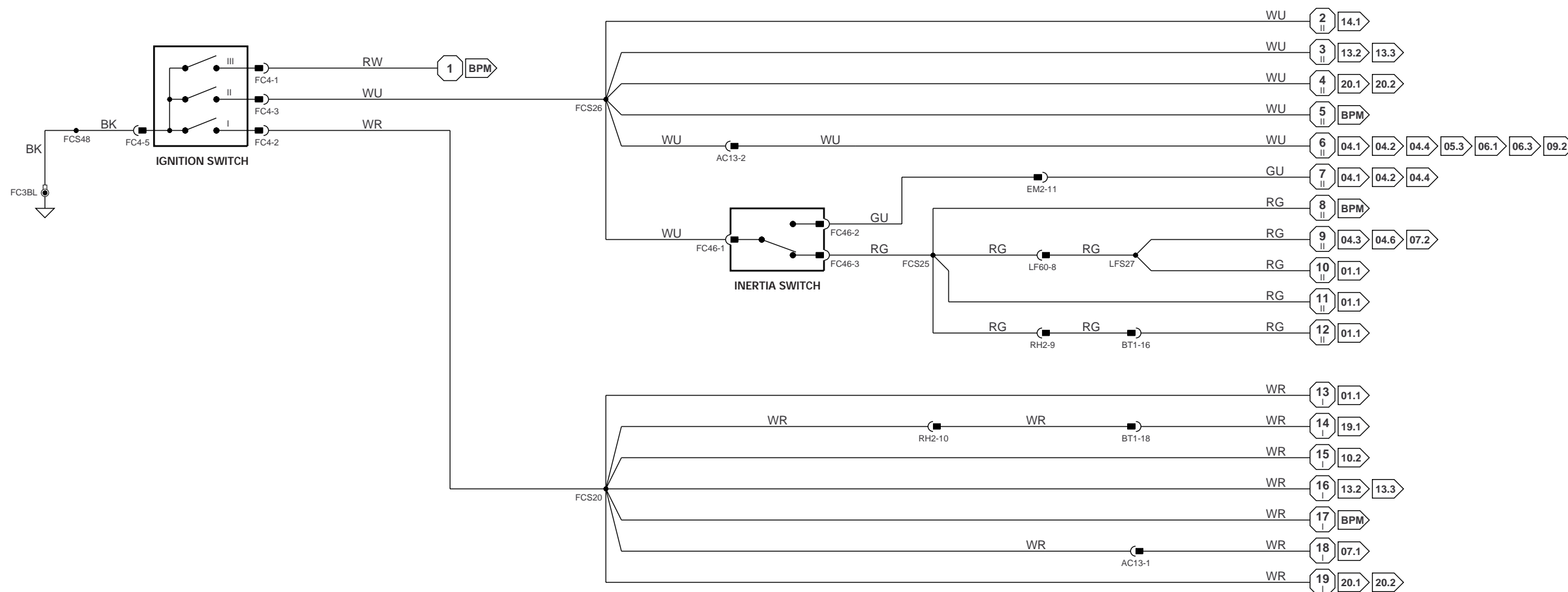
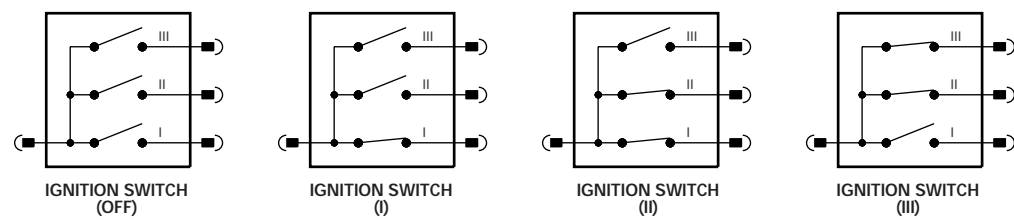

**BPM** NOTE: Body Processor Module appears in numerous Figures.

<p>1 → 6 Fig. 01.1    7 → 52 Fig. 01.2    6 → 52 Fig. 01.4    1 → 19 Fig. 02.1</p> <p>1 → 5 Fig. 01.1    53 → 92 Fig. 01.3    53 → 67 Fig. 01.5</p>	<p>▽ Input    ▽ Signal Ground (SG)    ▽ CAN (Network)</p> <p>○ Output    ▽ Serial and Encoded Communications    ▽ SCP Network</p>	<p>VARIANT: All Vehicles VIN RANGE: A00116 → DATE OF ISSUE: September 1999</p>
---	---	--



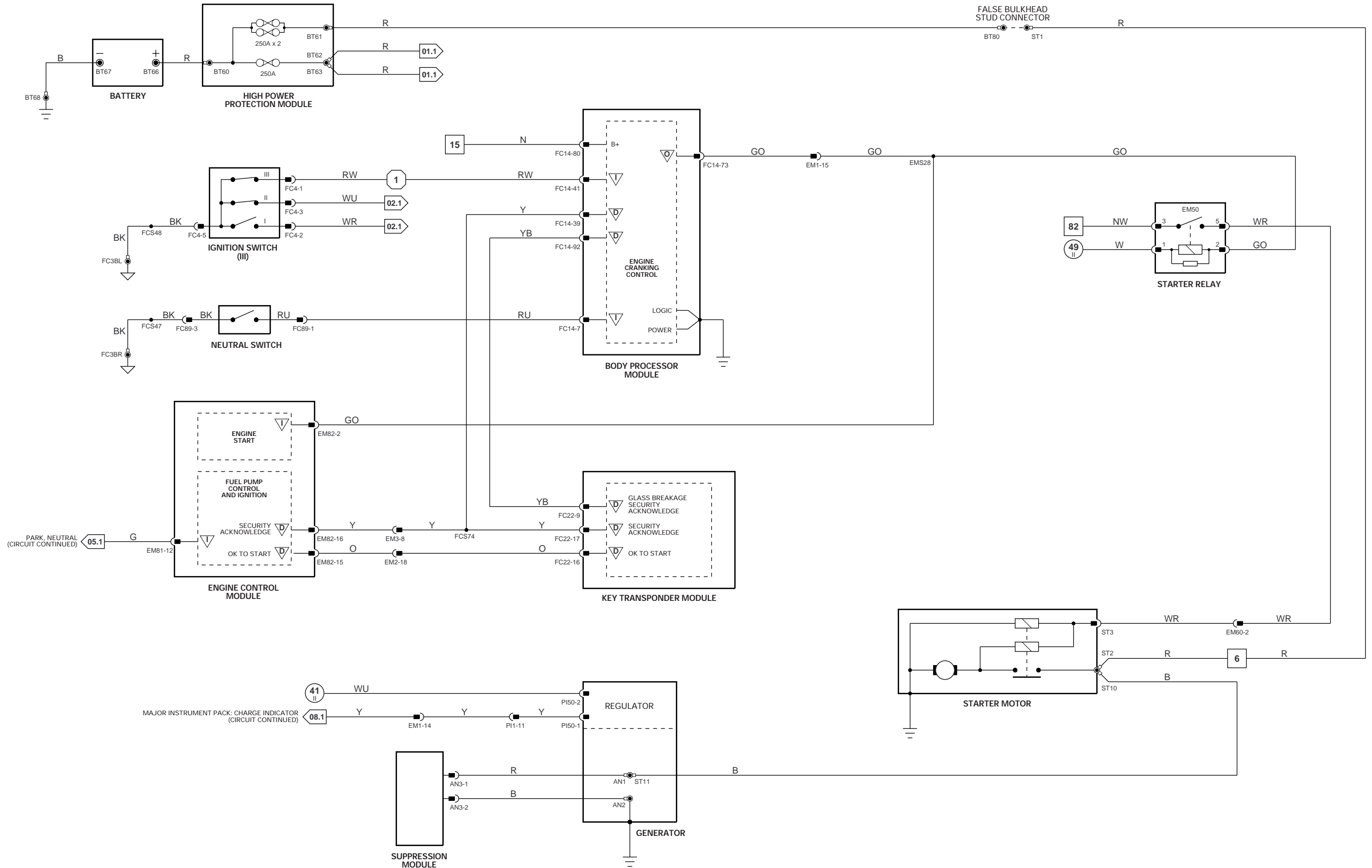

VARIANT: AJ27 N/A Vehicles  
 VIN RANGE: A00116 →  
 DATE OF ISSUE: September 1999

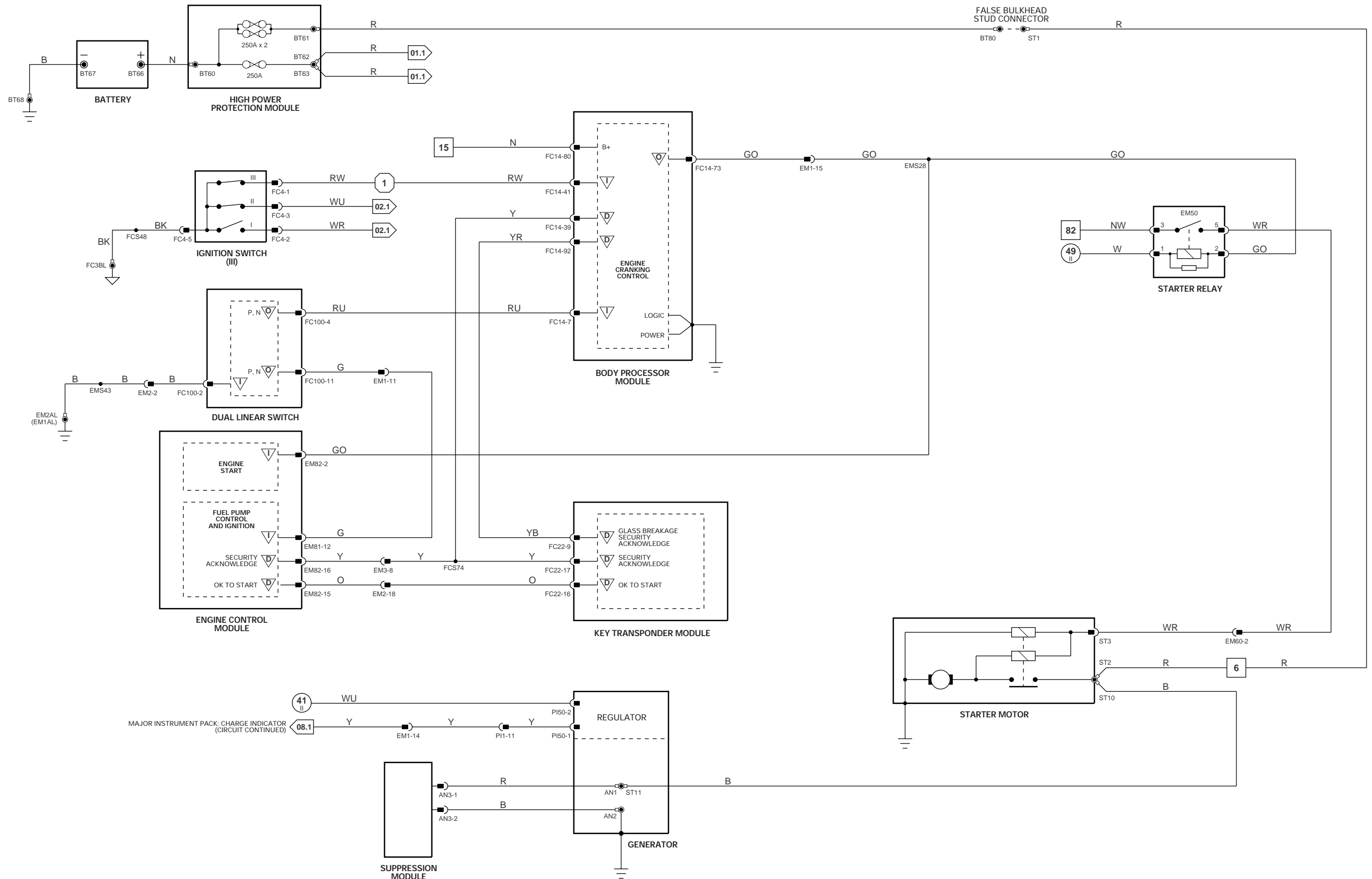

VARIANT: AJ27 SC Vehicles  
 VIN RANGE: A00116 →  
 DATE OF ISSUE: September 1999

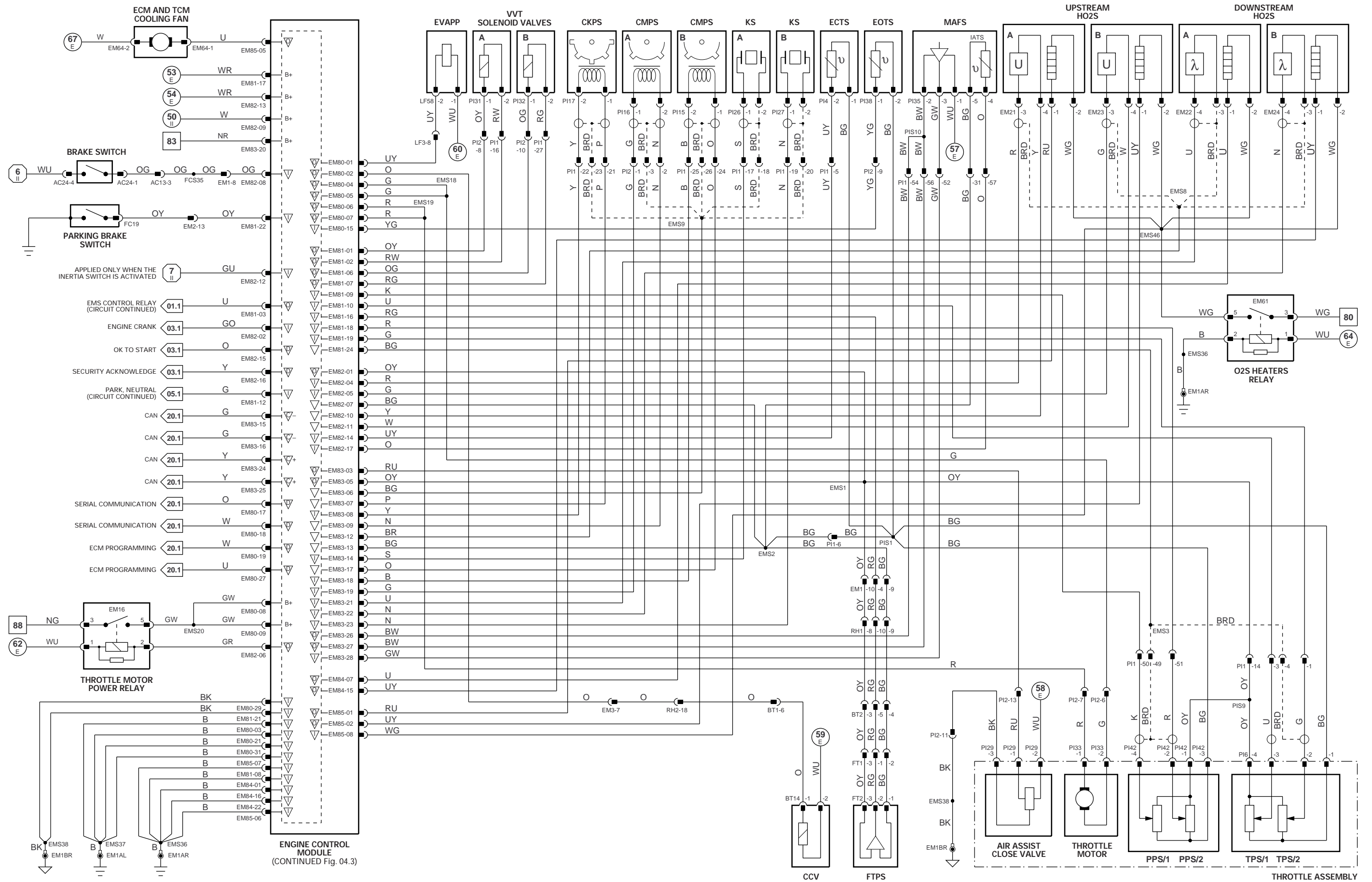

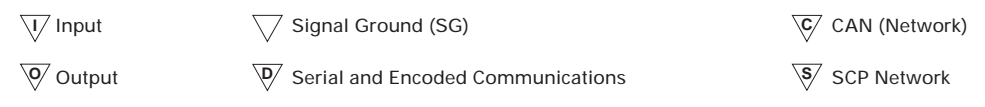
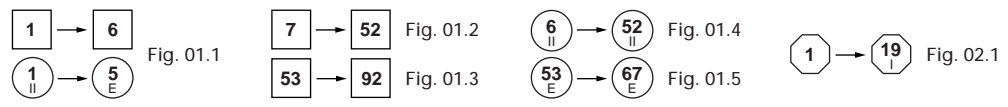
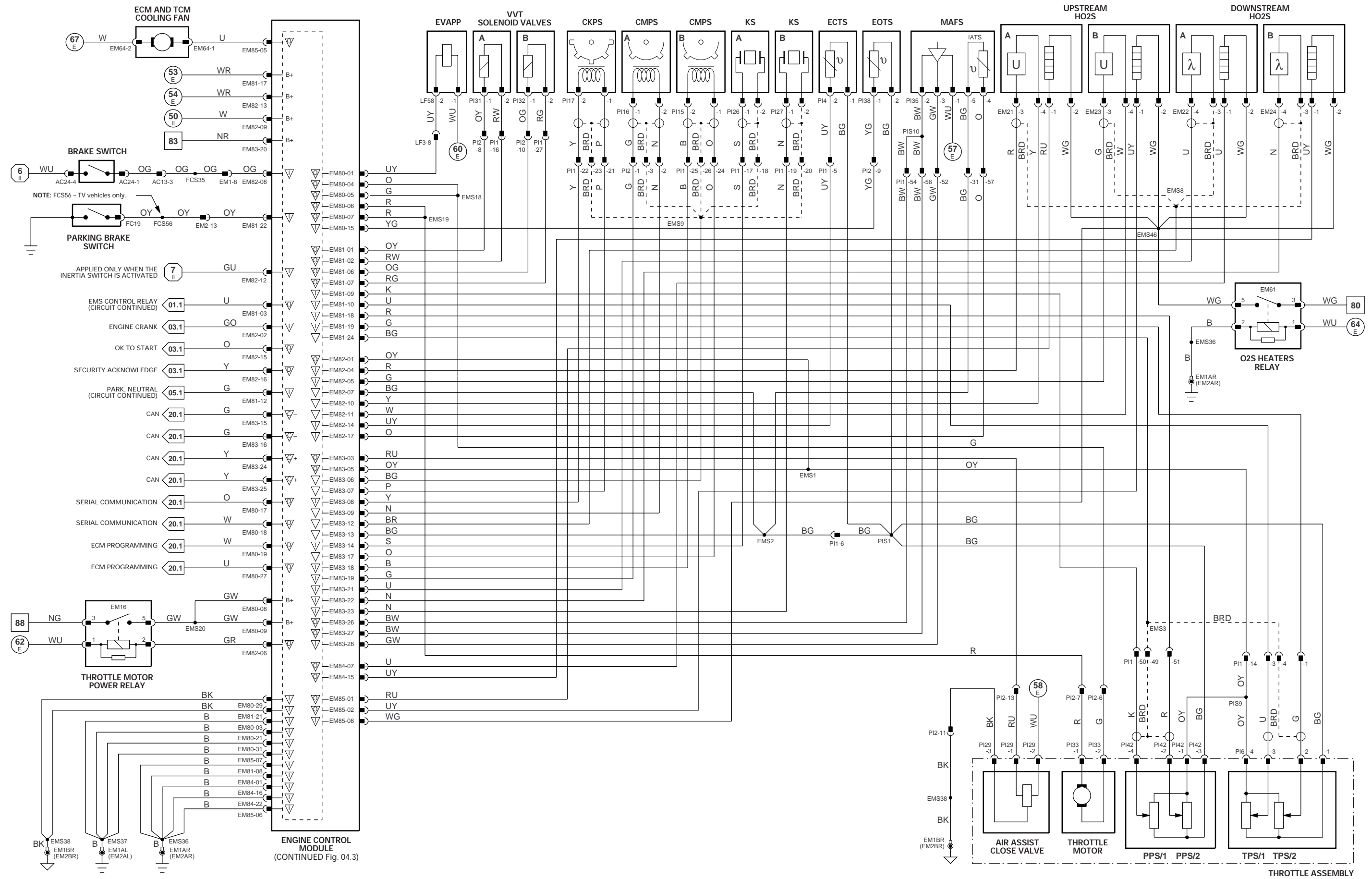

VARIANT: AJ27 N/A ROW Vehicles  
 VIN RANGE: A00116 →  
 DATE OF ISSUE: September 1999

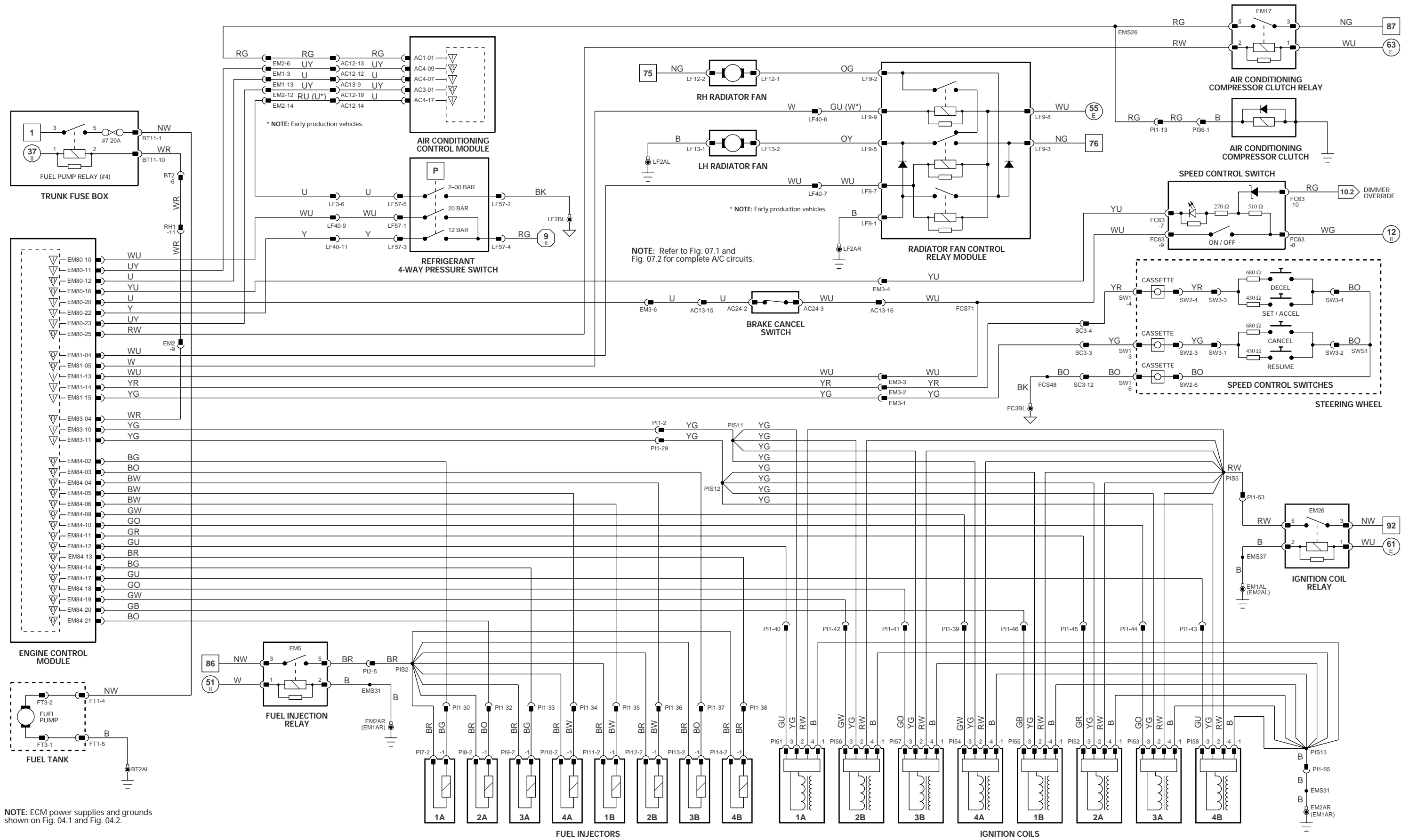

NOTE: ECM power supplies and grounds shown on Fig. 04.1 and Fig. 04.2.

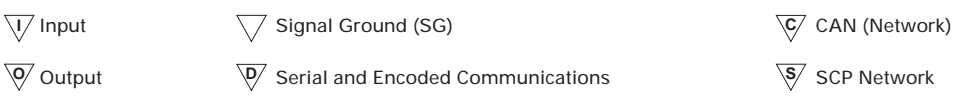
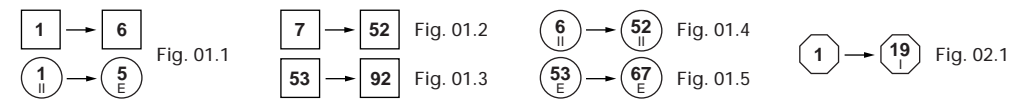

VARIANT: AJ27 N/A Vehicles  
 VIN RANGE: A00116 →  
 DATE OF ISSUE: September 1999

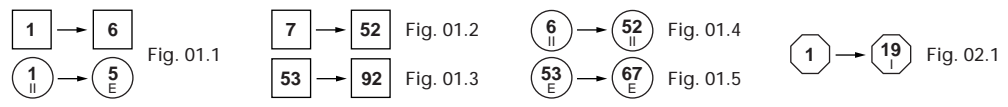
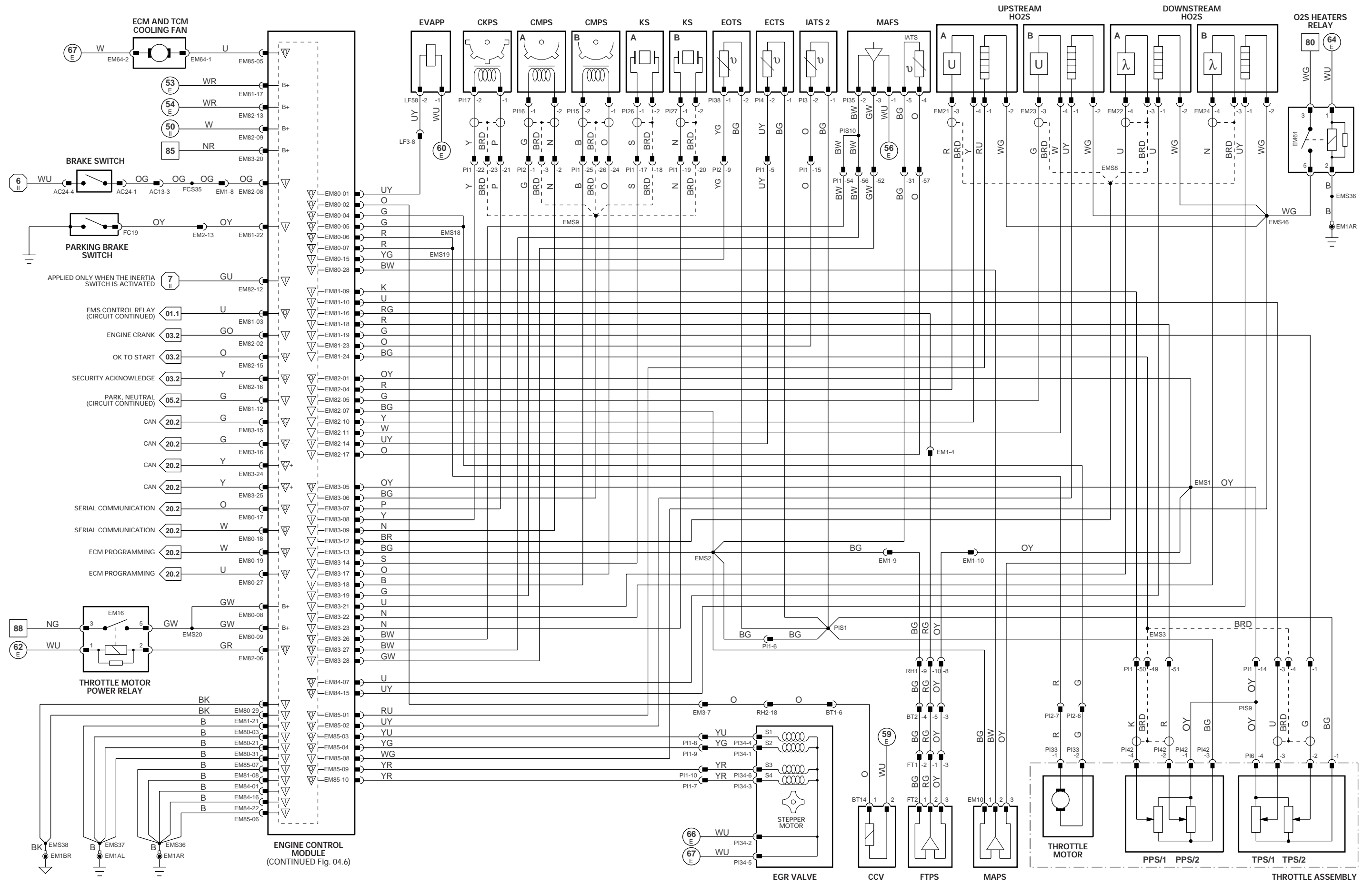

VARIANT: AJ27 SC NAS Vehicles  
 VIN RANGE: A00116 →  
 DATE OF ISSUE: September 1999

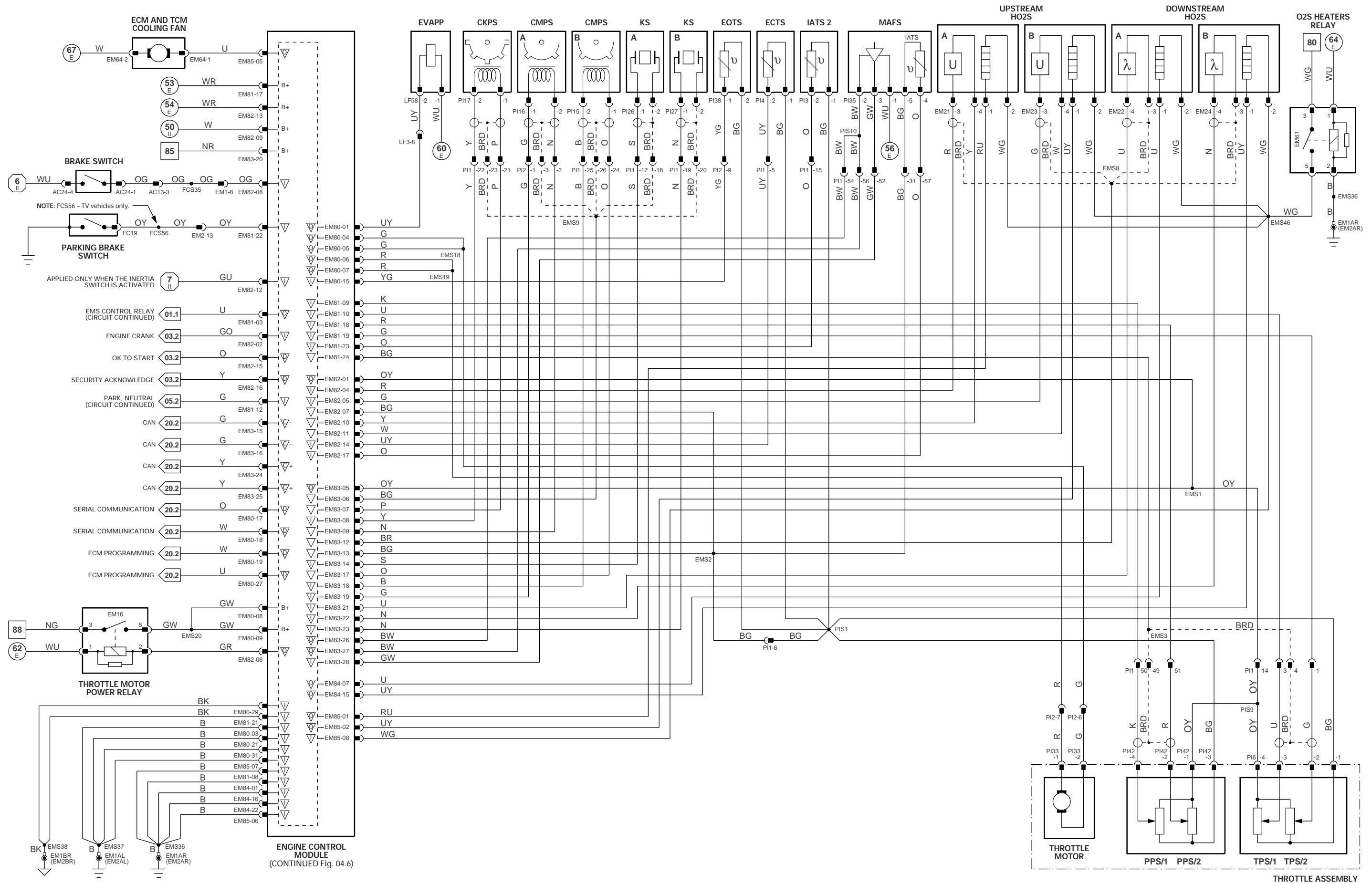

VARIANT: AJ27 SC ROW Vehicles  
 VIN RANGE: A00116 →  
 DATE OF ISSUE: September 1999

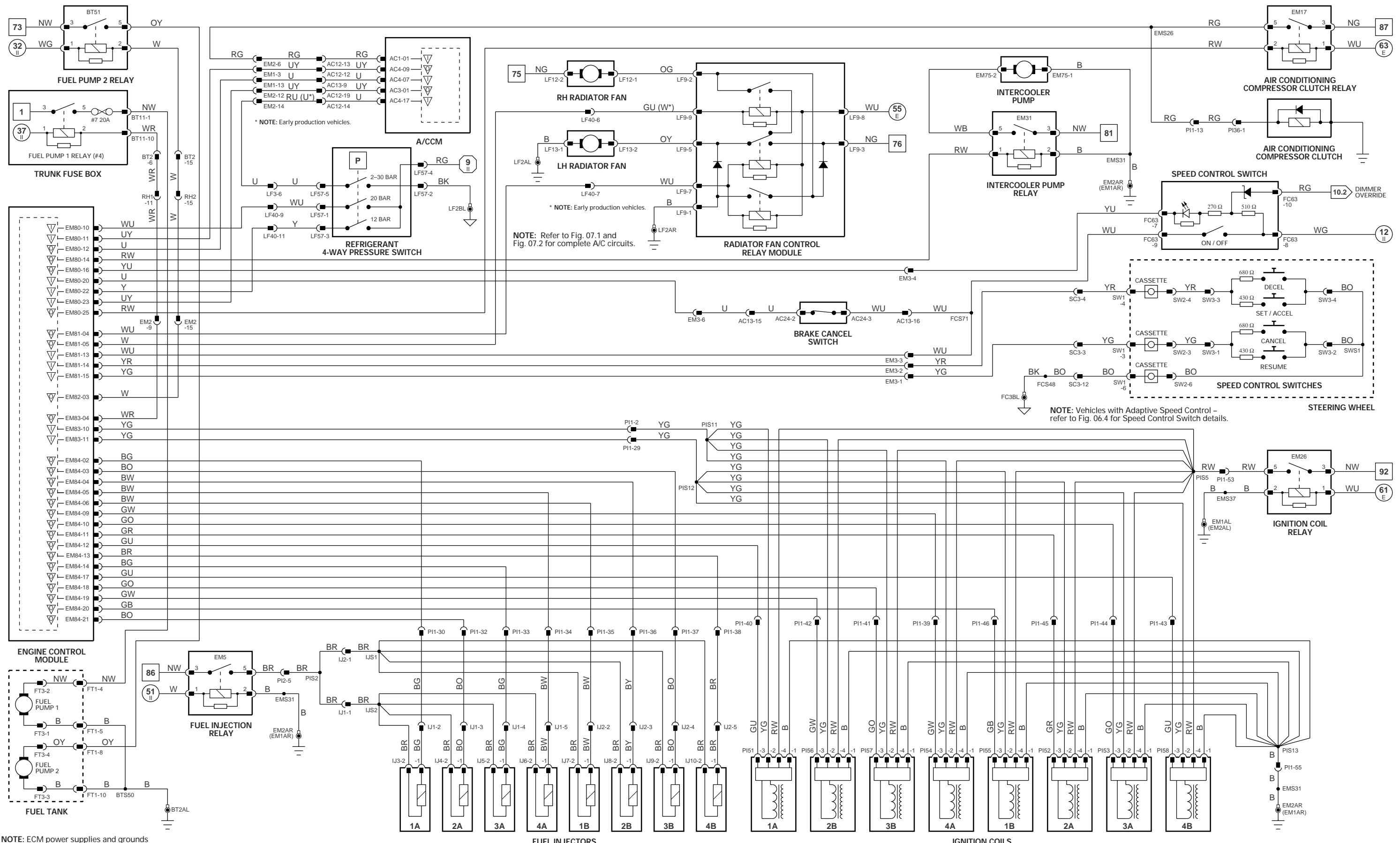

NOTE: ECM power supplies and grounds shown on Fig. 04.4 and Fig. 04.5.

NOTE: Vehicles with Adaptive Speed Control - refer to Fig. 06.4 for Speed Control Switch details.

	Fig. 01.1		Fig. 01.2		Fig. 01.4		Fig. 02.1		Input		Signal Ground (SG)		CAN (Network)
	Fig. 01.3		Fig. 01.5		Fig. 01.5				Output		Serial and Encoded Communications		SCP Network

VARIANT: AJ27 SC Vehicles  
 VIN RANGE: A00116 →  
 DATE OF ISSUE: September 1999





NOTE: Gear Selector Illumination Module – CAN 'Listen only' node for gear selector position indicators.

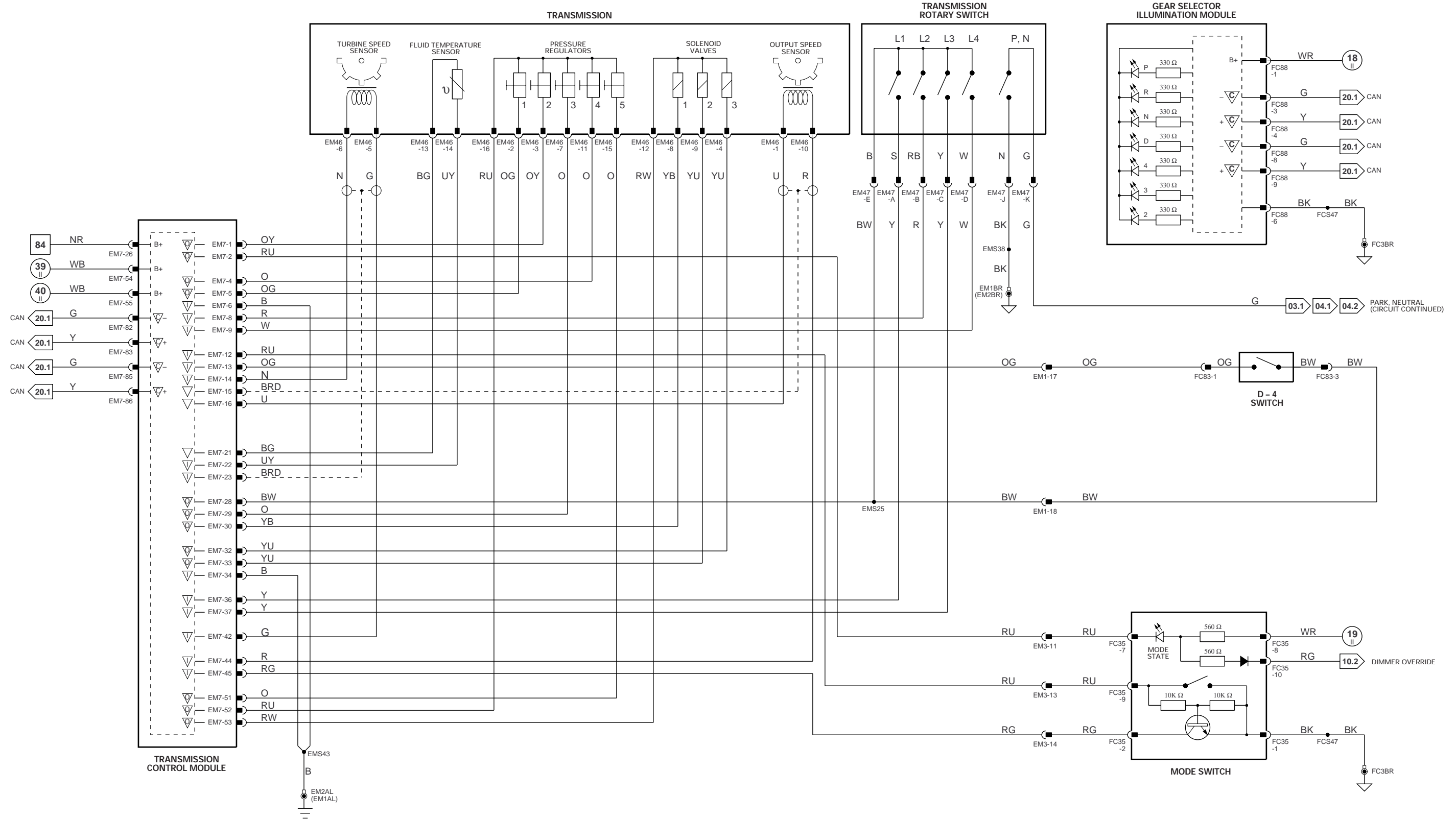

VARIANT: AJ27 N/A Vehicles  
 VIN RANGE: A00116 →  
 DATE OF ISSUE: September 1999



NOTE: n2 and n3 are internal gear ratio speed sensors.

NOTE: Pressure regulators: MD - modulation pressure SD - shift pressure

NOTE: Gear Selector Illumination Module - CAN "listen only" node for gear selector position indicators.

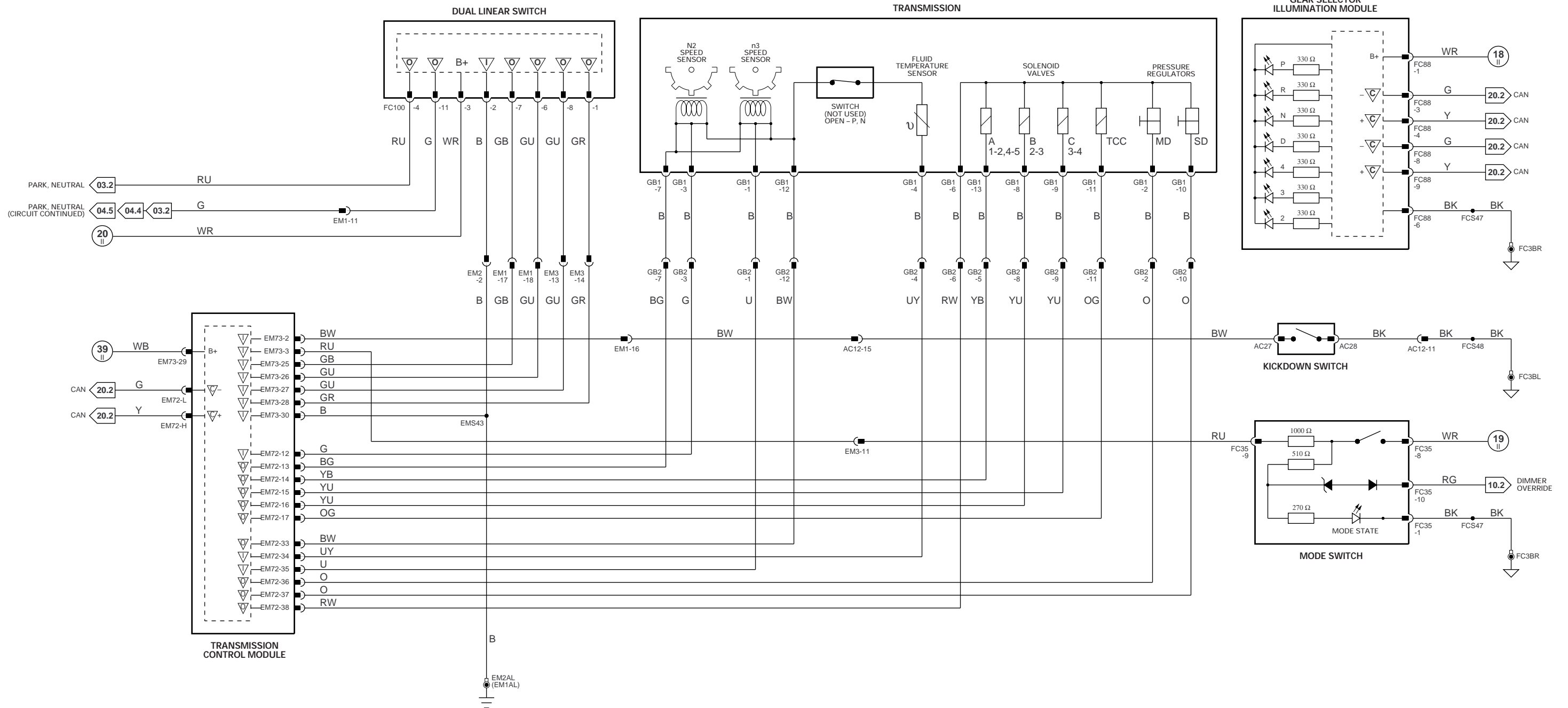

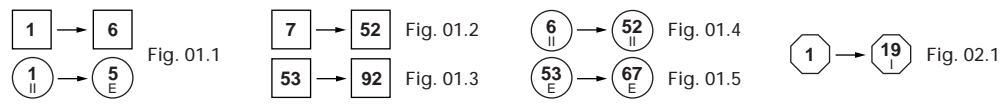
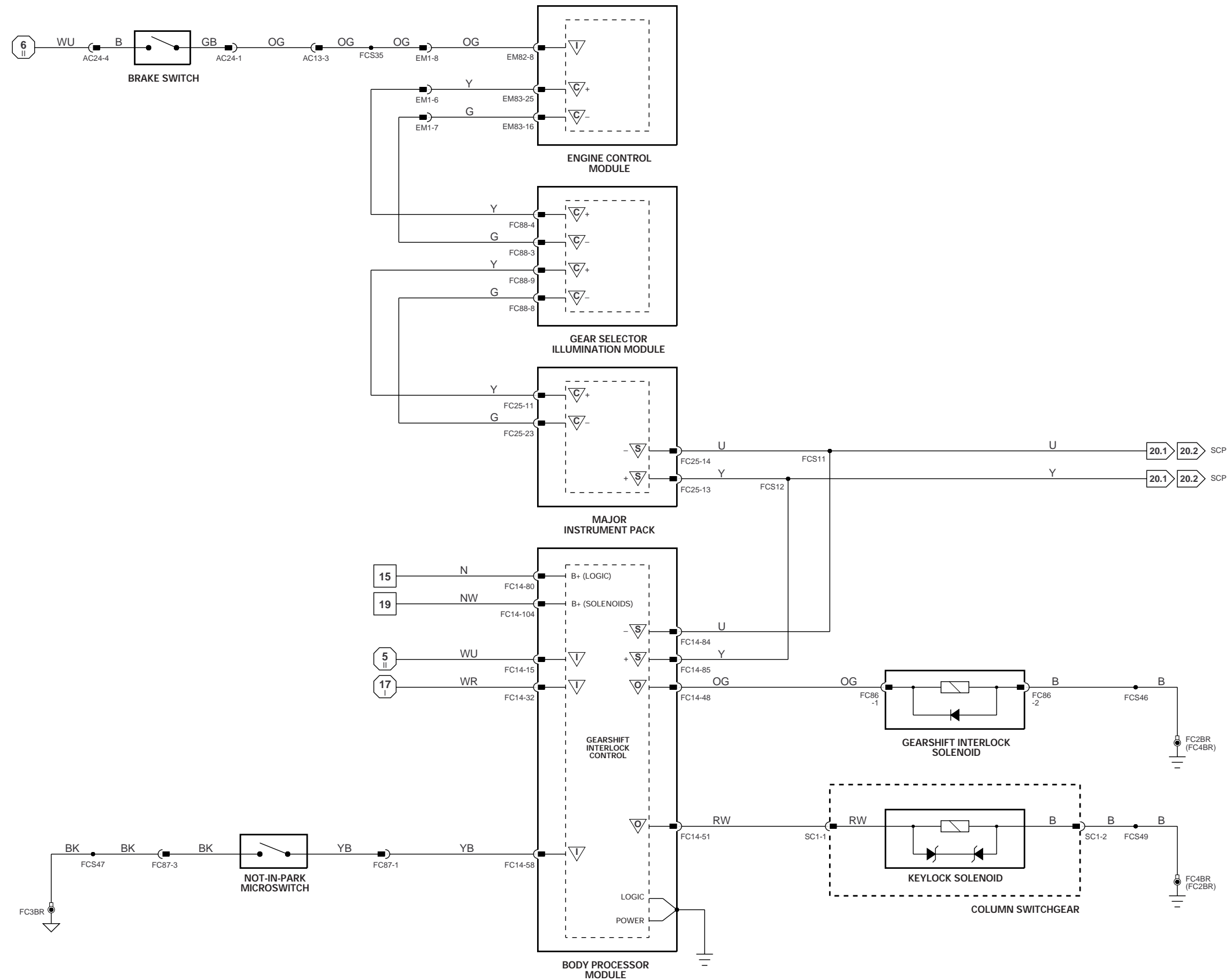

VARIANT: All Vehicles  
 VIN RANGE: A00116 →  
 DATE OF ISSUE: September 1999

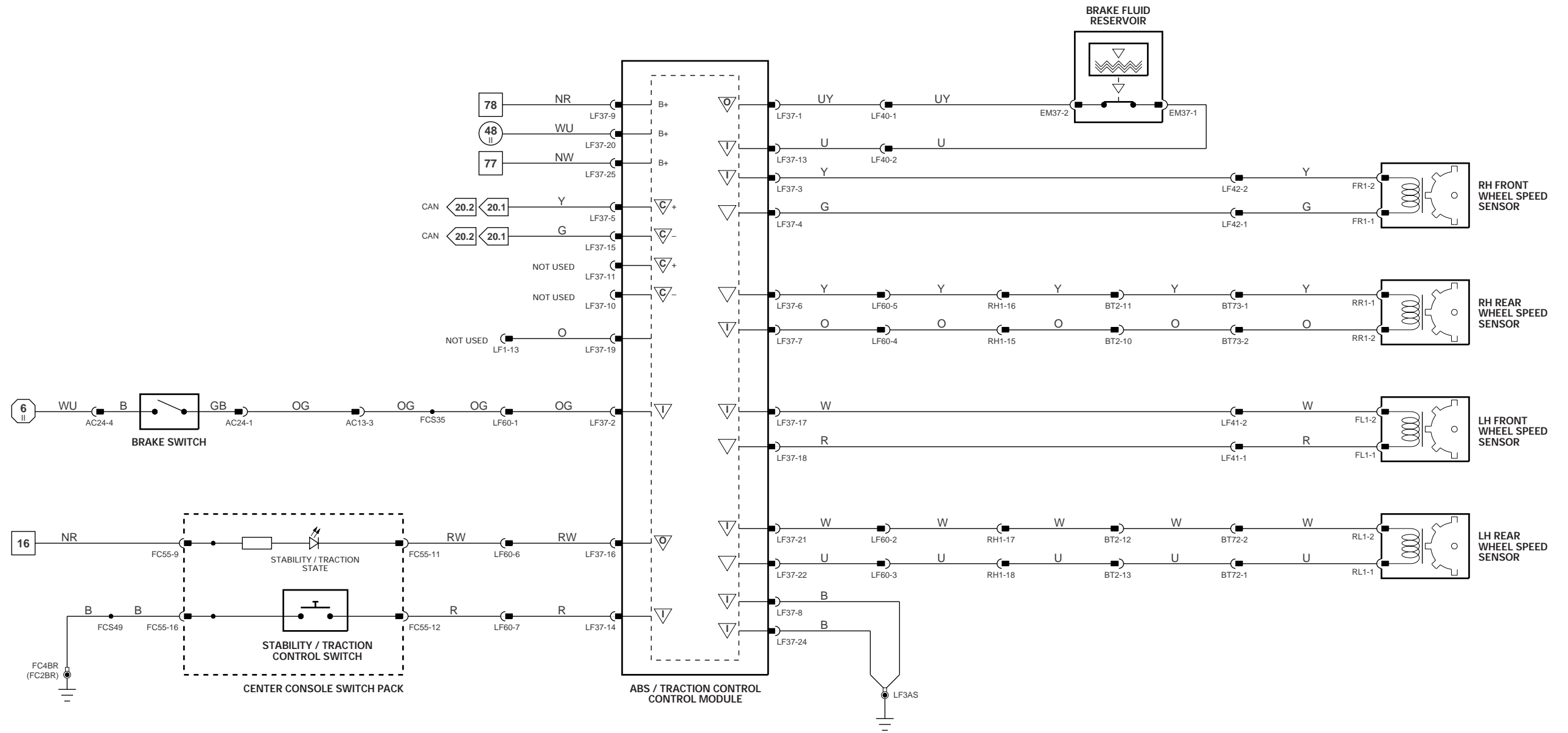

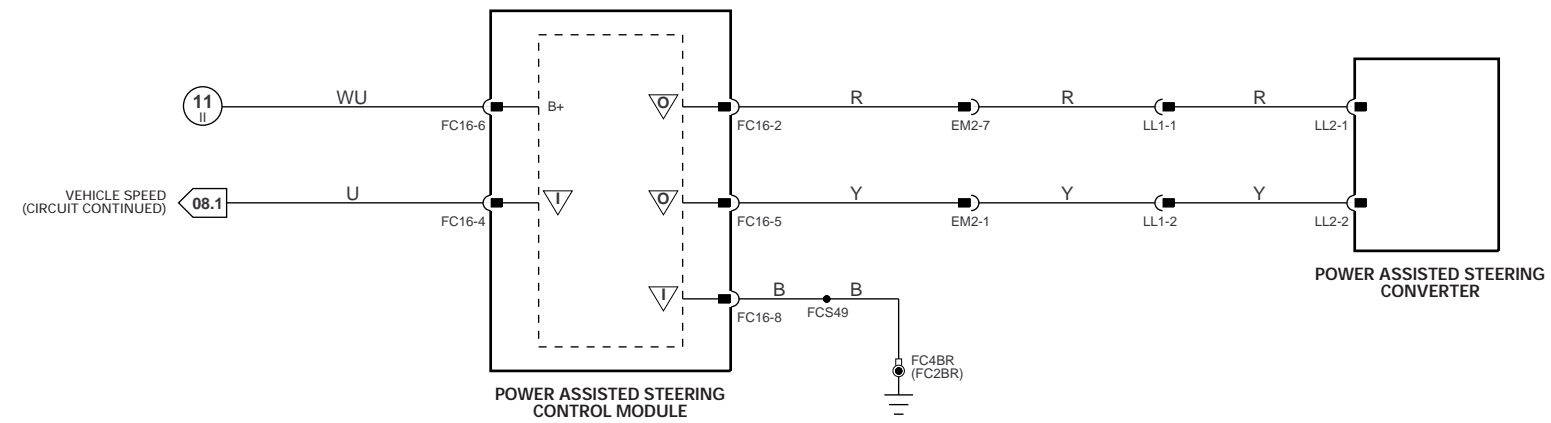

LHD

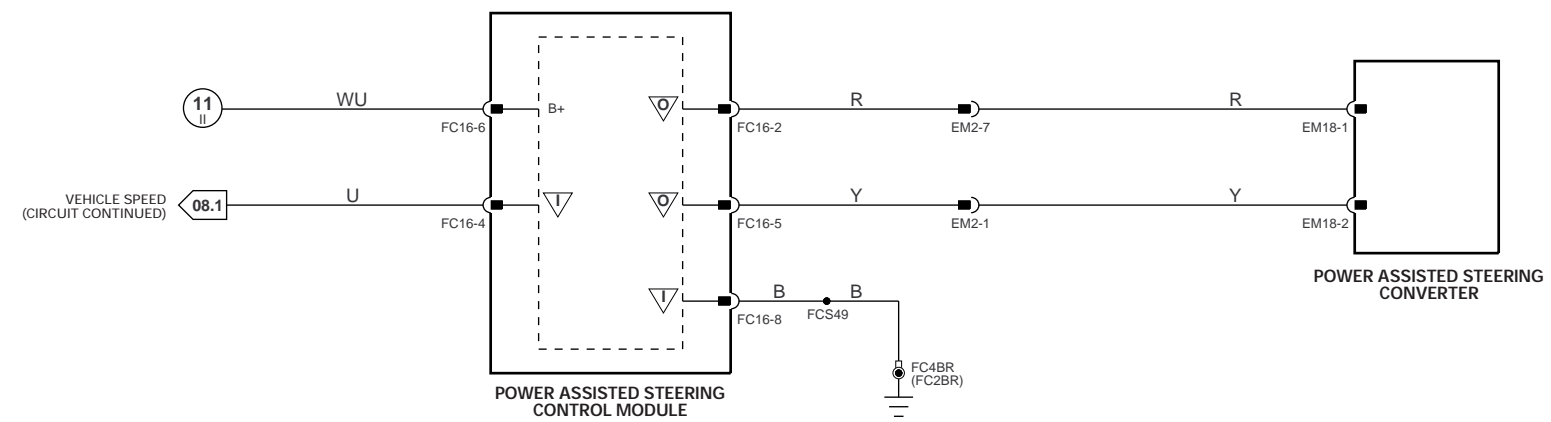

RHD

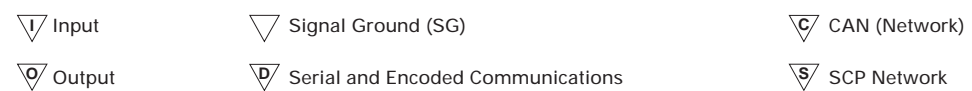

VARIANT: All Vehicles  
 VIN RANGE: A00116 →  
 DATE OF ISSUE: September 1999

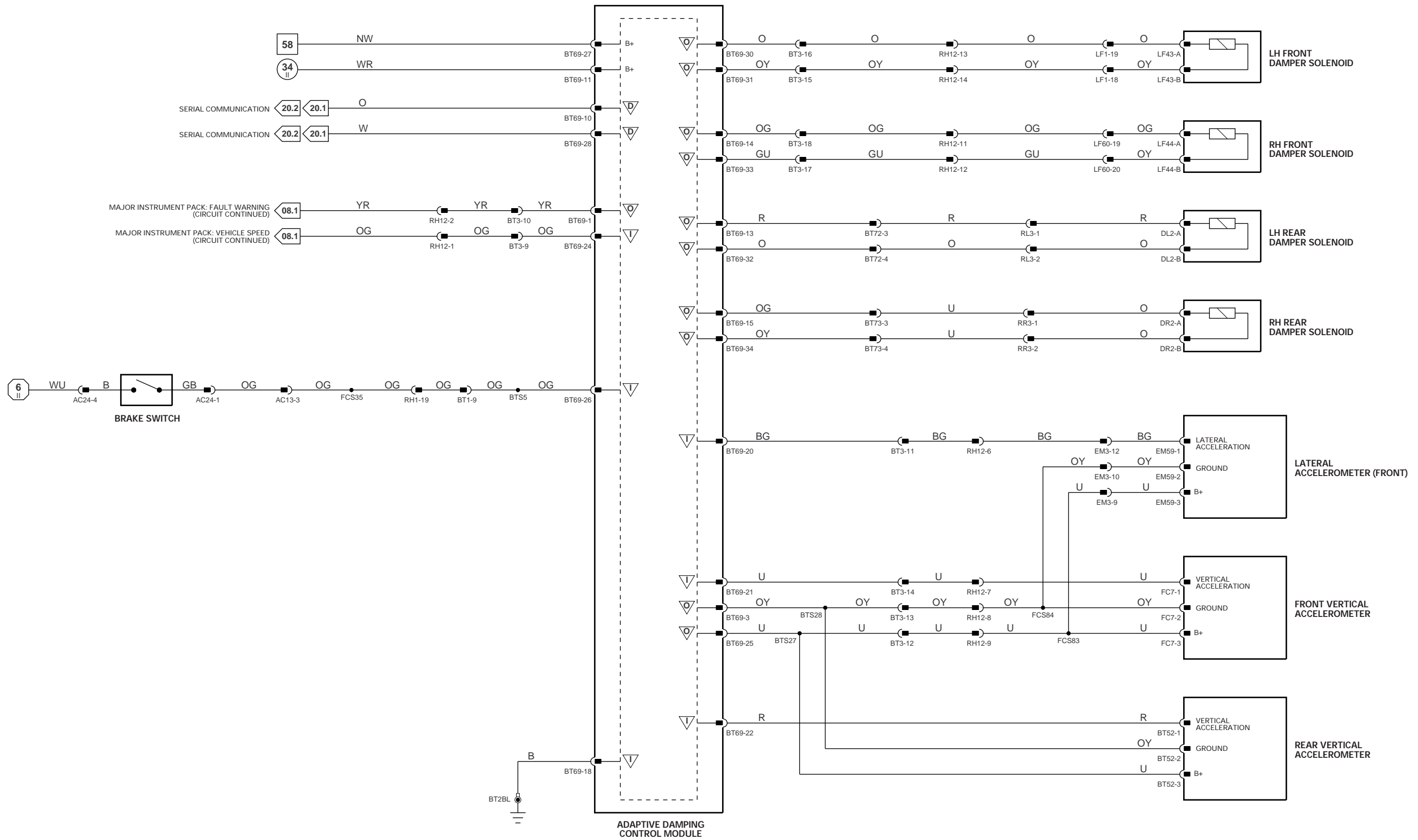

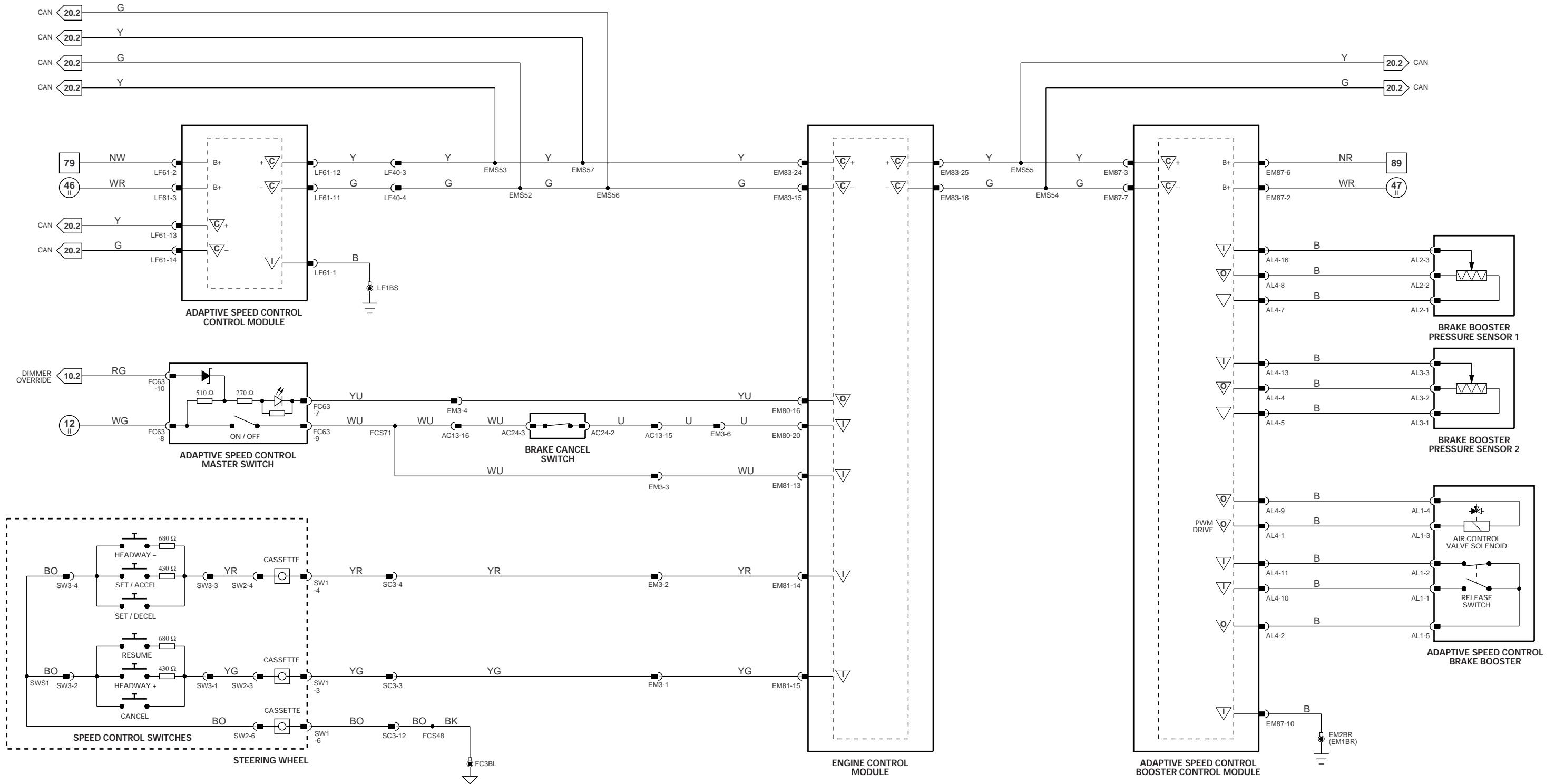

NOTE: ECM power supplies and grounds shown on Figs. 04.4, 04.5.

NOTE: Refer to Fig. 04.5 for the Throttle Control portion of Engine Management.

	<p>1 → 6 Fig. 01.1</p> <p>1 II → 5 E Fig. 01.5</p> <p>7 → 52 Fig. 01.2</p> <p>53 → 92 Fig. 01.3</p> <p>6 II → 52 II Fig. 01.4</p> <p>53 E → 67 E Fig. 01.5</p> <p>1 → 19 I Fig. 02.1</p>	<p>V Input</p> <p>V Output</p> <p>▽ Signal Ground (SG)</p> <p>▽ Serial and Encoded Communications</p> <p>▽ CAN (Network)</p> <p>▽ SCP Network</p>	<p>VARIANT: Adaptive Speed Control Vehicles</p> <p>VIN RANGE: A00116 →</p> <p>DATE OF ISSUE: September 1999</p>
--	--	---	---



**NOTES:** When the ignition switched ground input is interrupted during engine cranking, the A/CCM does not drive high power consuming components.

The A/C Isolate Relay remains energized by the A/CCM for 30 seconds after the ignition is switched OFF to provide power for the A/CCM to 'park' the servos.

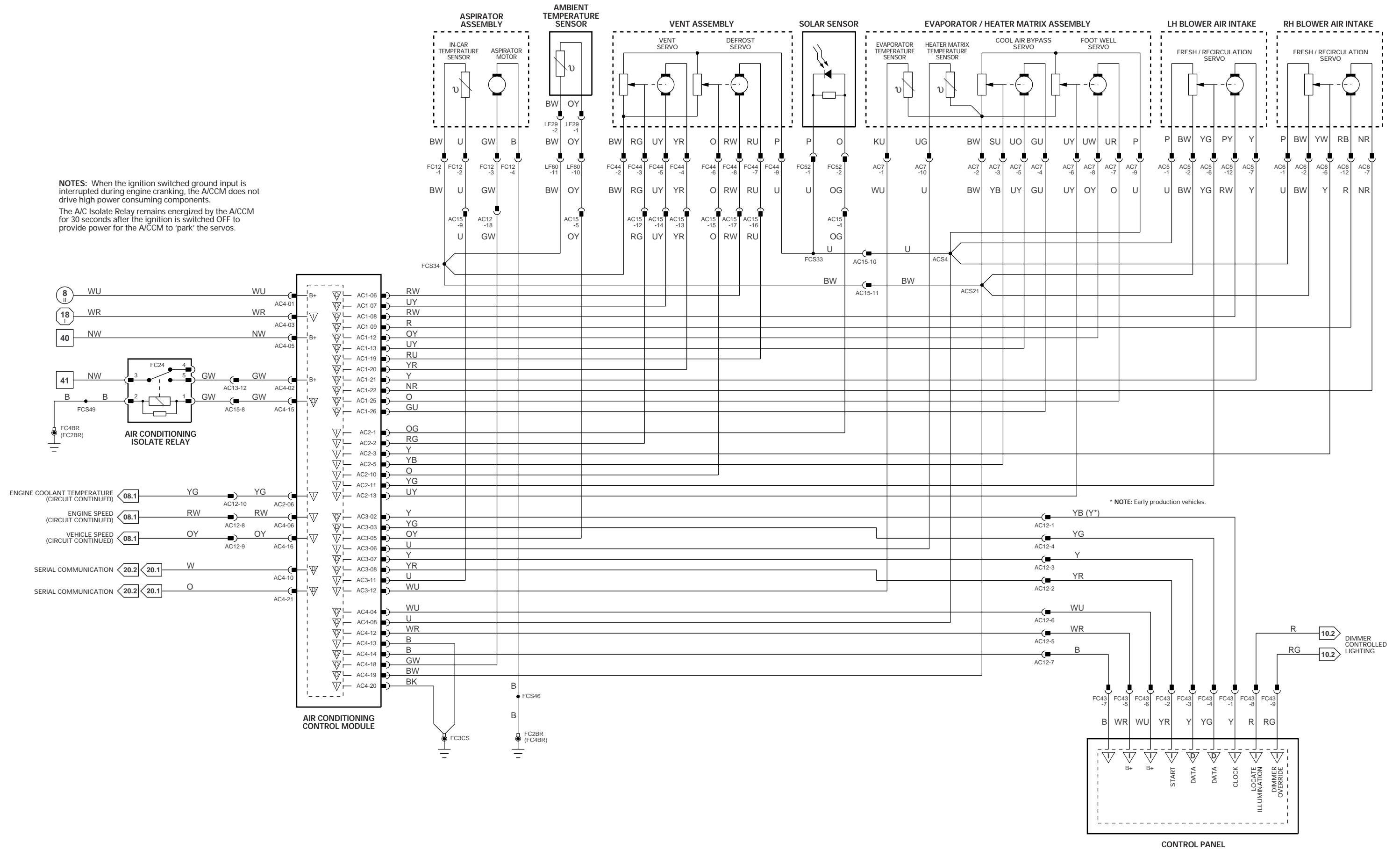



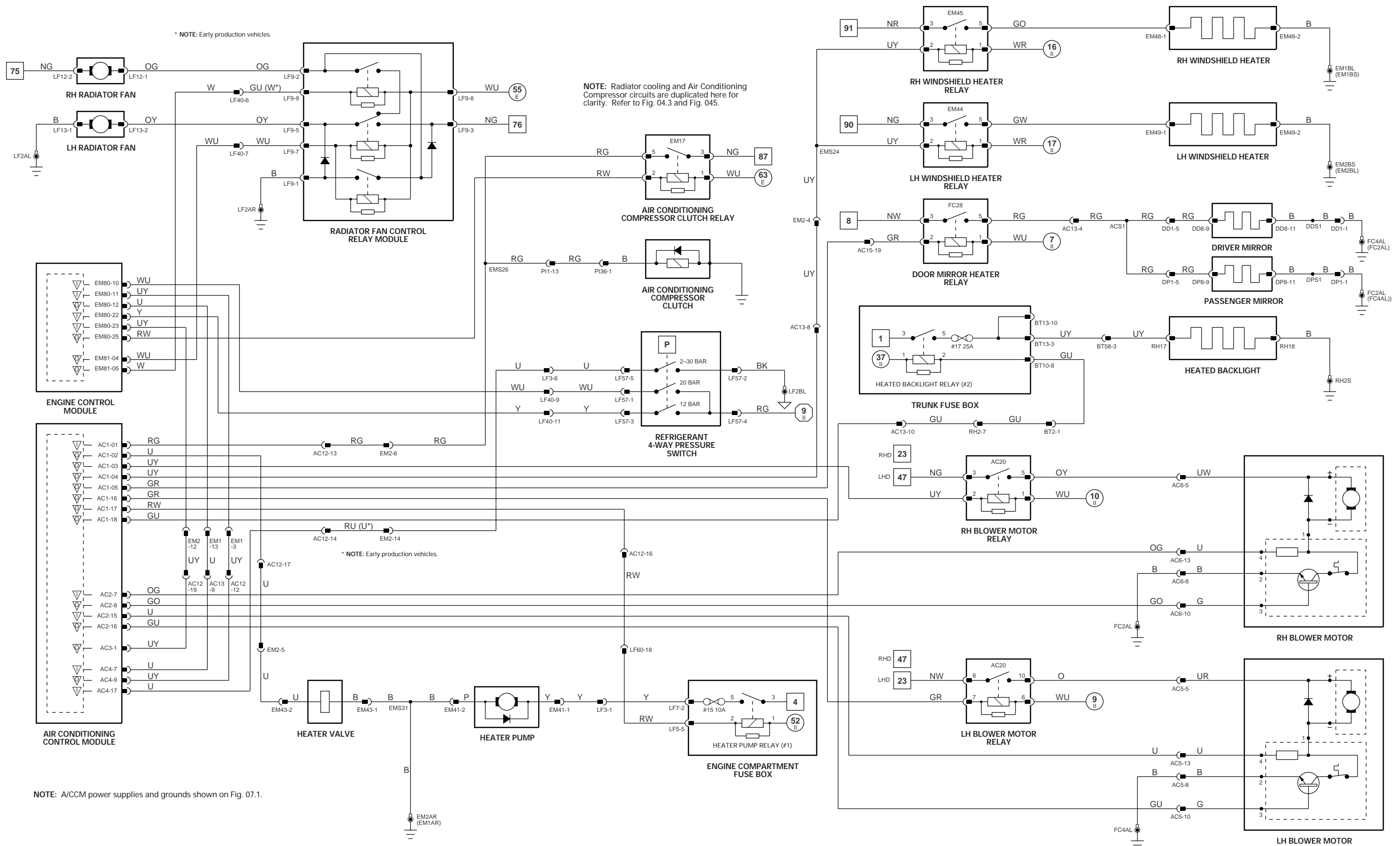

	<p>Fig. 01.1: 1 → 6, 1 → 5</p> <p>Fig. 01.2: 7 → 52, 53 → 92</p> <p>Fig. 01.4: 6 → 52, 53 → 67</p> <p>Fig. 02.1: 1 → 19</p>	<p>Input</p> <p>Output</p> <p>Signal Ground (SG)</p> <p>Serial and Encoded Communications</p> <p>CAN (Network)</p> <p>SCP Network</p>	<p><b>VARIANT:</b> All Vehicles</p> <p><b>VIN RANGE:</b> A00116 →</p> <p><b>DATE OF ISSUE:</b> September 1999</p>
--	---	---	---

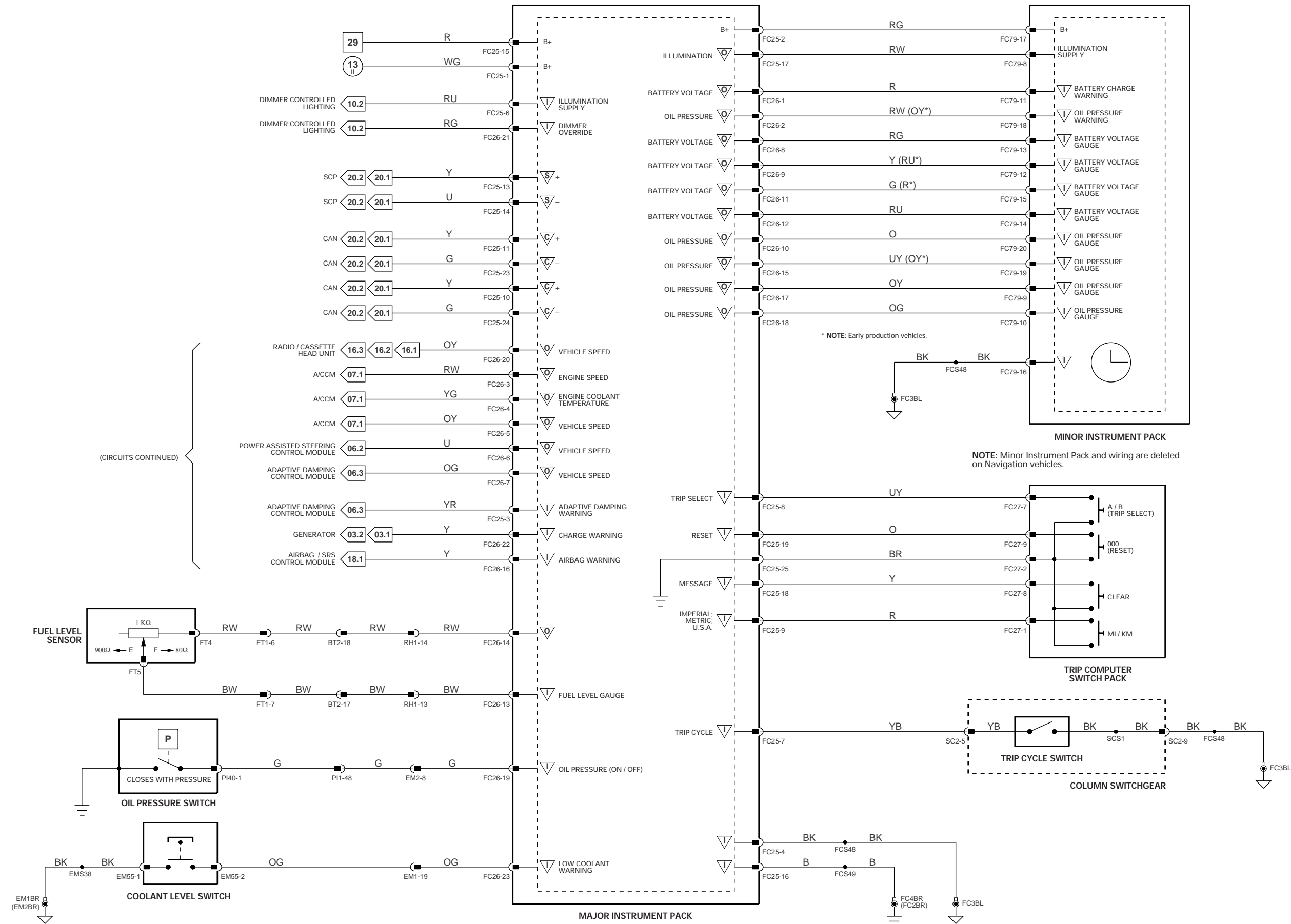



SCP SOURCES:

- DIRECTION INDICATORS; HAZARD WARNING; SIDE LAMPS - Fig. 09.1, Fig. 09.2
- VALET SWITCH; TRUNK RELEASE - Fig. 13.1
- MEMORY - Fig. 12.1
- CONVERTIBLE TOP MOVEMENT - Fig. 15.2
- KEY-IN-IGNITION SWITCH / DRIVER DOOR SWITCH - Fig. 13.1
- NOT-IN-PARK MICROSWITCH - Fig. 05.3
- SEAT BELT SWITCH - Fig. 12.1

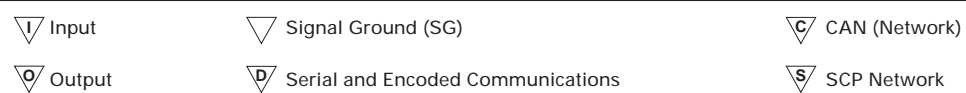
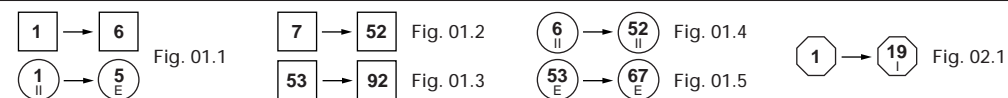
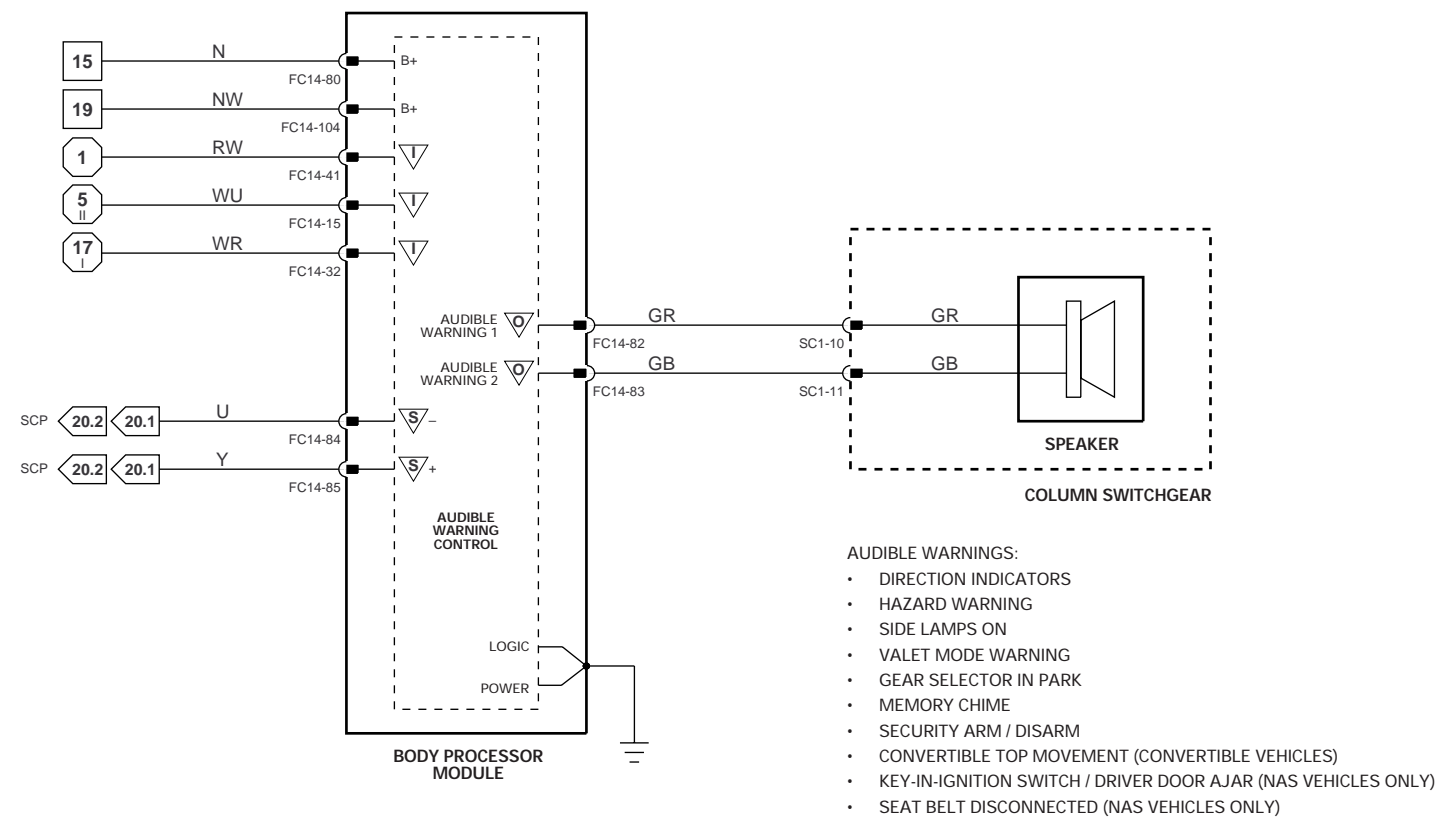

VARIANT: All Vehicles  
 VIN RANGE: A00116 →  
 DATE OF ISSUE: September 1999



NOTE: 'Crank' input used with Daytime Running Lamps.

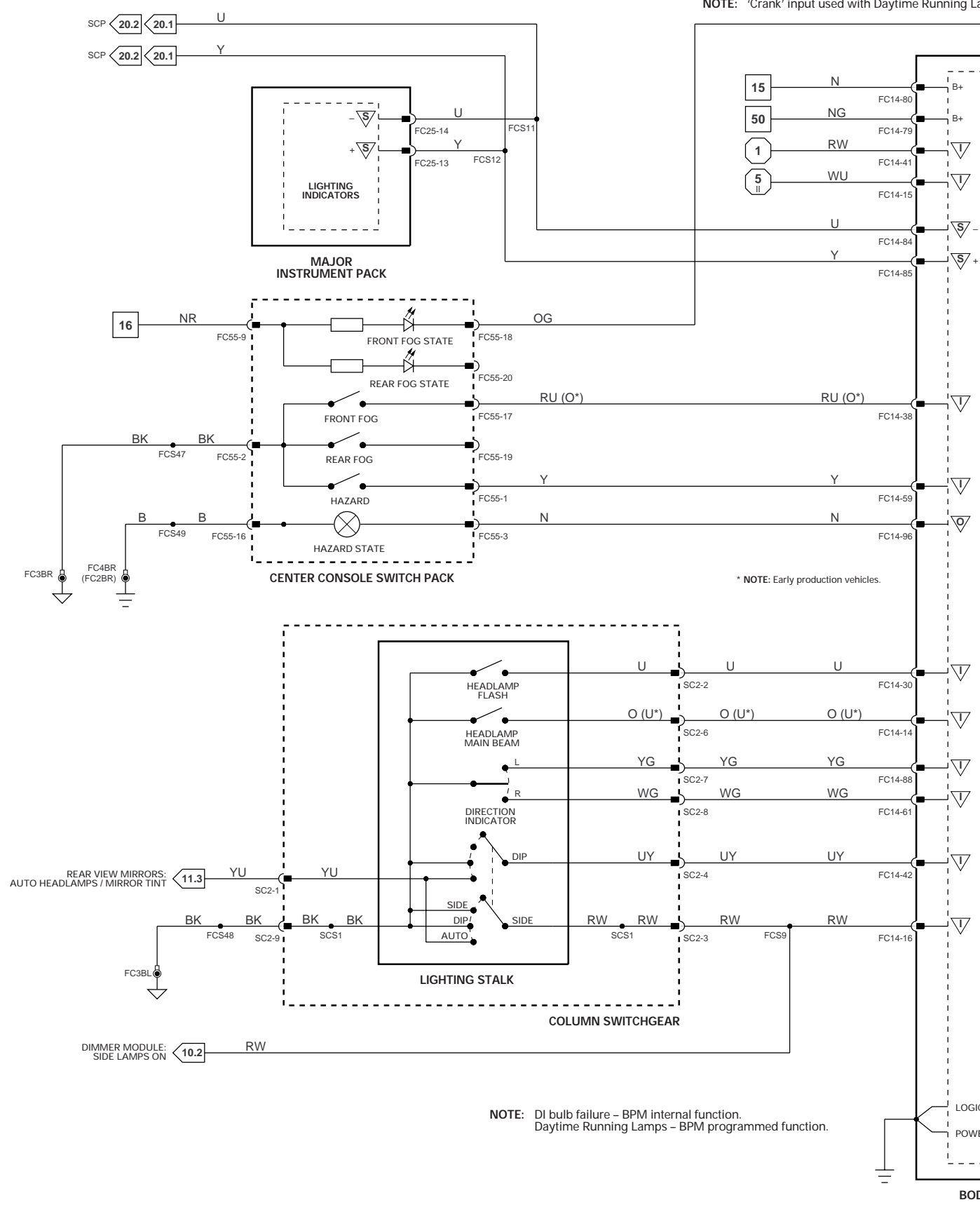

NOTE: DI bulb failure - BPM internal function. Daytime Running Lamps - BPM programmed function.

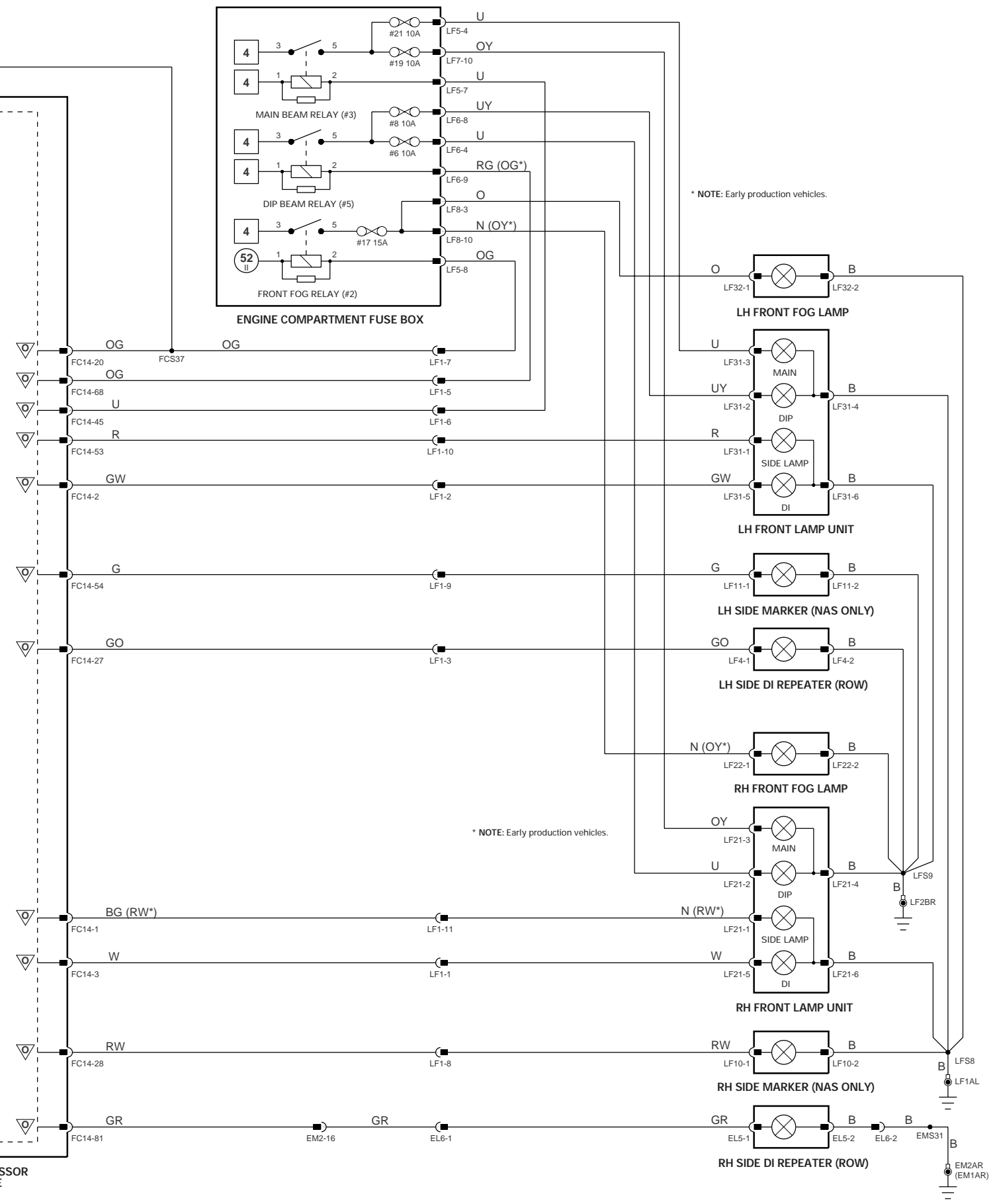

\* NOTE: Early production vehicles.

\* NOTE: Early production vehicles.

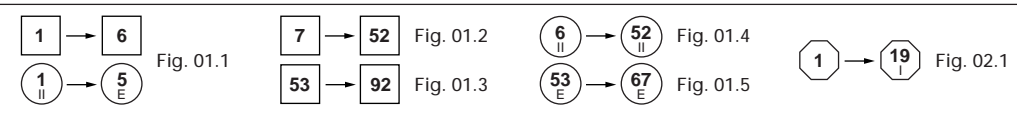

VARIANT: All Vehicles  
 VIN RANGE: A00116 →  
 DATE OF ISSUE: September 1999

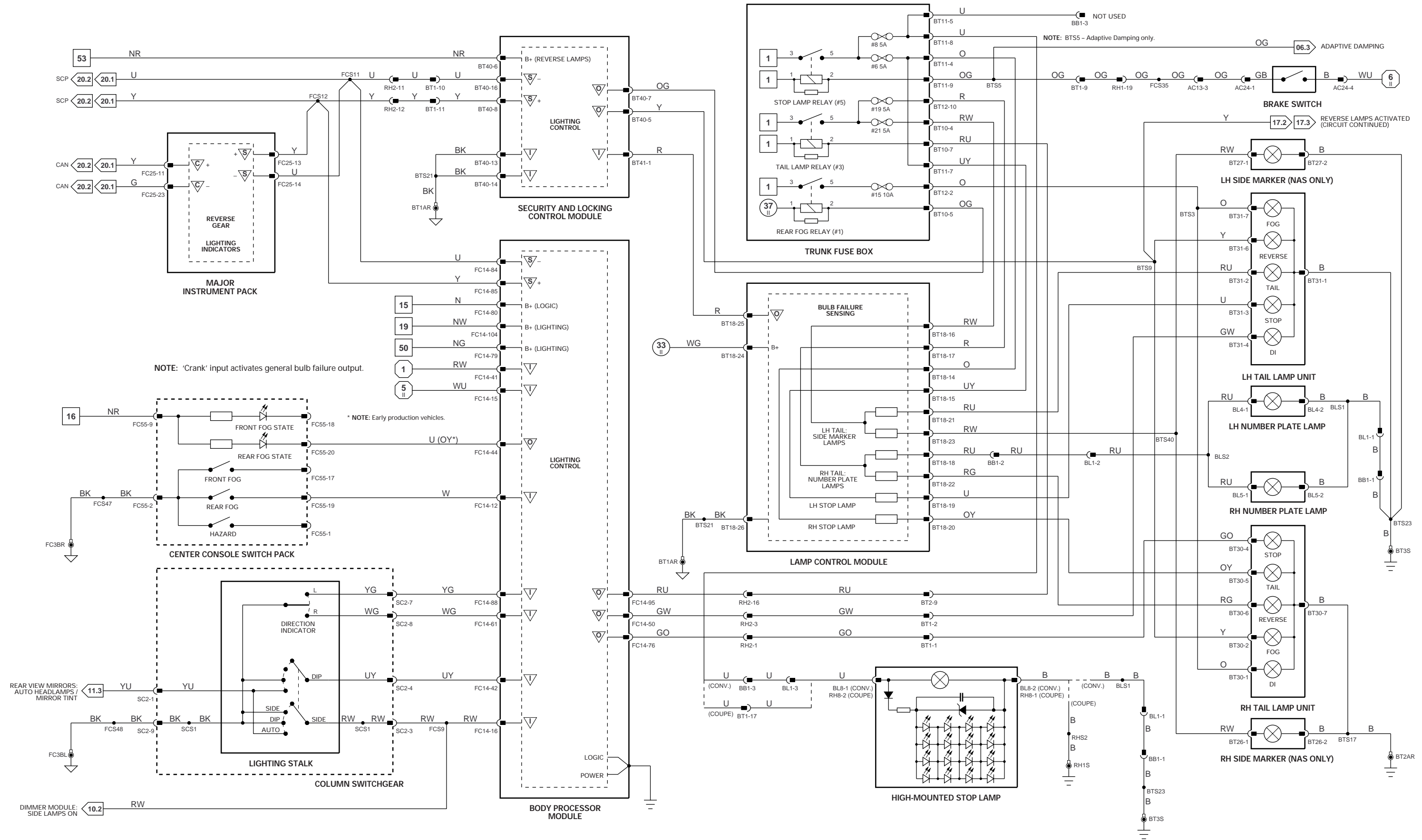

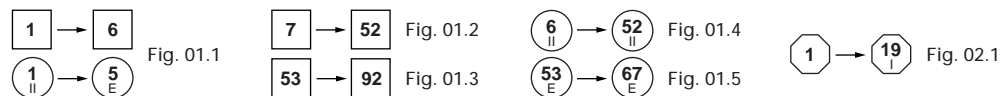
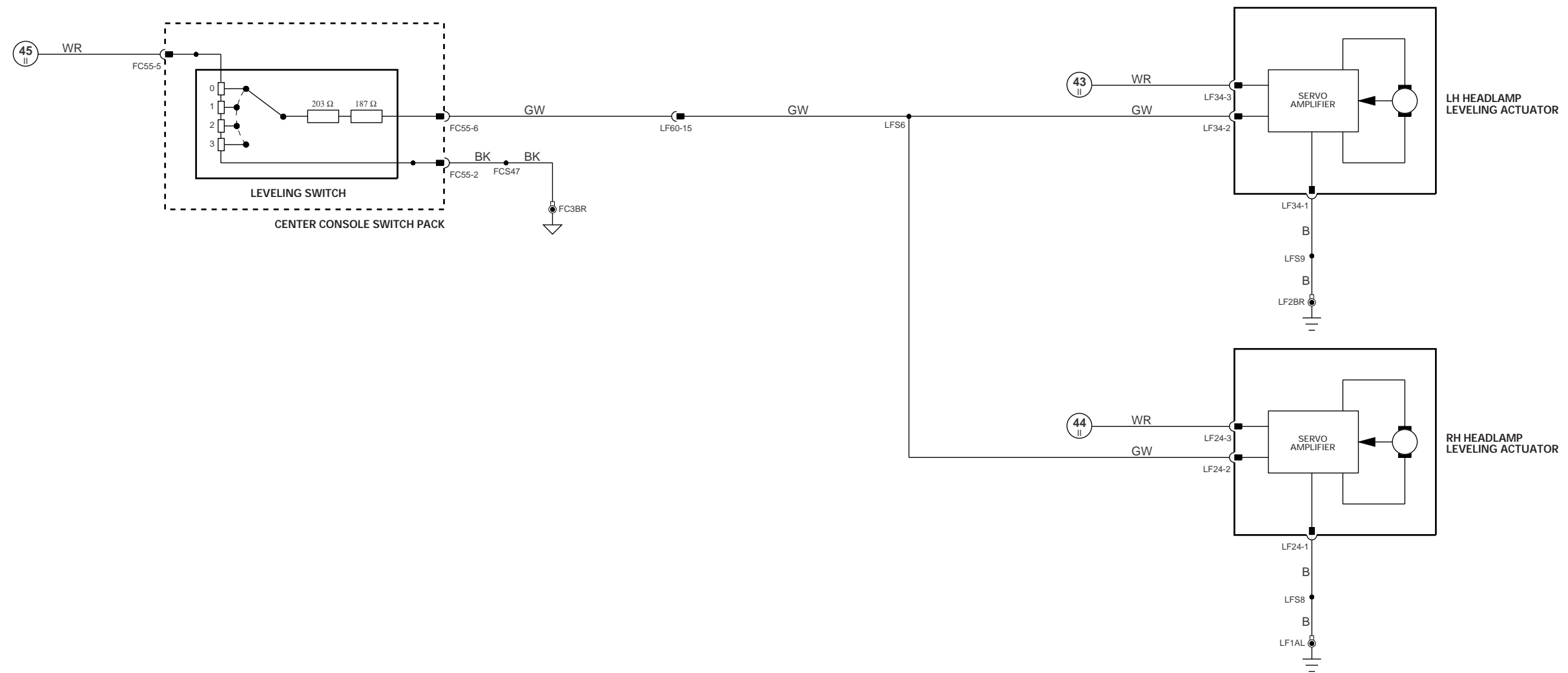

▽ Input  
 ▽ Output  
 ▽ Signal Ground (SG)  
 ▽ Serial and Encoded Communications  
 ▽ CAN (Network)  
 ▽ SCP Network

**VARIANT:** Headlamp Leveling Vehicles  
**VIN RANGE:** A00116 →  
**DATE OF ISSUE:** September 1999



NOTE: 'Crank' input is used to switch off interior lamps during engine cranking.

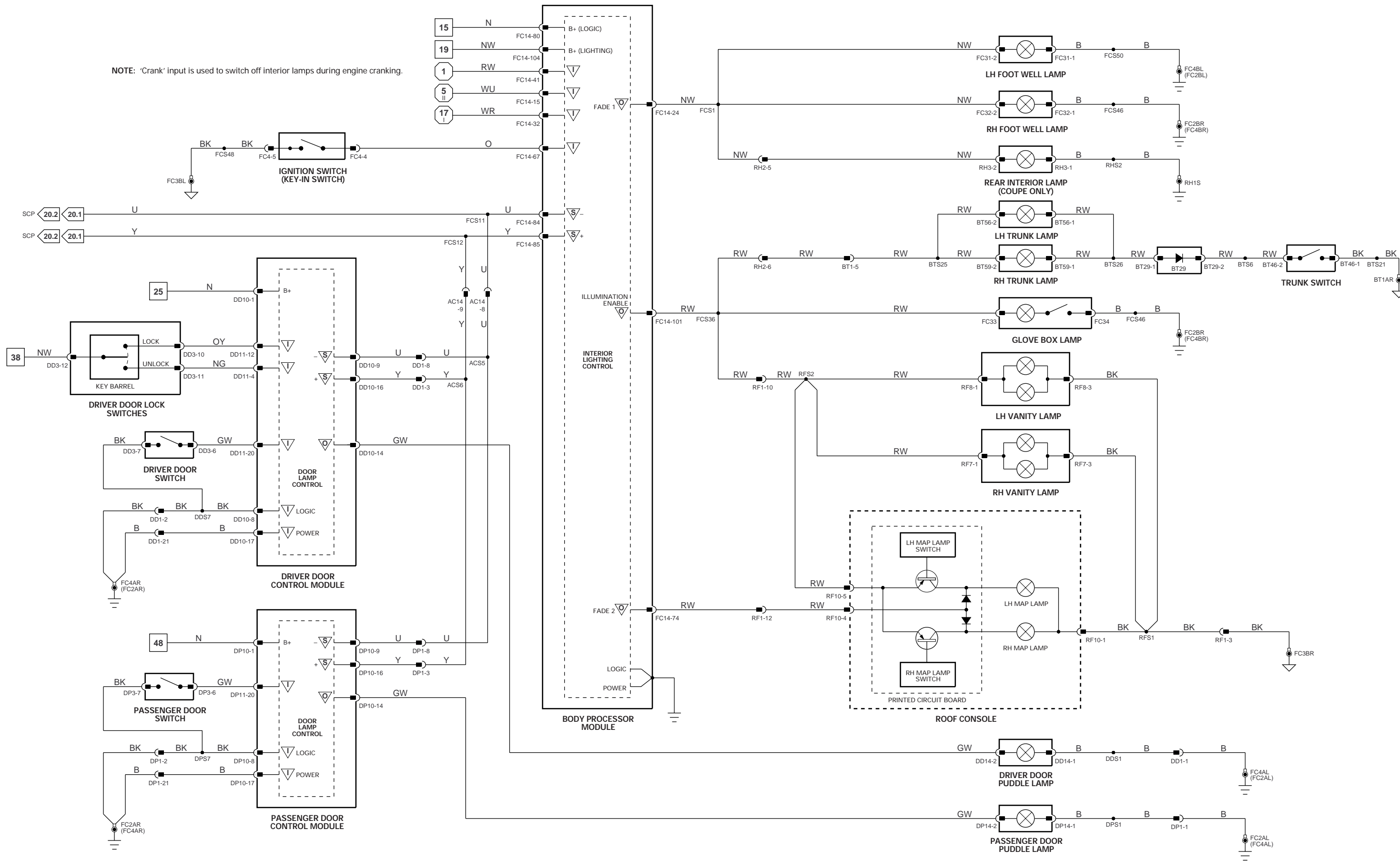

<p>1 → 6 Fig. 01.1    7 → 52 Fig. 01.2    6 → 52 Fig. 01.4    1 → 19 Fig. 02.1</p> <p>1 → 5 Fig. 01.3    53 → 92 Fig. 01.5    53 → 67 Fig. 01.5</p>	<p>▽ Input</p> <p>▽ Output</p>	<p>▽ Signal Ground (SG)</p> <p>▽ Serial and Encoded Communications</p>	<p>▽ CAN (Network)</p> <p>▽ SCP Network</p>

VARIANT: All Vehicles  
 VIN RANGE: A00116 →  
 DATE OF ISSUE: September 1999

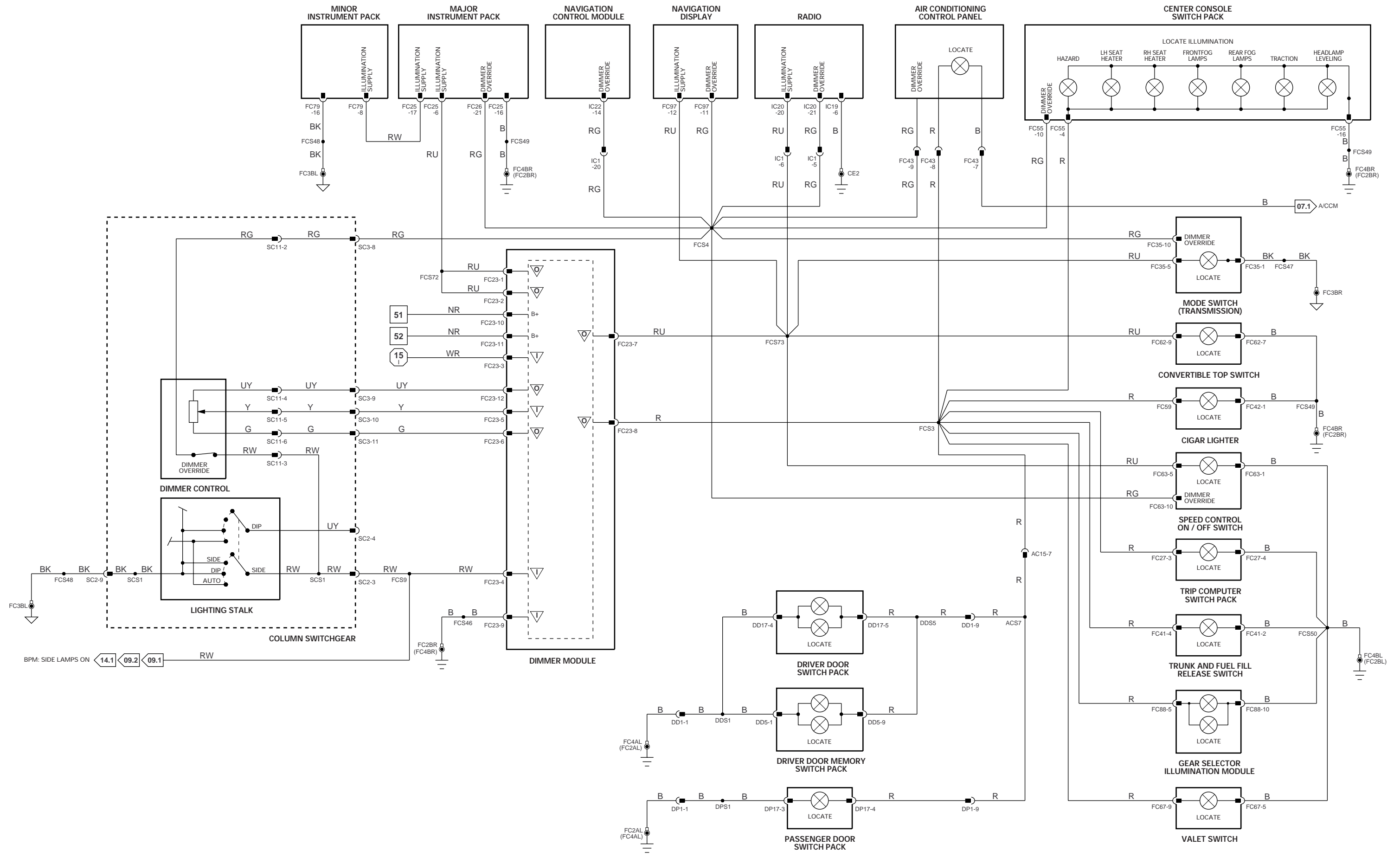



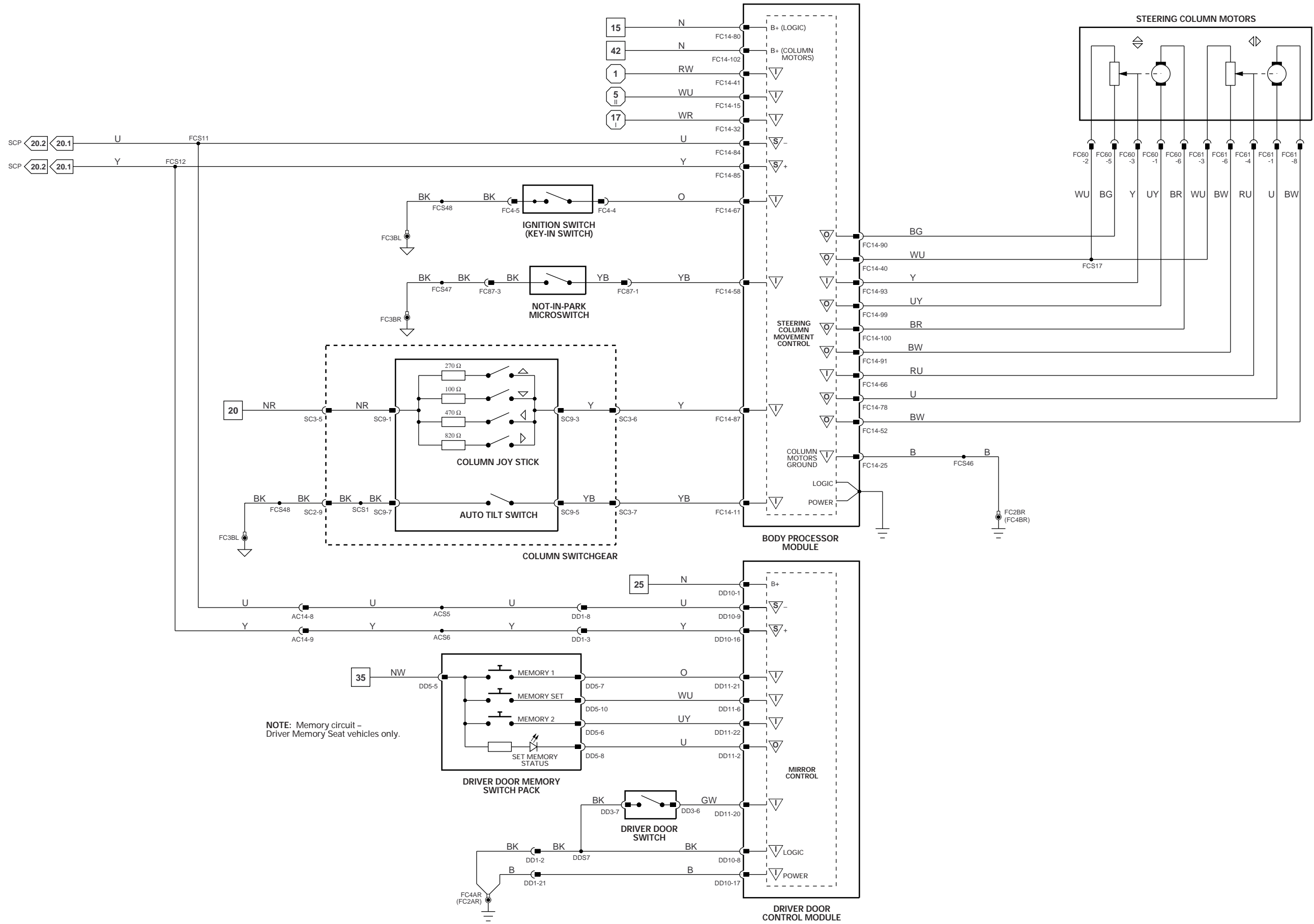

NOTE: Memory circuit - Driver Memory Seat vehicles only.

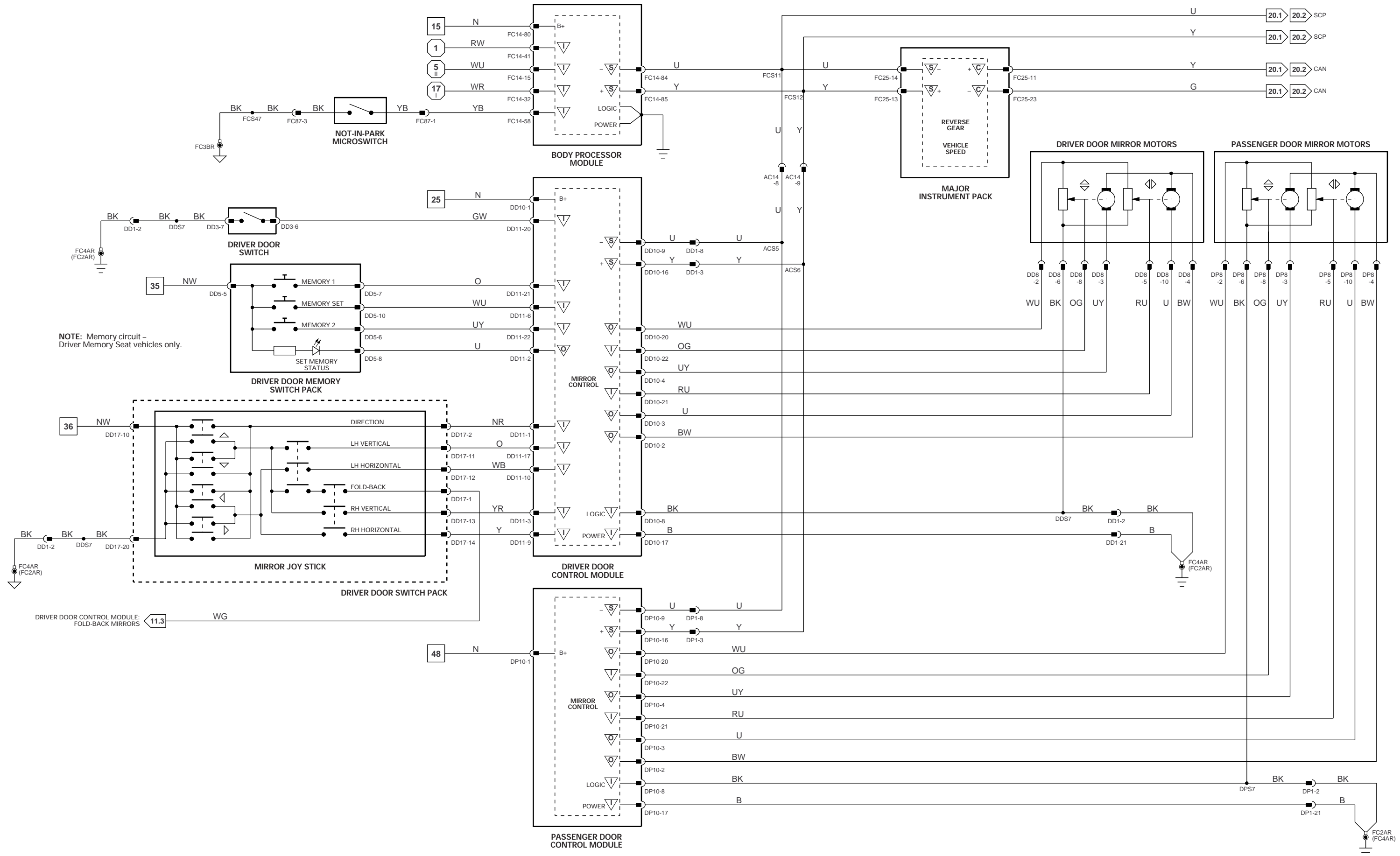

NOTE: Memory circuit - Driver Memory Seat vehicles only.

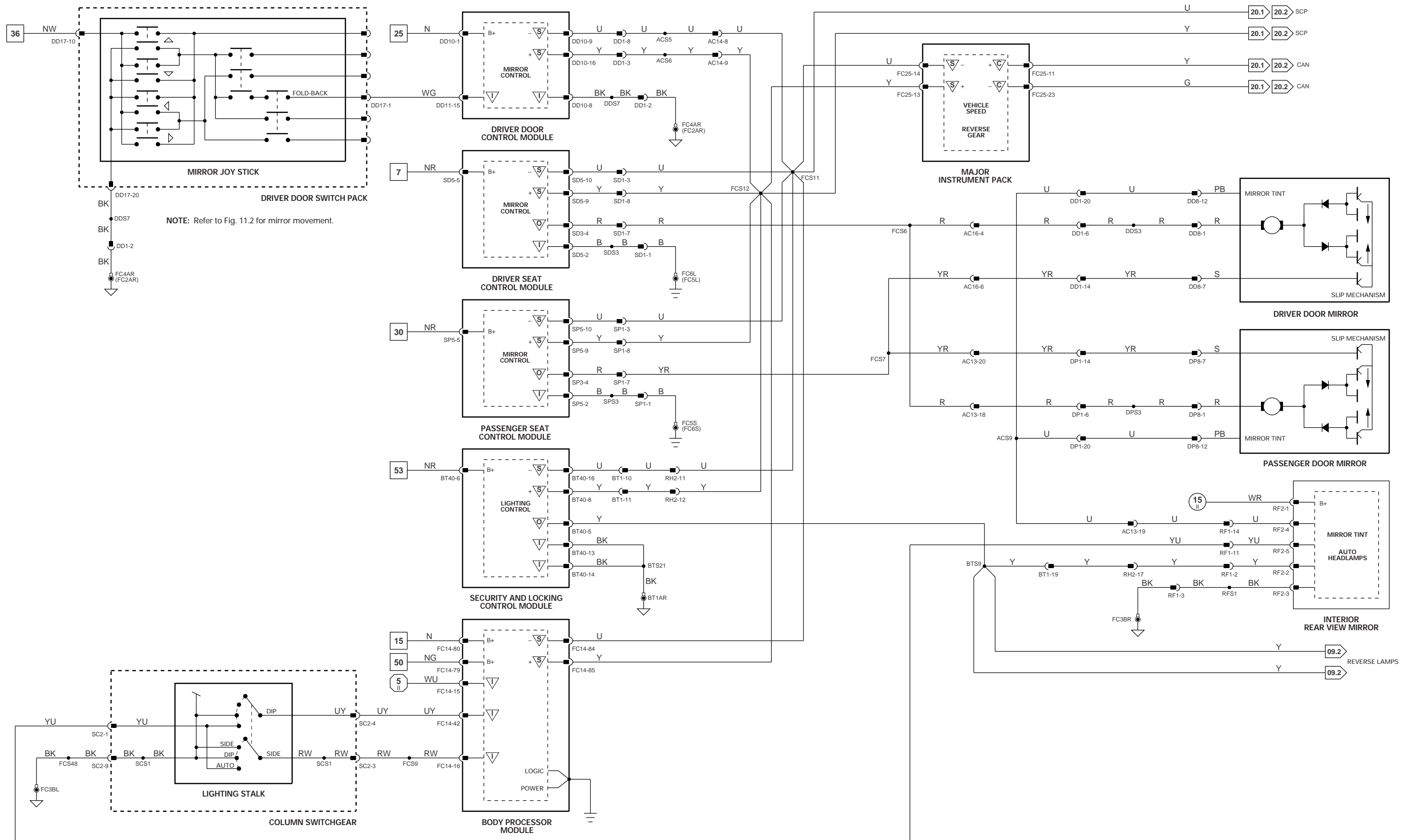

NOTE: Refer to Fig. 11.2 for mirror movement.

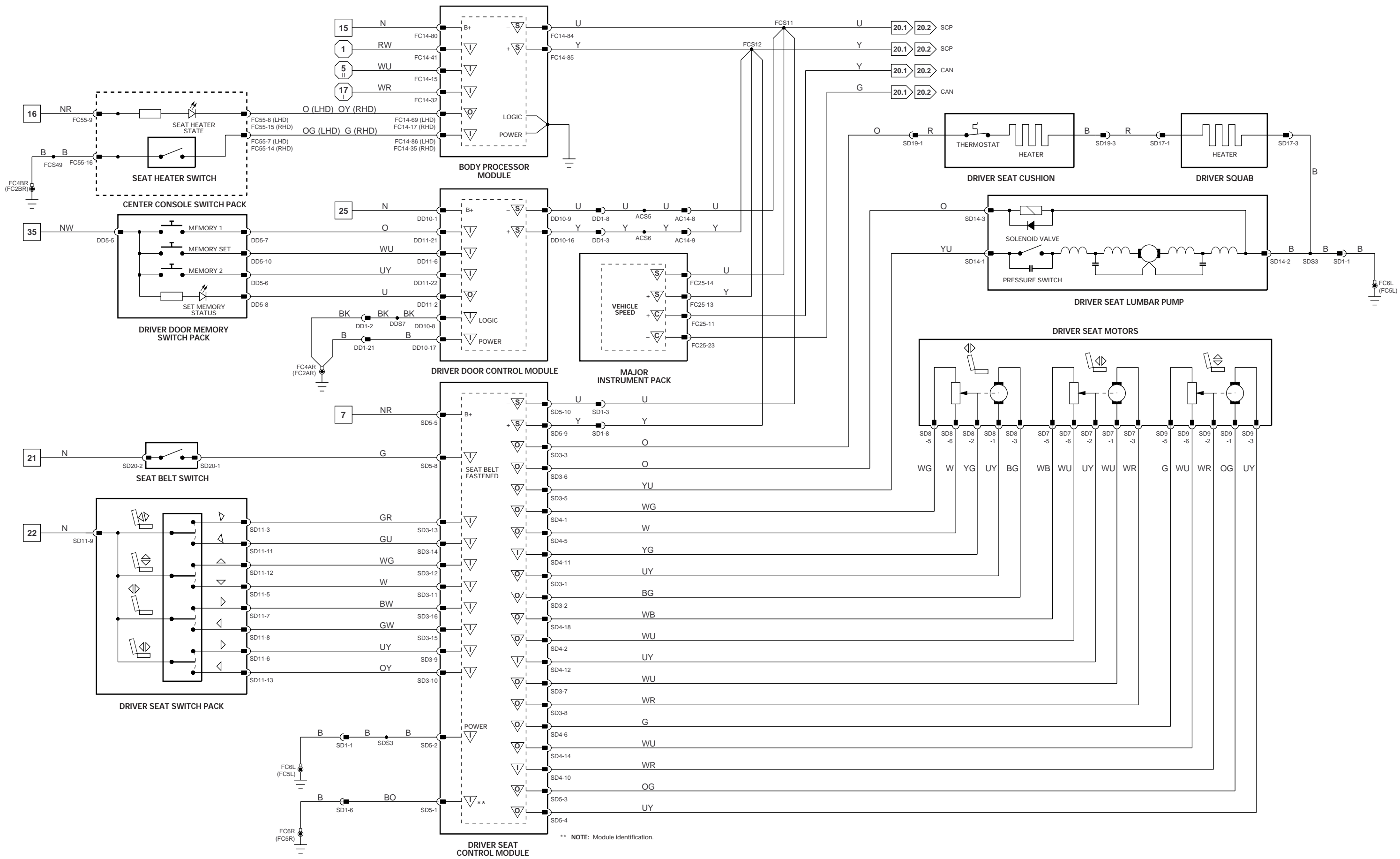

\*\* NOTE: Module identification.

	<p>Fig. 01.1: 1 → 6, 1 → 5</p> <p>Fig. 01.2: 7 → 52, 53 → 92</p> <p>Fig. 01.4: 6 → 52, 53 → 67</p> <p>Fig. 02.1: 1 → 19</p>	<p>V Input</p> <p>▽ Signal Ground (SG)</p> <p>▽ CAN (Network)</p> <p>▽ Serial and Encoded Communications</p> <p>▽ SCP Network</p>	<p>VARIANT: Memory Seat Vehicles</p> <p>VIN RANGE: A00116 →</p> <p>DATE OF ISSUE: September 1999</p>
--	---	---	--

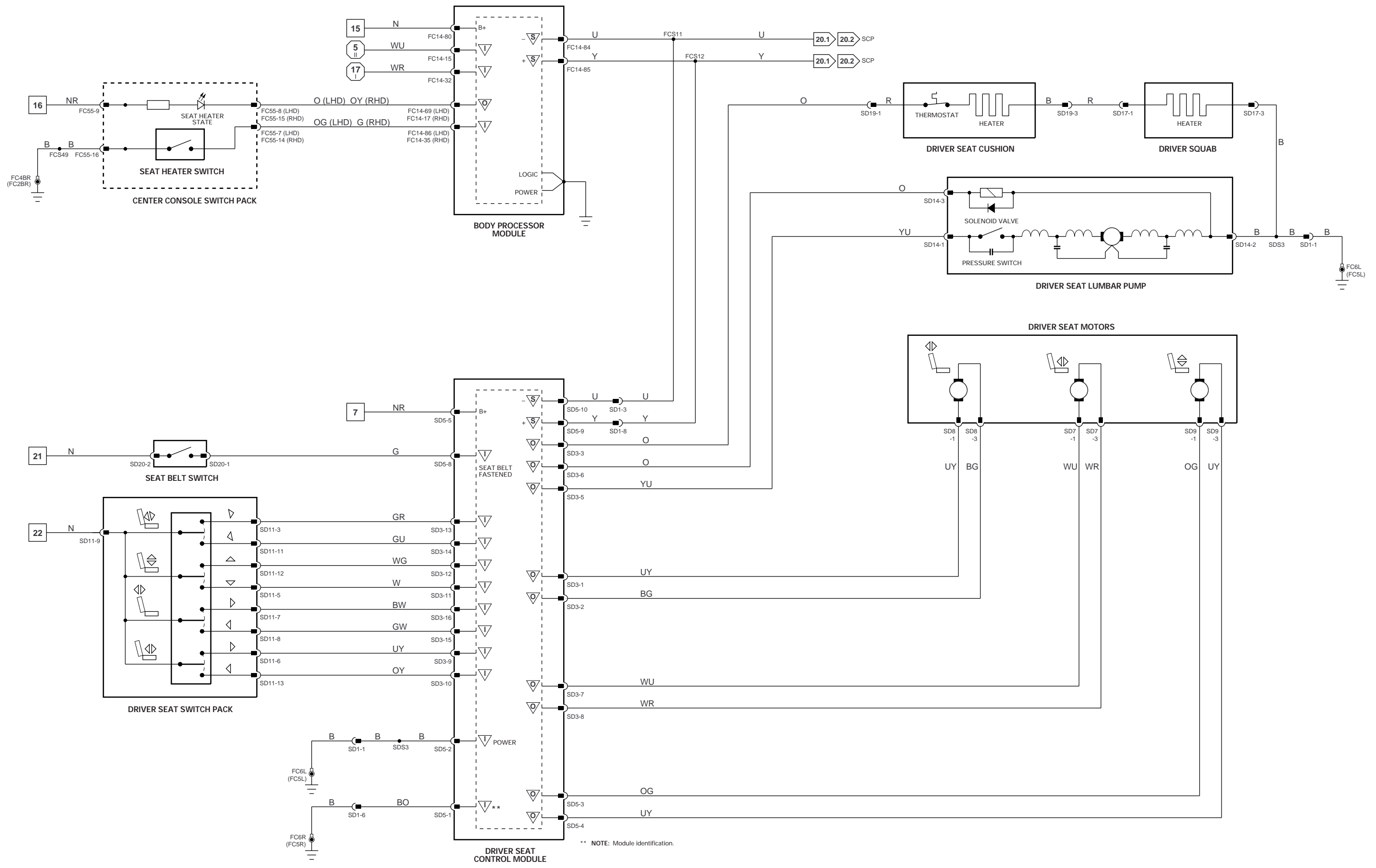

\*\* NOTE: Module identification.

Fig. 01.1 Fig. 01.1	Fig. 01.2 Fig. 01.3	Fig. 01.4 Fig. 01.5	Fig. 02.1	Input Output	Signal Ground (SG) Serial and Encoded Communications	CAN (Network) SCP Network	<b>VARIANT:</b> Non Memory Seat Vehicles <b>VIN RANGE:</b> A00116 → <b>DATE OF ISSUE:</b> September 1999
------------------------	------------------------	------------------------	-----------	-----------------	---	------------------------------	--

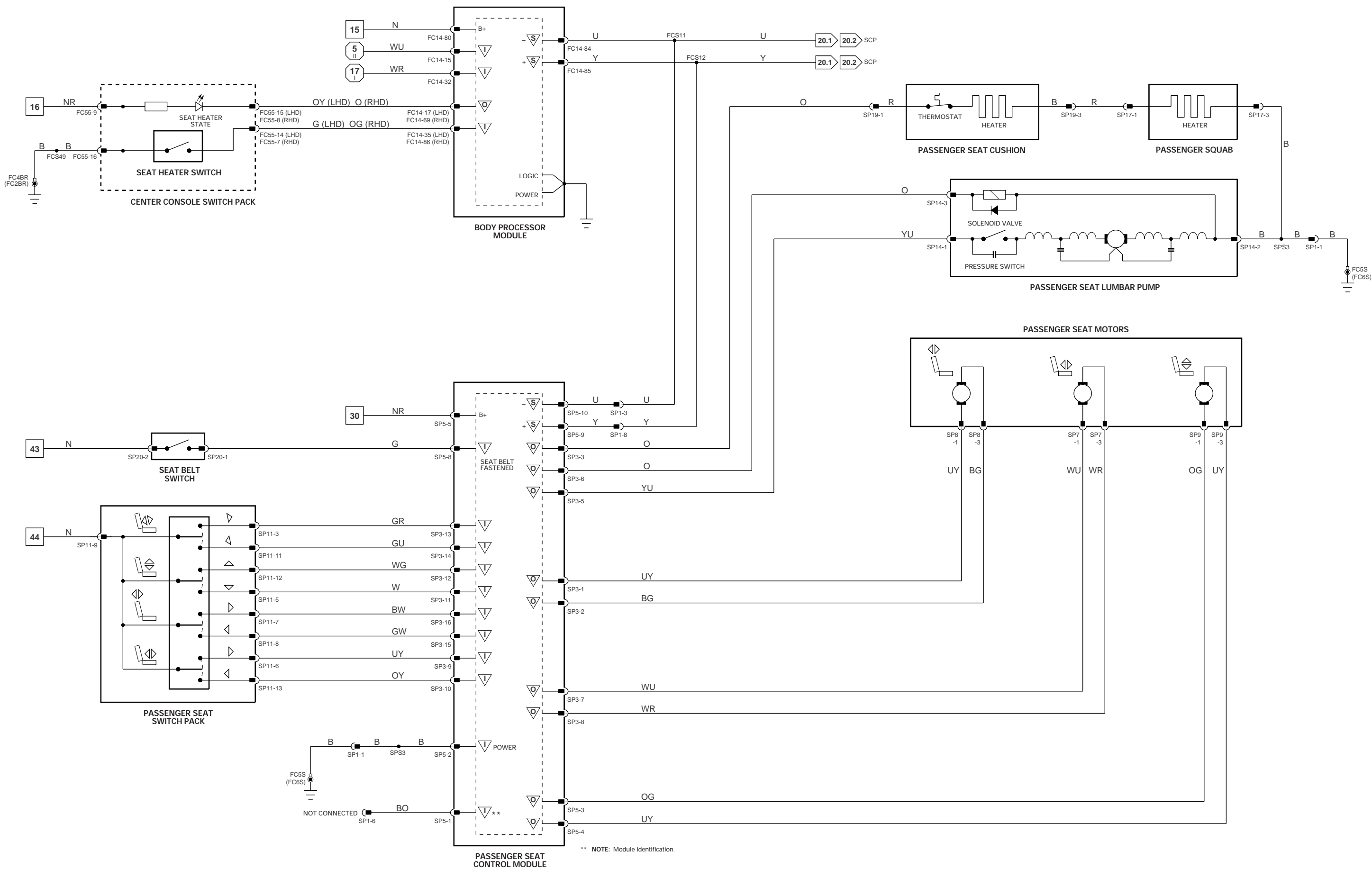

\*\* NOTE: Module identification.

		<p><b>VARIANT:</b> 3-Way Movement Vehicles  <b>VIN RANGE:</b> A00116 →  <b>DATE OF ISSUE:</b> September 1999</p>
--	--	--

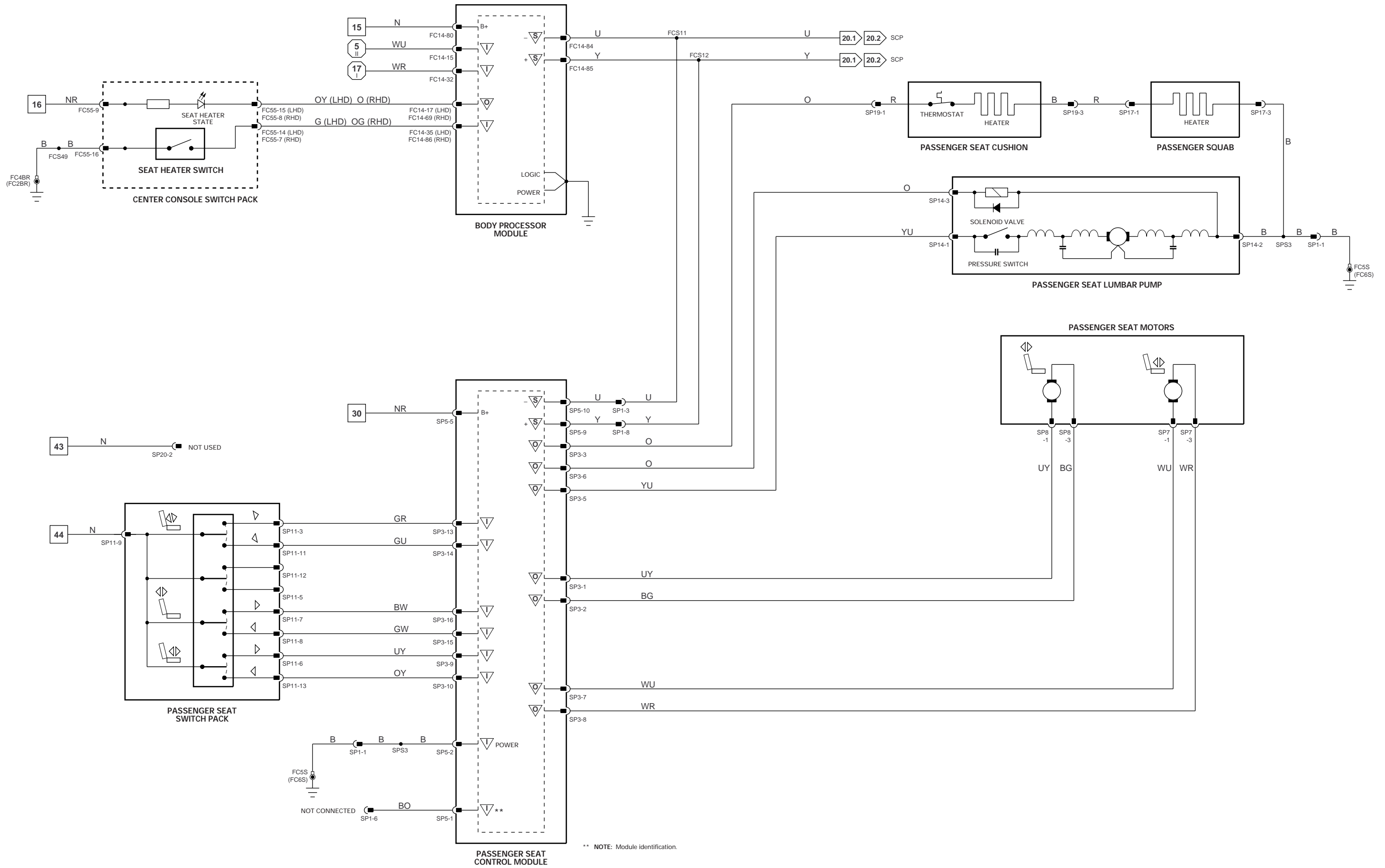



NOTE: Ignition switched ground via Inertia Switch activates emergency unlock.

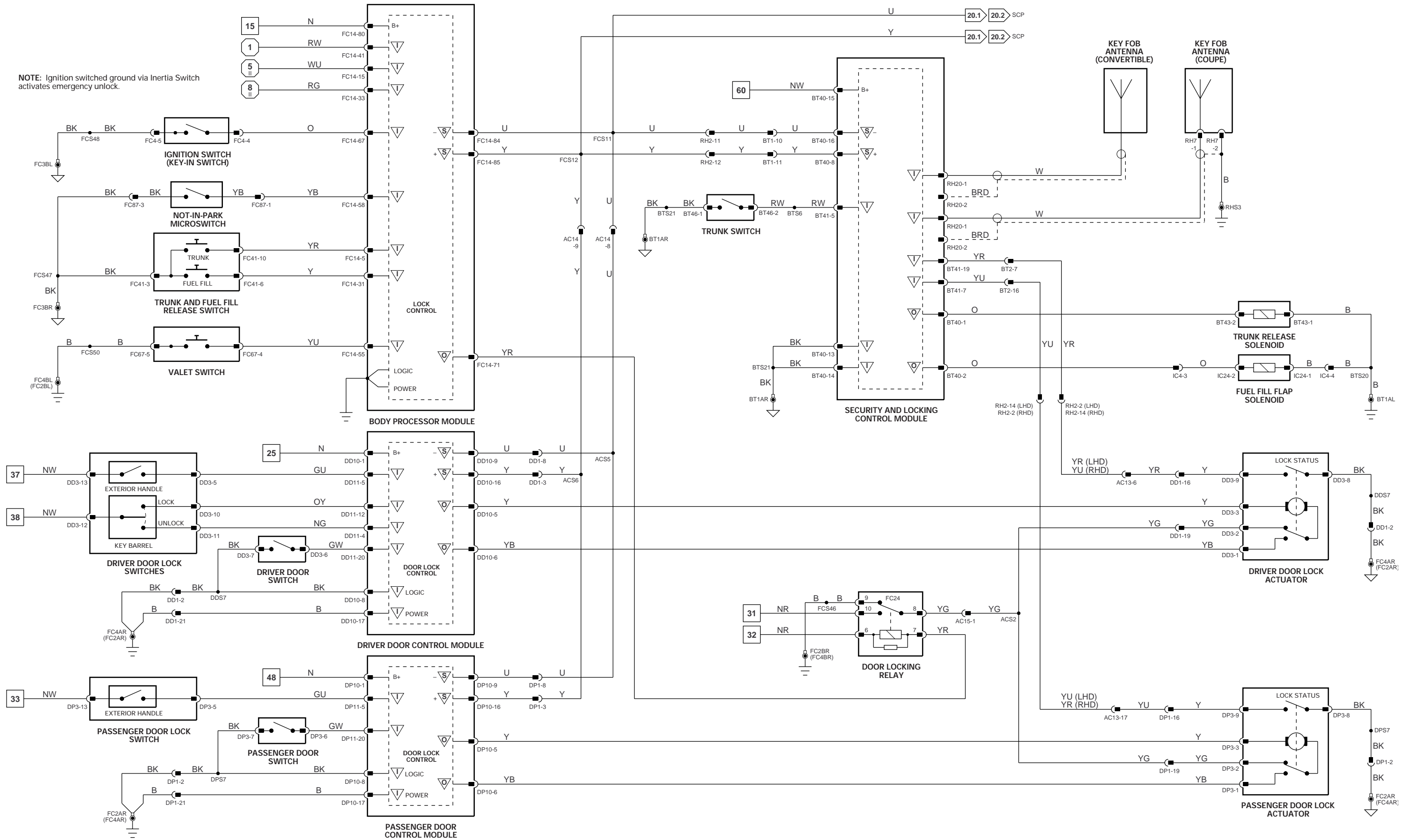

	<p>Fig. 01.1: 1 → 6, 1 → 5</p> <p>Fig. 01.2: 7 → 52, 53 → 92</p> <p>Fig. 01.3: 6 → 52, 53 → 67</p> <p>Fig. 01.4: 6 → 52</p> <p>Fig. 01.5: 53 → 67</p> <p>Fig. 02.1: 1 → 19</p>	<p>Legend:</p> <ul style="list-style-type: none"> <li>▽ Input</li> <li>▽ Signal Ground (SG)</li> <li>▽ CAN (Network)</li> <li>▽ Output</li> <li>▽ Serial and Encoded Communications</li> <li>▽ SCP Network</li> </ul>	<p>VARIANT: All Vehicles</p> <p>VIN RANGE: A00116 →</p> <p>DATE OF ISSUE: September 1999</p>
--	--	---	--



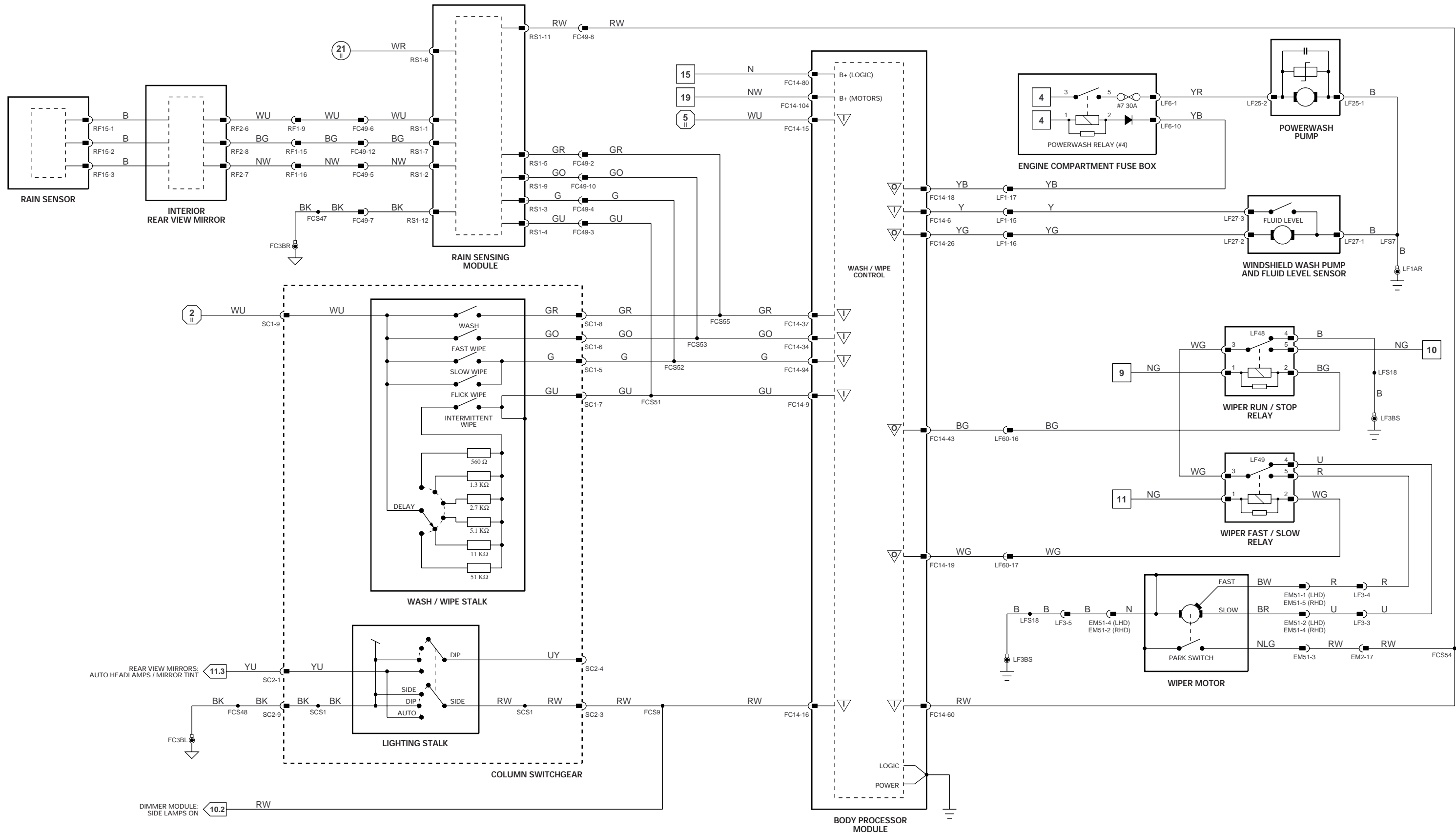

	<p>1 → 6 Fig. 01.1</p> <p>7 → 52 Fig. 01.2</p> <p>53 → 92 Fig. 01.3</p> <p>6 → 52 Fig. 01.4</p> <p>53 → 67 Fig. 01.5</p> <p>1 → 19 Fig. 02.1</p>	<p>▽ Input</p> <p>▽ Signal Ground (SG)</p> <p>▽ CAN (Network)</p> <p>▽ Serial and Encoded Communications</p> <p>▽ SCP Network</p>	<p>VARIENT: All Vehicles</p> <p>VIN RANGE: A00116 →</p> <p>DATE OF ISSUE: September 1999</p>
--	--	---	--



NOTE: BPM Convertible Top control - Convertible vehicles only.

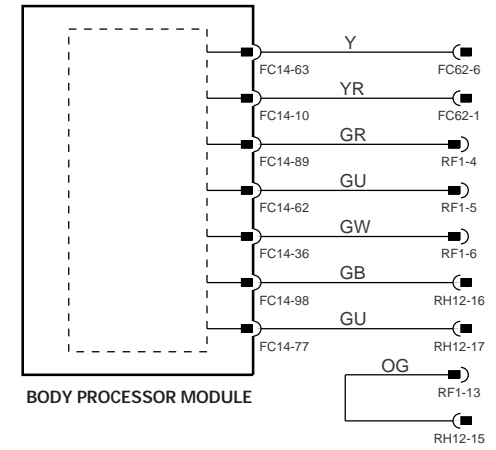
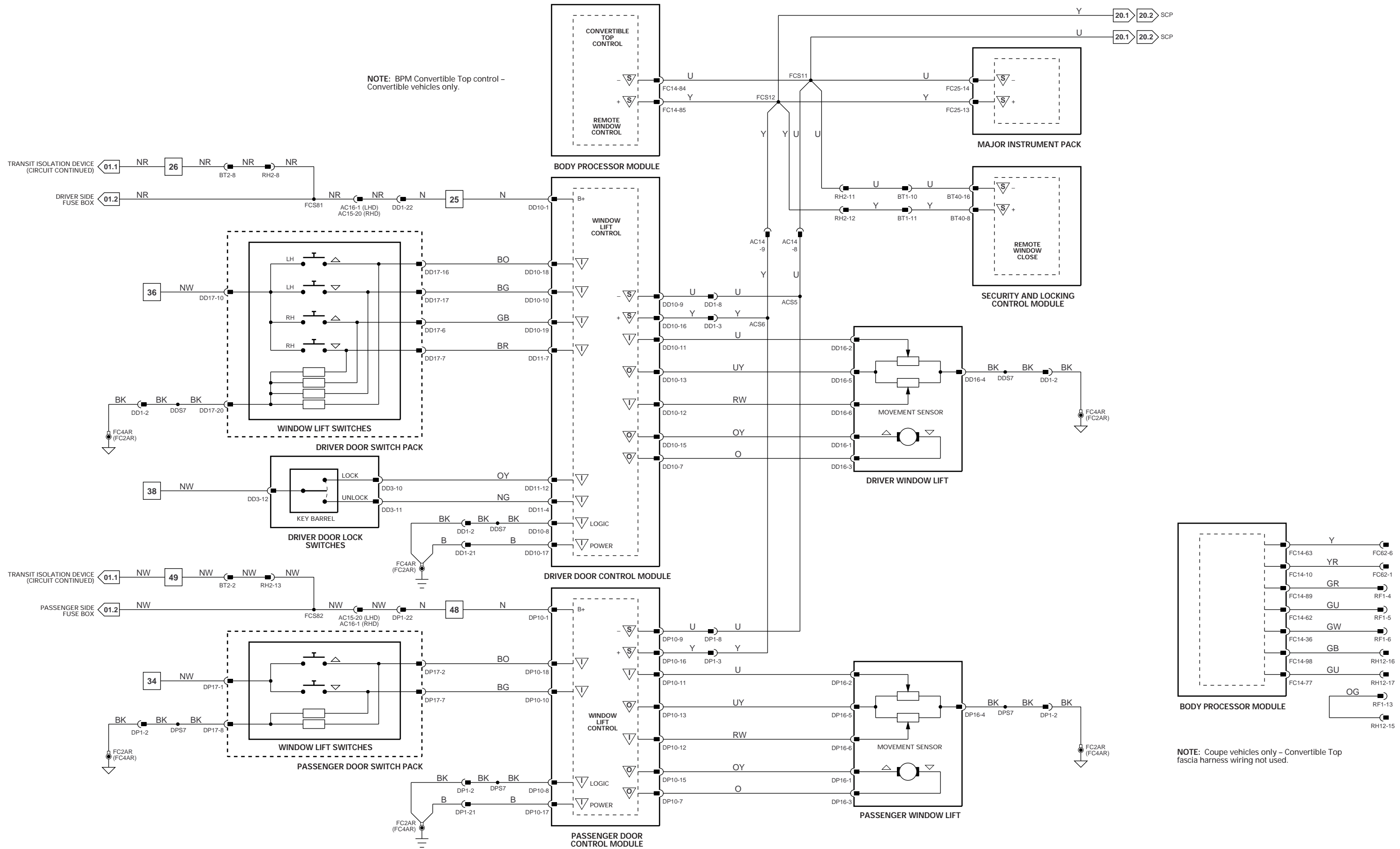

NOTE: Coupe vehicles only - Convertible Top fascia harness wiring not used.

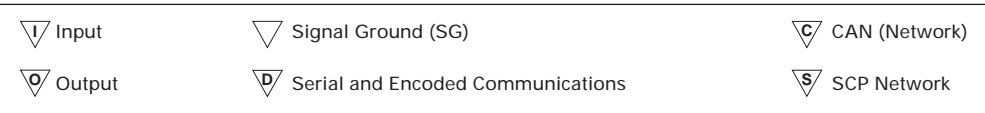
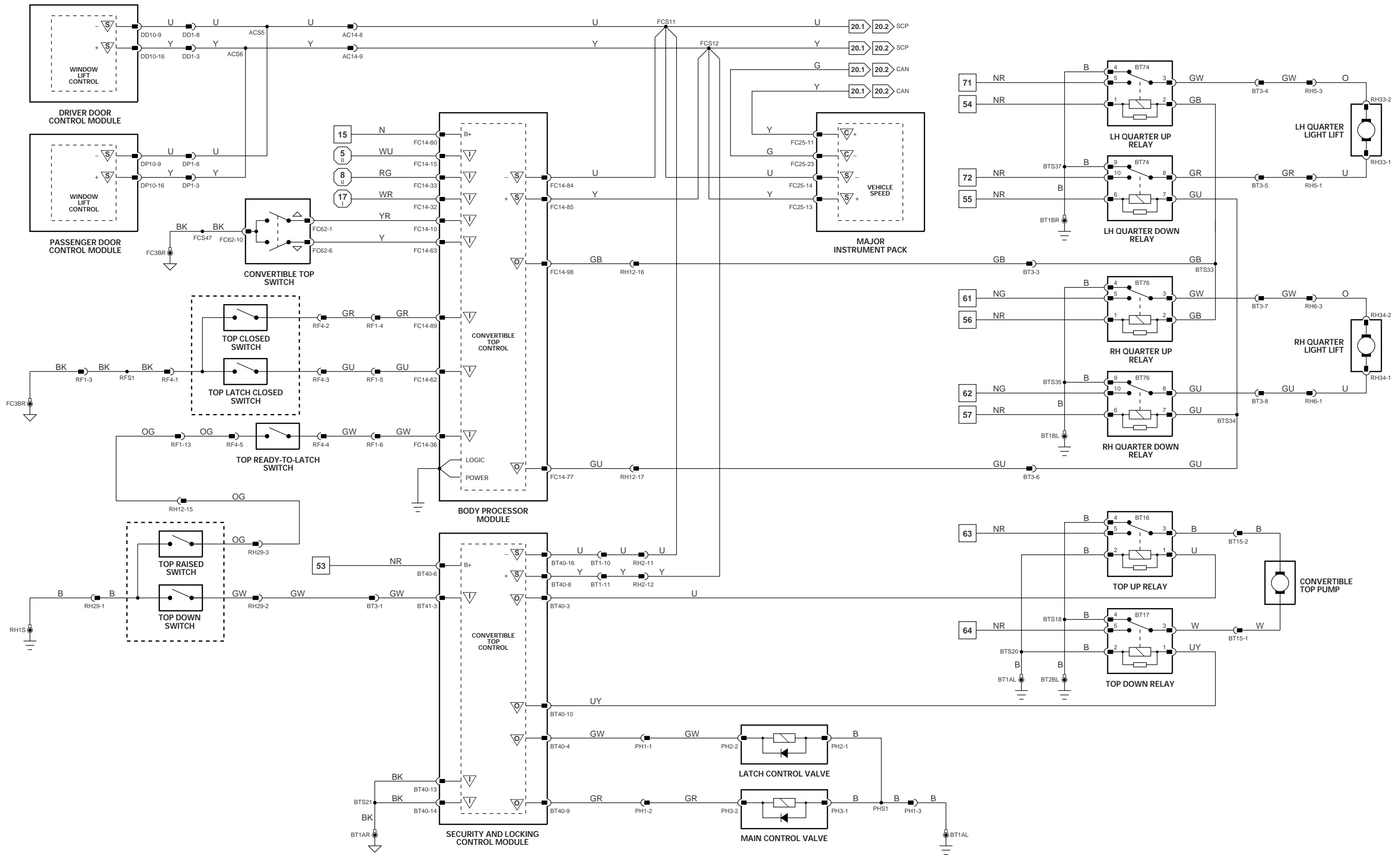

VARIANT: Convertible Vehicles  
 VIN RANGE: A00116 →  
 DATE OF ISSUE: September 1999

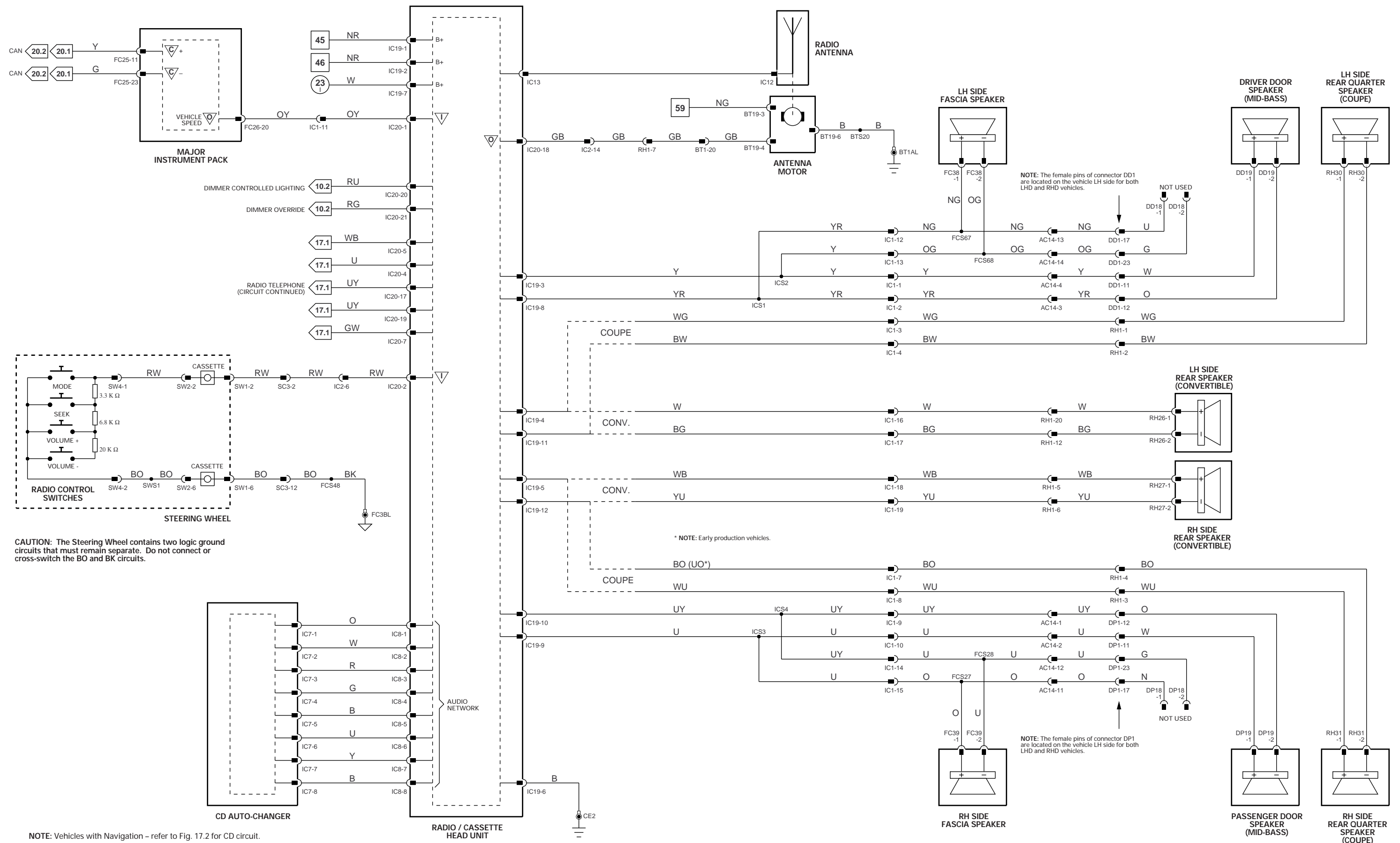

CAUTION: The Steering Wheel contains two logic ground circuits that must remain separate. Do not connect or cross-switch the BO and BK circuits.

NOTE: Vehicles with Navigation - refer to Fig. 17.2 for CD circuit.

	<p>1 → 6 Fig. 01.1</p> <p>7 → 52 Fig. 01.2</p> <p>53 → 92 Fig. 01.3</p> <p>6 → 52 Fig. 01.4</p> <p>53 → 67 Fig. 01.5</p> <p>1 → 19 Fig. 02.1</p>	<p>▽ Input</p> <p>▽ Output</p> <p>▽ Signal Ground (SG)</p> <p>▽ Serial and Encoded Communications</p> <p>▽ CAN (Network)</p> <p>▽ SCP Network</p>	<p>VARIANT: Standard ICE Vehicles</p> <p>VIN RANGE: A00116 →</p> <p>DATE OF ISSUE: September 1999</p>
--	--	---	---

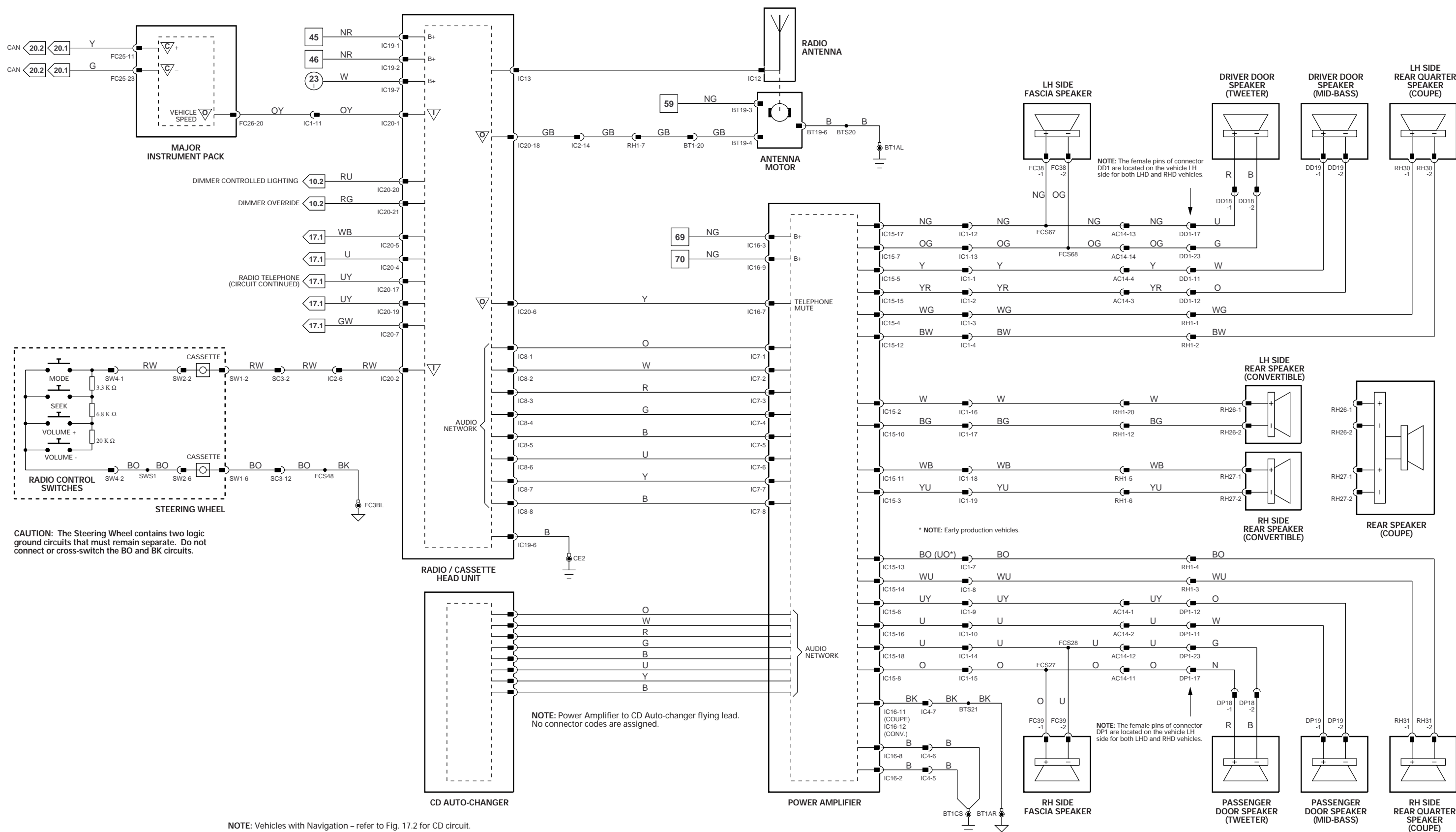

NOTE: Vehicles with Navigation - refer to Fig. 17.2 for CD circuit.

1 → 6 Fig. 01.1	7 → 52 Fig. 01.2	6 → 52 Fig. 01.4	1 → 19 Fig. 02.1	▽ Input	▽ Signal Ground (SG)	▽ CAN (Network)
1 → 5 Fig. 01.1	53 → 92 Fig. 01.3	53 → 67 Fig. 01.5		▽ Output	▽ Serial and Encoded Communications	▽ SCP Network

**VARIANT:** Premium ICE Vehicles  
**VIN RANGE:** A00116 →  
**DATE OF ISSUE:** September 1999

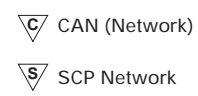
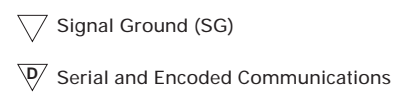
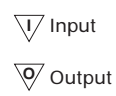
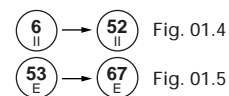
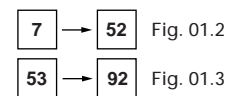
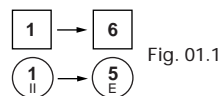
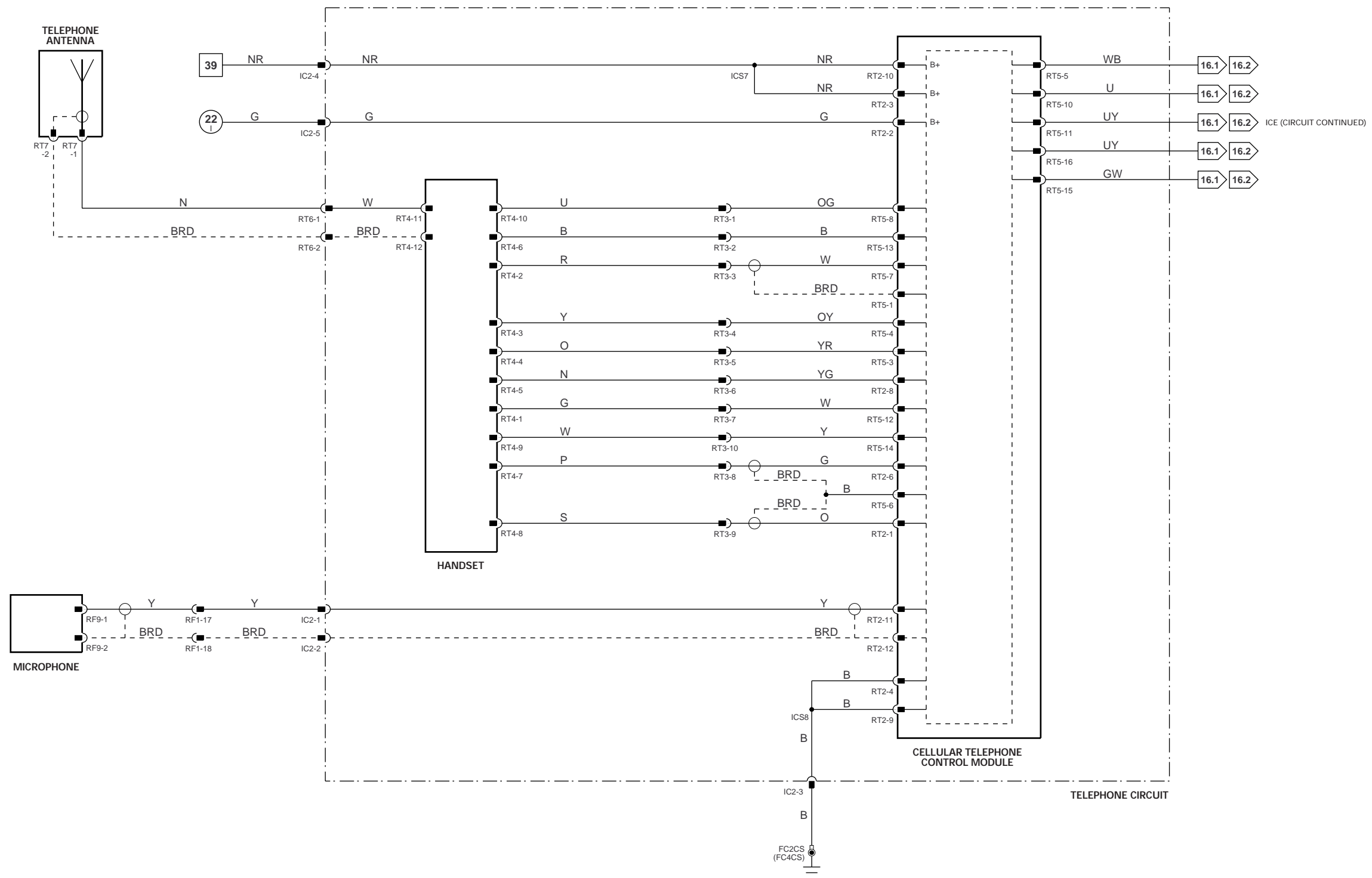

VARIANT: All Vehicles  
 VIN RANGE: A00116 →  
 DATE OF ISSUE: September 1999

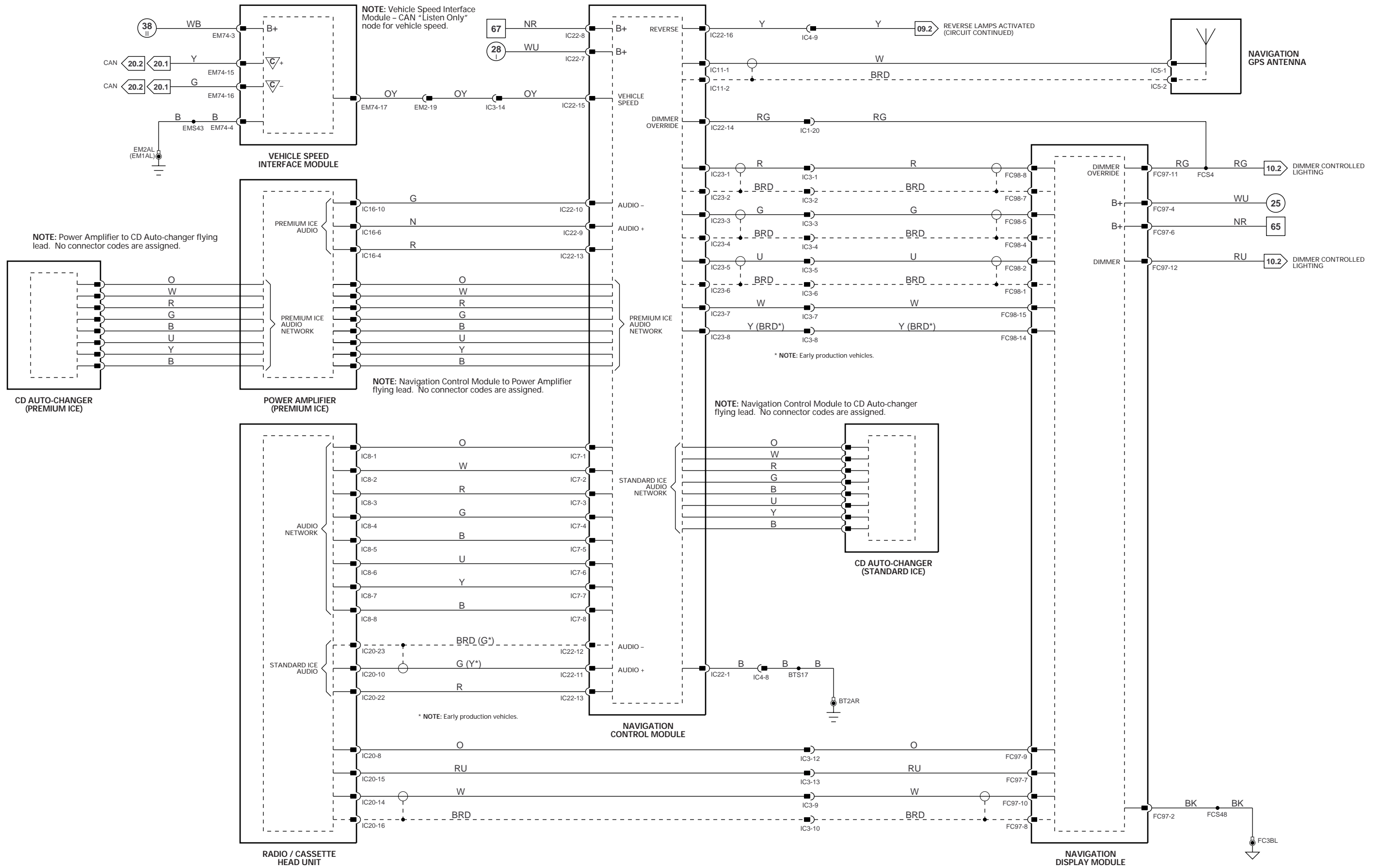

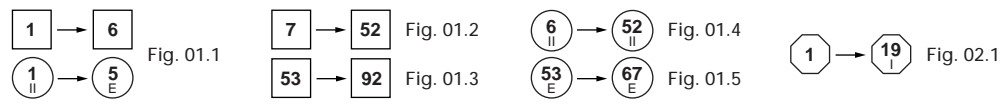
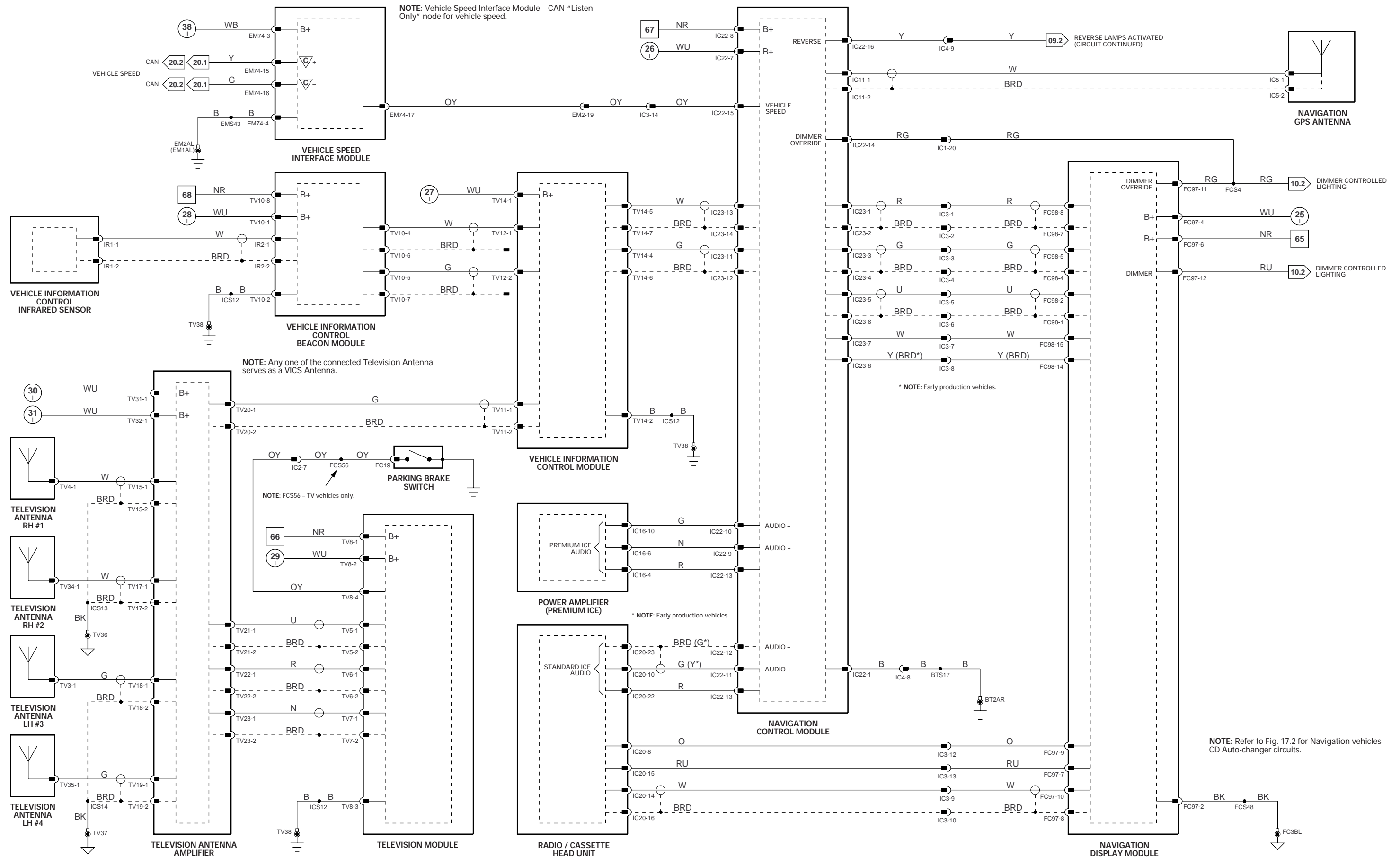

**VARIANT:** TV and VICS Vehicles  
**VIN RANGE:** A00116 →  
**DATE OF ISSUE:** September 1999



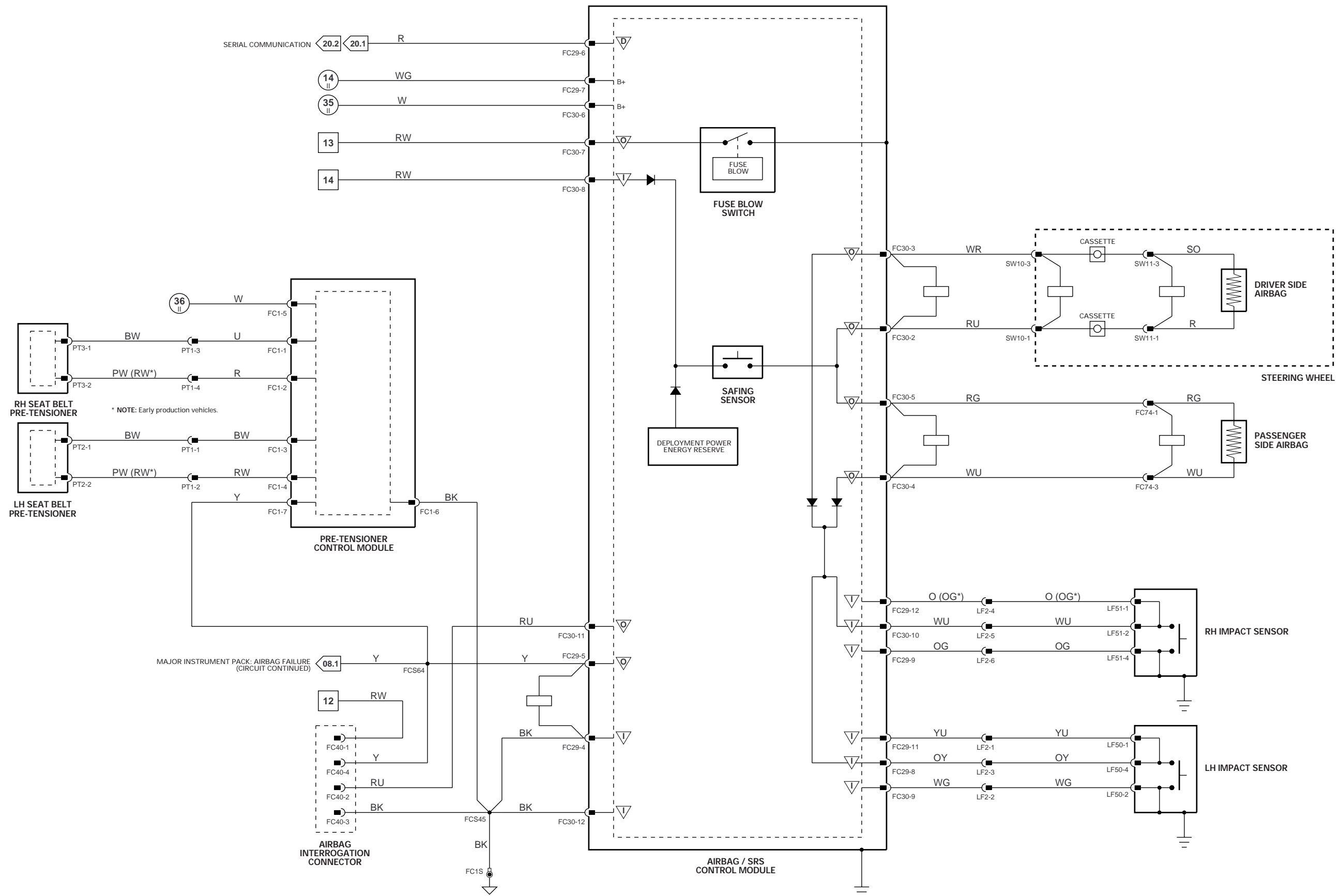

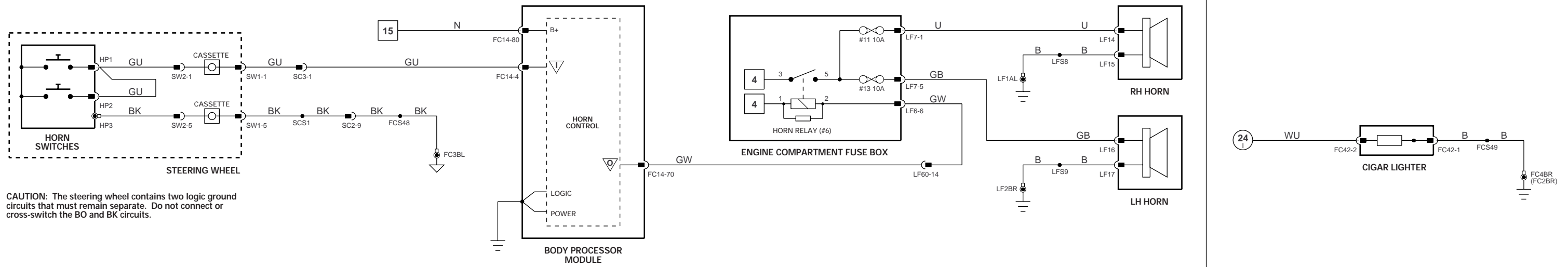

HORNS

CIGAR LIGHTER

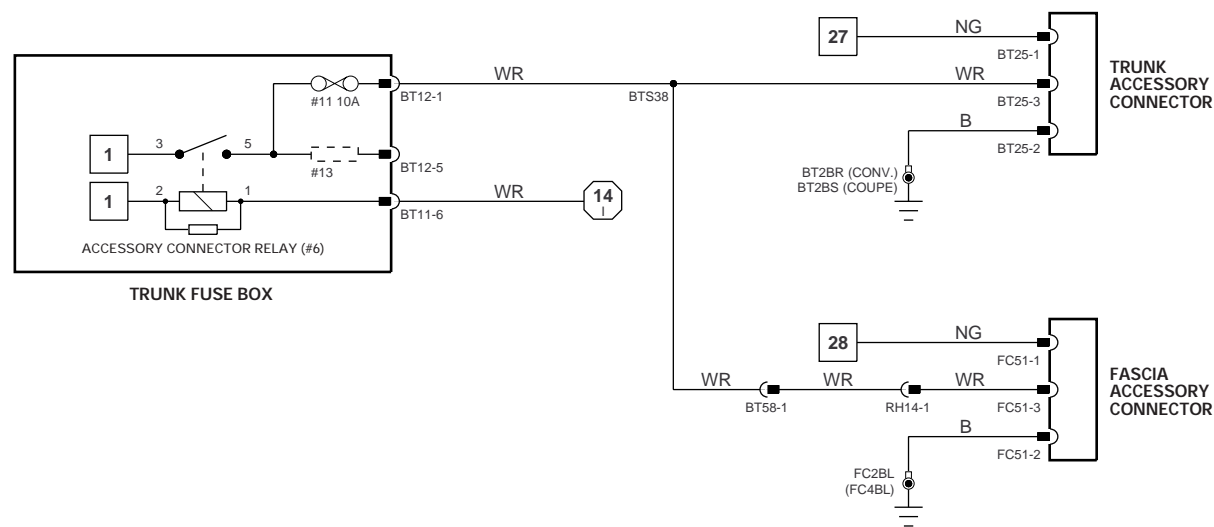

ACCESSORY CONNECTORS

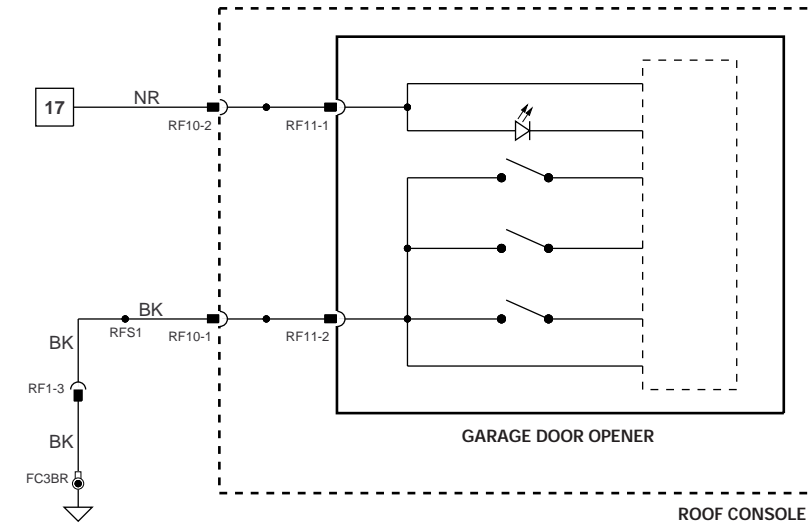

GARAGE DOOR OPENER

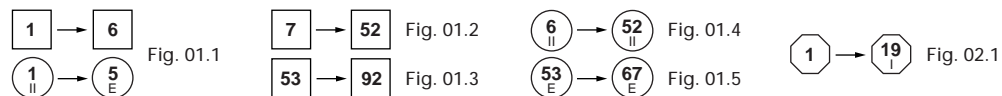

**VARIANT:** All Vehicles  
**VIN RANGE:** A00116 →  
**DATE OF ISSUE:** September 1999

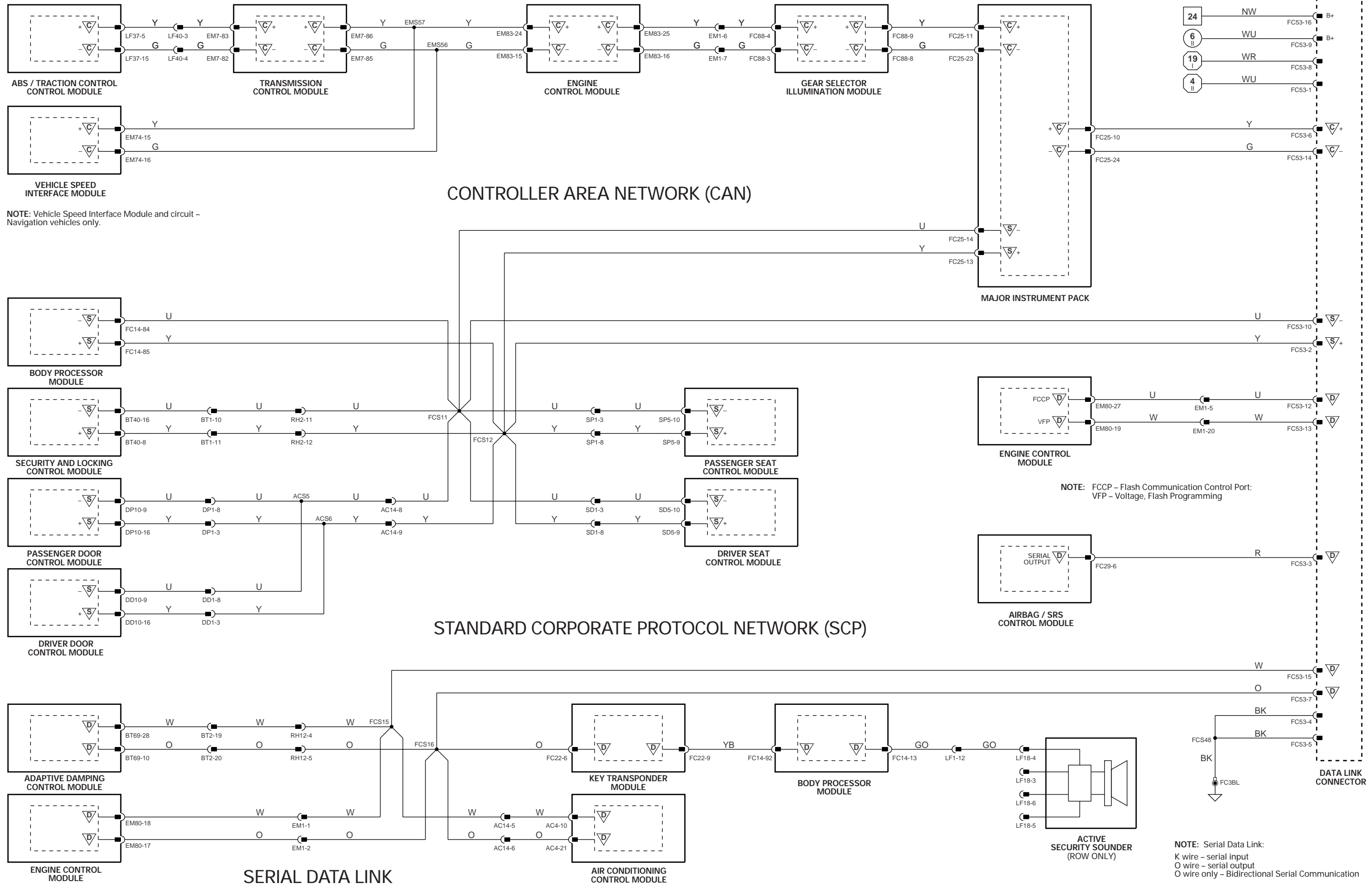

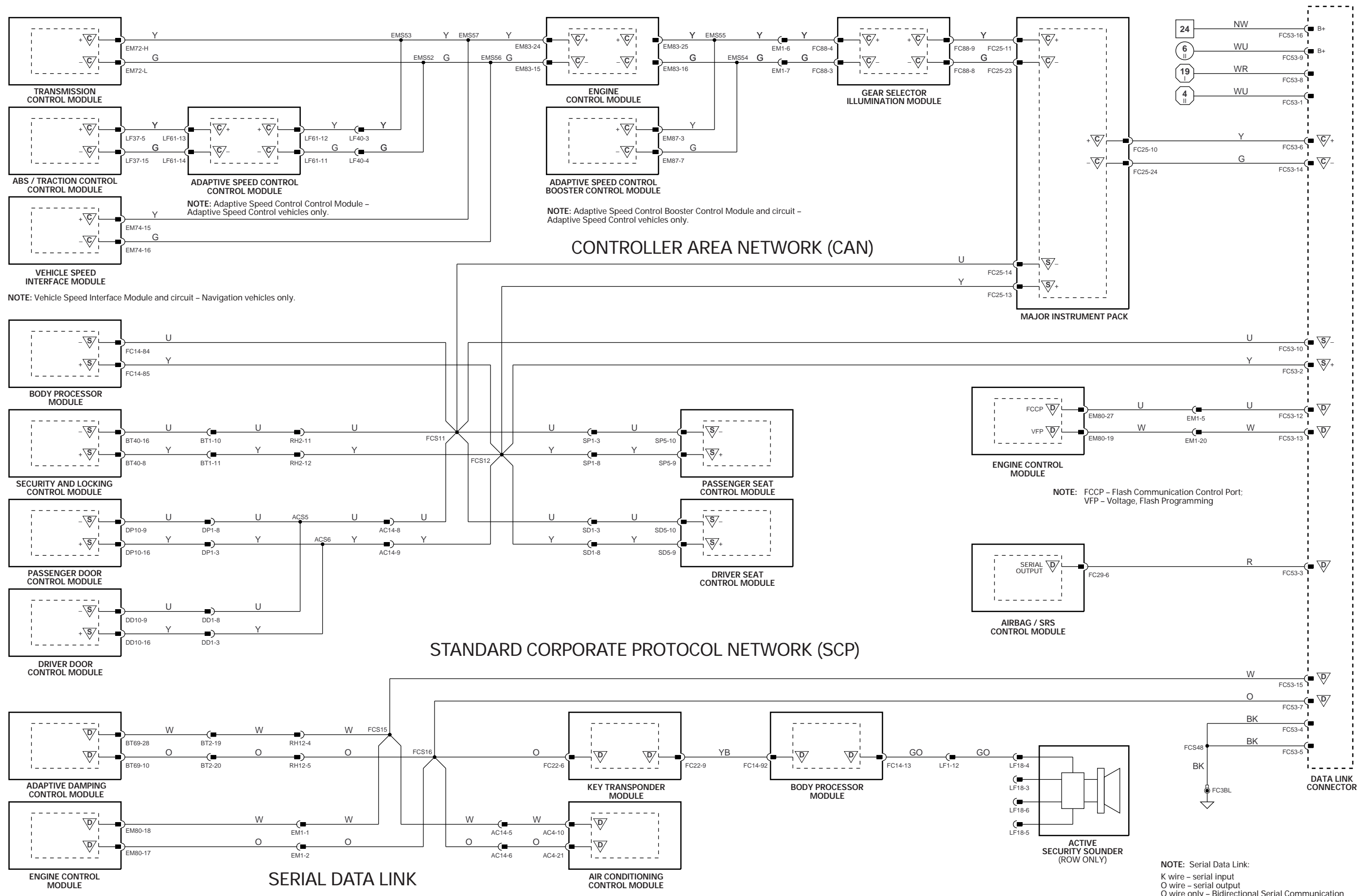

NOTE: Adaptive Speed Control Control Module - Adaptive Speed Control vehicles only.

NOTE: Adaptive Speed Control Booster Control Module and circuit - Adaptive Speed Control vehicles only.

NOTE: Vehicle Speed Interface Module and circuit - Navigation vehicles only.

NOTE: FCCP - Flash Communication Control Port; VFP - Voltage, Flash Programming

NOTE: Serial Data Link: K wire - serial input; O wire - serial output; O wire only - Bidirectional Serial Communication



VARIANT: AJ27 SC Vehicles  
VIN RANGE: A00116 →  
DATE OF ISSUE: September 1999



This Appendix contains a listing of CAN and SCP Network messages.

## Abbreviations

The following abbreviations are used throughout this Appendix:

ABS/TCCM	Anti-Lock Braking / Traction Control Control Module
BPM	Body Processor Module
DIAG	Diagnostics
DDCM	Driver Door Control Module
DSCM	Driver Seat Control Module
ECM	Engine Control Module
INST	Instrument Pack
J-GATE	Gear Selector Illumination Module
PDCM	Passenger Door Control Module
PSCM	Passenger Seat Control Module
R	Receive
T	Transmit
TCM	Transmission Control Module
SCCM	Adaptive Speed Control Control Module
SCBCM	Adaptive Speed Control Booster Control Module
SLCM	Security and Locking Control Module



## CAN Message Matrix

Message / Function	Source	Receivers								
		ECM	TCM	ABS/TCCM	INST	J-GATE	SCCM	SCBCM	DIAG	
CAN traction acknowledge	ECM		X							
CAN traction control estimated engine torque	ECM		X							
CAN set speed	ECM						X			
CAN target speed	ECM						X			
CAN shift energy management estimated engine torque	ECM		X	X						
CAN throttle position	ECM		X	X						
CAN pedal position	ECM		X	X			X			
CAN torque reduction acknowledge	ECM		X							
CAN engine speed	ECM		X	X	X					
CAN brake pedal pressed	ECM			X	X		X	X		
CAN ECM adaptive speed control fail	ECM						X			
CAN speed control status	ECM		X				X			
CAN parking brake status	ECM				X					
CAN OBD II clear fault codes	ECM		X	X						
CAN headway increment	ECM						X			
CAN cancel request	ECM						X			
CAN engine coolant temperature	ECM		X		X					
CAN engine OBD II MIL	ECM			X	X					
CAN throttle malfunction red	ECM			X	X					
CAN throttle malfunction amber	ECM			X	X					
CAN ECM fault code MIL status	ECM			X						
CAN ECM PECUS flag	ECM				X					
CAN engine fault codes	ECM			X						
CAN fuel used	ECM				X					
CAN barometric pressure	ECM		X							
CAN torque reduction request	TCM	X								
CAN transmission overload	TCM	X								
CAN transmission input speed	TCM	X		X						
CAN transmission output speed	TCM	X		X						
CAN torque converter slip	TCM	X		X						
CAN kickdown	TCM	X		X						



Message / Function	Source	Receivers							
		ECM	TCM	ABS/TCCM	INST	J-GATE	SCCM	SCBCM	DIAG
CAN gear position actual	TCM	X		X					
CAN torque converter status	TCM	X		X					
CAN gear position selected	TCM	X			X	X			
CAN gear selection fault	TCM	X			X	X			
CAN transmission shift map	TCM	X		X			X		
CAN transmission oil temperature	TCM	X			X				
CAN transmission malfunction	TCM	X		X	X				
CAN TCM PECUS flag	TCM				X				
CAN gear position target (not used)	TCM			X					
CAN torque transfer in progress (not used)	TCM			X					
CAN TCM fault code MIL status	TCM	X							
CAN OBD II TCM clear acknowledge	TCM	X							
CAN transmission fault codes	TCM	X		X					
CAN torque reduction throttle	ABS/TCCM	X							
CAN fast torque reduction ignition	ABS/TCCM	X							
CAN fast torque reduction cylinder	ABS/TCCM	X							
CAN traction status	ABS/TCCM	X			X				
CAN traction shift map	ABS/TCCM		X						
CAN ABS PECUS flag	ABS/TCCM				X				
CAN vehicle reference speed	ABS/TCCM	X			X				
CAN reference distance traveled	ABS/TCCM				X				
CAN ABS fault codes	ABS/TCCM	X							
CAN OBD II ABS clear acknowledge	ABS/TCCM	X							
CAN ABS fault code MIL status	ABS/TCCM	X							
CAN ABS malfunction	ABS/TCCM	X			X			X	
CAN ABS status	ABS/TCCM							X	
CAN front left wheel speed	ABS/TCCM	X	X				X	X	
CAN front right wheel speed	ABS/TCCM	X	X				X	X	
CAN rear left wheel speed	ABS/TCCM	X	X				X		
CAN rear right wheel speed	ABS/TCCM	X	X		X		X		
CAN sidelight status	INST	X							



## CAN Message Matrix

Message / Function	Source	Receivers							
		ECM	TCM	ABS/TCCM	INST	J-GATE	SCCM	SCBCM	DIAG
CAN dipped beam status	INST	X							
CAN main beam status	INST	X							
CAN oil pressure low	INST	X							
CAN indicator right	INST						X		
CAN indicator left	INST						X		
CAN trip units	INST	X					X		
CAN fuel level damped	INST	X							
CAN fuel level raw	INST	X							
CAN display commands	SCCM				X				
CAN headway setting	SCCM				X				
CAN follow warning light	SCCM				X				
CAN extra bong	SCCM				X				
CAN display set speed	SCCM				X				
CAN follow speed	SCCM	X							
CAN brake demand pressure	SCCM							X	
CAN adaptive speed control status	SCCM				X				
CAN adaptive speed control PECUS flag	SCCM				X				
CAN brake booster enable	SCCM							X	
CAN brake actual pressure	SCBCM						X		
CAN brake demand pressure acknowledge	SCBCM						X		
CAN SBU status	SCBCM						X		
CAN diagnostic data in acknowledge	DIAG						X		
CAN diagnostic data out acknowledge	SCCM								X
CAN diagnostic data in SCBCM	DIAG							X	
CAN diagnostic data out SCBCM	SCBCM								X
CAN NWM token ECM	ECM		X	X	X		X		
CAN NWM token TCM	TCM	X		X	X		X		
CAN NWM token INST	INST	X	X	X			X		
CAN NWM token ABS	ABS/TCCM	X	X		X		X		
CAN NWM token SCCM	SCCM				X				
CAN diagnostic data in ECM	DIAG	X							





Message / Function	Source	Receivers							
		ECM	TCM	ABS/TCCM	INST	J-GATE	SCCM	SCBCM	DIAG
CAN diagnostic data in TCM	DIAG		X						
CAN diagnostic data in INST	DIAG				X				
CAN diagnostic data in ABS	DIAG			X					
CAN diagnostic data out ECM	ECM								X
CAN diagnostic data out TCM	TCM								X
CAN diagnostic data out INST	INST								X
CAN diagnostic data out ABS	ABS/TCCM								X



SCP Message Matrix

#	Message Name	INST	BPM	DDCM	PDCM	DSCM	PSCM	SLCM
1	Vehicle speed	T	R	R				R
2	Brake pedal pressed	T	R					
3	SLCM not programmed	R						T
4	BPM not programmed	R	T					
5	DDCM not programmed	R		T				
6	DSCM not programmed	R				T		
7	PDCM not programmed	R			T			
8	PSCM not programmed	R					T	
9	Left hand drive vehicle		T	R	R			R
10	Valet mode OFF		T					R
11	Non-convertible vehicle		T					R
12	Right hand drive vehicle		T	R	R			R
13	Valet mode ON		T					R
14	Convertible vehicle		T					R
15	Request vehicle drive side		R	T				
16	Request valet mode status		R					T
17	Request convertible status		R					T
18	Reverse gear selected	T	R	R	R	R	R	R
19	Not-in-park switch – inactive		T	R	R	R	R	
20	Not-in-park switch – active		T	R	R	R	R	
21	Request not-in-park switch status		R			T		
22	Request not-in-park switch status		R				T	
23–58	Diagnostic messages							
59	Charging OK	T				R	R	
60	Inertia switch inactive		T	R	R			R
61	Inertia switch active		T	R	R			R
62	Request inertia switch status		R	T				
63	Request inertia switch status		R		T			
64	Ignition status	R	T	R	R	R	R	R
65	Key not-in-ignition		T	R	R			R
66	Key in-ignition		T	R	R			R
67	Request ignition status		R					T
68	Request ignition status	T	R					
69	Request ignition status		R	T				
70	Request ignition status		R			T		
71	Request ignition status		R		T			
72	Request ignition status		R				T	
73	Request key-in status		R					T
74	Request key-in status		R	T				
75	Request key-in status		R			T		
76	Request key-in status		R		T			
77	Seat belt telltale OFF	R				T		
78	Low washer fluid warning OFF	R	T					
79	Convertible top latch warning OFF	R						T
80	Seat belt telltale ON	R				T		
81	Low washer fluid warning ON	R	T					
82	Convertible top latch warning ON	R						T
83	Request washer fluid status	T	R					
84	Request convertible top latch status	T						R
85	Security audible indication		R					T
86	Remote panic		R	R	R			T
87	Security disarm		R	R	R			T
88	Glass break fault		T					R
89	Security armed		R	R	R			T
90	Key valid		T					R
91	Glass break detected		T					R
92	Request security arm status		T					R
93	Request security arm status		T					R



#	Message Name	INST	BPM	DDCM	PDCM	DSCM	PSCM	SLCM
94	Request security arm status				T			R
95	Seat belt chime OFF		R			T		
96	Seat belt chime ON		R			T		
97	Request seat belt chime status		T			R		
98-165	Diagnostic messages							
166	Recall memory 1		R	T	R	R		
167	Recall memory 2		R	T	R	R		
168	Save memory 1		R	T	R	R		
169	Save memory 2		R	T	R	R		
170	DDCM memory 1 recalled		R	T				
171	DSCM memory 1 recalled		R			T		
172	PDCM memory 1 recalled		R		T			
173	DDCM memory 2 recalled		R	T				
174	DSCM memory 2 recalled		R			T		
175	PDCM memory 2 recalled		R		T			
176	Park fold-back mirrors			T		R	R	
177	Unfold fold-back mirrors			T		R	R	
178	Stop driver mirror			T	R			
179	Stop passenger mirror			T	R			
180	Driver mirror up			T	R			
181	Passenger mirror up			T	R			
182	Driver mirror down			T	R			
183	Passenger mirror down			T	R			
184	Passenger mirror right			T	R			
185	Passenger mirror left			T	R			
186	Unlock driver door			R	T			
187	Unlock passenger door			T	R			
188	Remote unlock	R	R	R				T
189	Remote trunk release	R						T
190	Lock front doors	R	T					
191	Lock front doors	R			T			
192	Remote superlock			R	R			T
193	Superlock driver door					T		
194	Superlock passenger door			T				
195	Remote lock	R						T
196	Vehicle unlocked	R	T					R
197	Driver door unlocked	R	R	R				T
198	Passenger door unlocked	R		R				T
199	Driver lock switch status	R	T					R
200	Passenger lock switch status	R		T				R
201	Driver door unsuperlocked	R	T					
202	Passenger door unsuperlocked	R		T				
203	Vehicle locked	R	T					R
204	Driver door locked	R	R	R				T
205	Passenger door locked	R	R	R				T
206	Driver door superlocked	R	T					
207	Passenger door superlocked	R		T				
208	Request vehicle lock status		R					T
209	Request driver door lock status		T					R
210	Request passenger door status			T				R
211	Request driver key barrel status		R					T
212	Request driver key barrel status		R	T				
213	Request passenger key barrel status (deleted)			R				T
214	Request passenger key barrel status (deleted)			T	R			
215	Request superlock status	T	R	R				
216	Open trunk	T						R

continued...



## SCP Message Matrix

#	Message Name	INST	BPM	DDCM	PDCM	DSCM	PSCM	SLCM
217	Hood closed	R	T					R
218	Driver door closed	R	R	T		R		R
219	Passenger door closed	R	R			T	R	R
220	Trunk closed	R	R					T
221	Stop fuel filler flap open		T					R
222	Convertible top latch status		T					
223	Hood ajar	R	T					R
224	Driver door ajar	R	R	T		R		R
225	Passenger door ajar	R	R		T		R	R
226	Trunk ajar	R	R					T
227	Open fuel filler flap		T					R
228	Request hood ajar status		R					T
229	Request driver door ajar status			R				T
230	Request driver door status		T	R				
231	Request driver door ajar status			R		T		
232	Request passenger door ajar status				R			T
233	Request trunk ajar status		T					R
234	Request convertible top latch switches status		R					T
235	Driver seat heater telltale OFF		R			T		
236	Passenger seat heater telltale OFF		R				T	
237	Driver seat heater telltale ON		R			T		
238	Passenger seat heater telltale ON		R				T	
239	Request driver heater telltale status		T			R		
240	Request passenger heater telltale status		T				R	
241	Stop global window open		R	R	R			T
242	Stop global window close		R	R	R			T
243	Position driver window			R				T
244	Position passenger window				R			T
245	Position rear quarters		R					T
246	Driver window position			T				R
247	Passenger window position				T			R
248	Stop passenger window open			T	R			
249	Stop convertible top open		T					R
250	Stop passenger window close			T	R			
251	Stop convertible top close		T					R
252	Open passenger window			T	R			
253	Open convertible top		T					R
254	Close passenger window			T	R			
255	Close convertible top		T					R
256	Request driver window position			R				T
257	Request passenger window position				R			T
258	Request driver and passenger window switch status			R	T			
259	Driver seat heater switch active		T			R		
260	Passenger seat heater switch active		T				R	
261	Front bulb failure	R	T					
262	Rear bulb failure	R						T
263	Front bulbs OK	R	T					
264	Rear bulbs OK	R						T
265	Request front bulb fail status	T	R					
266	Request rear bulb fail status	T						R
267	Rear fog lamps OFF		T					R
268	Remote headlamp convenience OFF		R					T
269	Rear fog lamps ON		T					R
270	Remote headlamp convenience ON		R					T
271	Dip beam OFF	R	T					
272	Side lamps OFF	R	T					
273	Hazard warning OFF	R	T					
274	Left DI lamp OFF	R	T					



#	Message Name	INST	BPM	DDCM	PDCM	DSCM	PSCM	SLCM
275	Right DI lamp OFF	R	T					
276	Main beam OFF	R	T					
277	Rear fog lamps OFF		R					T
278	Main beam flash OFF		T					R
279	Request rear fog switch status		R					T
280	Request remote headlamp convenience status		T					R
281	Dip beam ON	R	T					
282	Side lamps ON	R	T					
283	Hazards ON	R	T					
284	Left DI lamp ON	R	T					
285	Right DI lamp ON	R	T					
286	Main beam ON	R	T					
287	Rear fog lamps ON		R					T
288	Main beam flash ON		T					R
289	Request dip beam status	T	R					
290	Request side lamps status	T	R					
291	Request left DI status	T	R					
292	Request right DI status	T	R					
293	Request main beam status	T	R					
294	Request hazard warning status	T	R					
295	Request rear fog lamps status		T					R
296	Interior lamps OFF	R	T					
297	Interior lamps ON	R	T					
298	Request interior lighting status	T	R					
299	Valet mode message OFF	R	T					
300	Recoding keying message OFF	R						T
301	Valet mode message	R	T					
302	Recoding keying message	R						T
303–356	Diagnostic messages							
357	Wake up (SLCM)							T
358	Wake up (BPM)		T					
359	Wake up (INST)	T						
360	Wake up (DDCM)			T				
361	Wake up (DSCM)					T		
362	Wake up (PDCM)				T			
363	Wake up (PSCM)						T	
364	Network awake (SLCM)	R	R	R	R	R	R	T
365	Network awake (BPM)	R	T	R	R	R	R	R
366	Network awake (INST)	T	R	R	R	R	R	R
367	Network awake (DDCM)	R	R	T	R	R	R	R
368	Network awake (DSCM)	R	R	R	R	T	R	R
369	Network awake (PDCM)	R	R	R	T	R	R	R
370	Network awake (PSCM)	R	R	R	R	R	T	R
371	SLCM entering sleep mode	R	R	R	R	R	R	T
372	BPM entering sleep mode	R	T	R	R	R	R	R
373	INST entering sleep mode	T	R	R	R	R	R	R
374	DDCM entering sleep mode	R	R	T	R	R	R	R
375	DSCM entering sleep mode	R	R	R	R	T	R	R
376	PDCM entering sleep mode	R	R	R	T	R	R	R
377	PSCM entering sleep mode	R	R	R	R	R	T	R

